MiTek[®]

SERVICE BULLETIN

Document ID:

SB287

Title:

LASM Auto-Homing Update

Affected machinery: BLADE II™ Saw

Distribution: All customers with affected machinery

Sensitivity: Approved for Customer Use

CAUTION:

MiTek recommends printing this document in high resolution using color ink. Many of the graphics may be unclear and may create an unsafe condition if this recommendation is not followed.

MiTek Automation
Phone: 800-523-3380
Fax: 636-328-9218
www.mitek-us.com

Part # and Rev.	SB287
Print Date	27 February 2025
Effectivity	Frames 488-present
Revision Date	
Revised By	
Rev. Approved By	
Orig. Release Date	21 February 2025
Orig. Created By	A. McIntire
Orig. Approved By	R. Tucker

Purpose and Scope

This service bulletin for the *BLADE II* saw instructs how to update the wiring that runs from the LASM lockout sensor to the PMM module to enable the LASM auto-homing process. Read the below notice before proceeding.

NOTICE

The saw PLC (Programmable Logic Controller) must be updated to version 10.005.002 before starting this update!

Go to **Diagnostics > Detailed Diagnostics > PLC** and check the **Version** field to determine the PLC version number.

If your PLC needs to be updated, please contact MiTek Automation Support at 1-800-523-3380.

Overview

Parts Included

The parts included in this kit are shown in [Table 1](#). Please make sure all parts and supplies are present before starting the procedure.

Table 1: Parts in SB287KIT

Quantity	Description	Part #
1	T-Coupler	509964
1	Signal cable	509965
1	Grommet	511860
1	Service bulletin document	SB287

If you have any questions, call MiTek Automation Support at 1-800-523-3380.

Supplies Needed





- Flathead or terminal block screwdriver
- Hex key set
- Wire cutter/stripper

Lockout/Tagout Instructions

Electrical Lockout/Tagout Procedure

The lockout/tagout instructions for the electrical systems will be referenced as necessary in this document. Service Bulletin instructions start on [page 4](#).

	 WARNING
	<p>ELECTROCUTION HAZARD.</p> <p>All electrical work must be performed by a qualified electrician.</p> <p>Verify that all power to the machine has been turned off and follow approved lockout/tagout safety procedures before performing any maintenance.</p> <p>If it is absolutely necessary to troubleshoot an energized machine, follow NFPA 70E for proper procedures and personal protective equipment.</p>

Procedure for Working Either on a Machine Inside the Machine's Main Electrical Enclosure or in the Electrical Transmission Line to the Machine.

1. If applicable, close machine software and shut down the PC using the **Power > Shut down** method in Windows.
2. Engage an E-stop on the machine.
3. Turn the machine's disconnect switch to the Off position. This is usually required to open the main electrical enclosure's door.
4. Shut the power to the machine off at the machine's power source, which is usually an electrical service entry panel on the facility wall. One example of a locked-out power source panel is shown in [Figure 1](#).
5. Attach a lock and tag that meet OSHA requirements for lockout/tagout to the electrical service entry panel.
6. Open the door to the enclosure to which you need access. Using a multimeter, verify that the power is off.





Figure 1: Lockout/Tagout on the Power Source Panel



Pneumatic or Hydraulic System Lockout/Tagout Procedure

The lockout/tagout instructions for the pneumatic or hydraulic systems will be referenced as necessary in this service bulletin.

	 WARNING
	<p>HIGH PRESSURE HAZARD.</p> <p>Bleed pneumatic lines before performing any maintenance on the system.</p> <p>Working on pressurized lines may cause injury.</p>

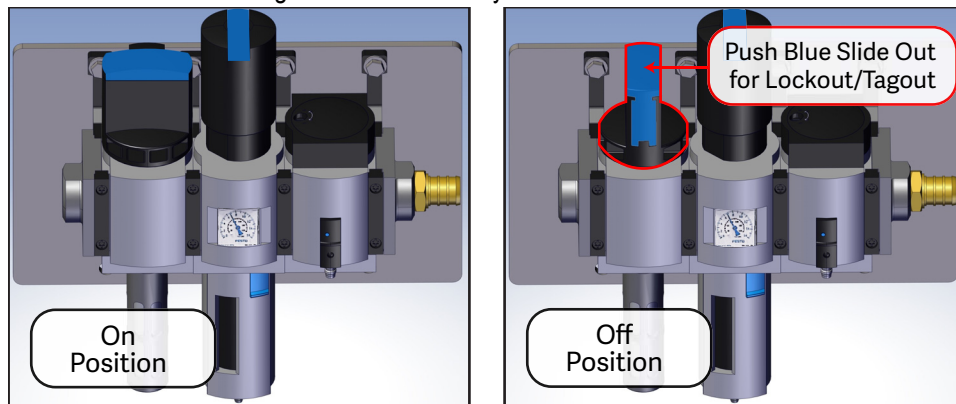

1. After lockout/tagout of the electrical power, turn off or close the system's air shut-off valve and attach a lock and tag. See [Figure 2](#).

Figure 2: Pneumatic System Shut-Off Valve



Procedure

Rewiring the PMM Module

	 WARNING
	<p>MOVING PARTS CAN CRUSH AND CUT.</p> <p>Always verify that power to the machine has been turned off and follow approved lockout/tagout procedures.</p>



1. Verify your saw PLC is at version 10.005.002 or later. See [Purpose and Scope on page 2](#) for further instructions.
2. Open the stroke / elevation door on the infeed and outfeed ends of the saw.
3. Lockout/tagout the electrical and pneumatic systems of the machine using the [Lockout/Tagout Instructions on page 3](#).

4. With power locked out as previously described, open the maintenance door shown in [Figure 3](#).

Figure 3: Outfeed Maintenance Door

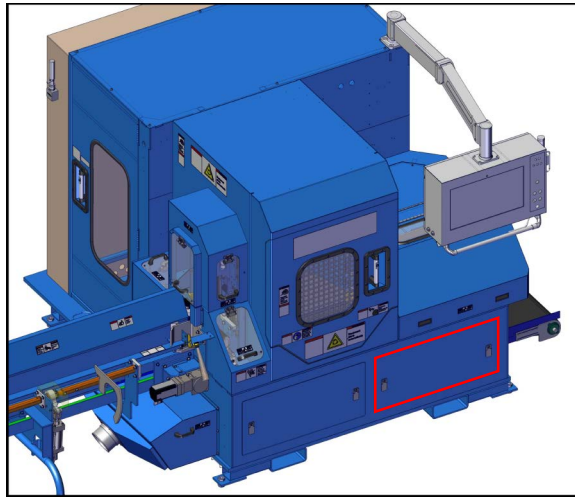

5. Remove the cable labeled PRS_21 from port 5 on the LASM assembly input module (see [Figure 4](#)).

Figure 4: LASM Assembly Input Module And T-Coupler

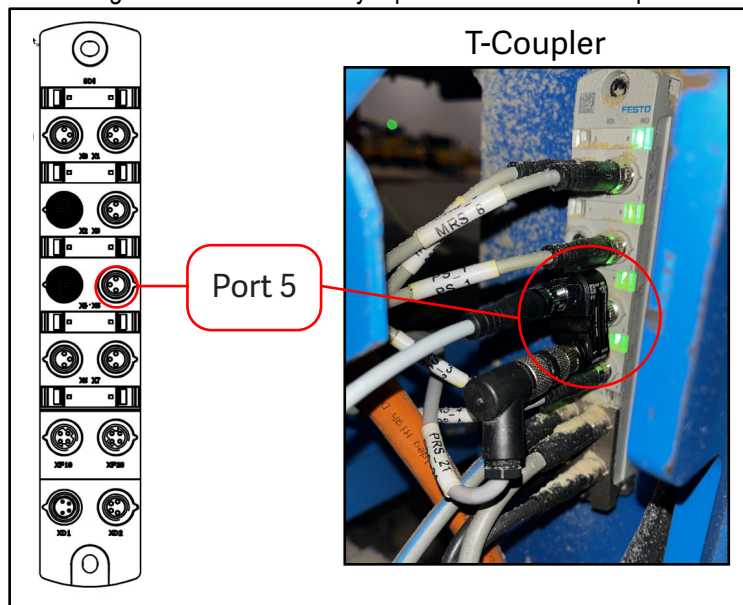

6. Connect (finger-tight) the T-coupler to port 5 on the LASM assembly input module (see [Figure 4](#)).
7. Connect (finger-tight) PRS_21 to one of the ports on the T-coupler and connect the new signal cable to the other port on the coupler.
8. Run the loose end of the signal cable through opening in the base plate near the input module (see [Figure 5](#)).

- Run the cable through the wire runner (under the saw) to the stroke / elevation chamber. Be careful to not pinch or sharply bend the signal cable.

Figure 5: Wire Routing Under Saw

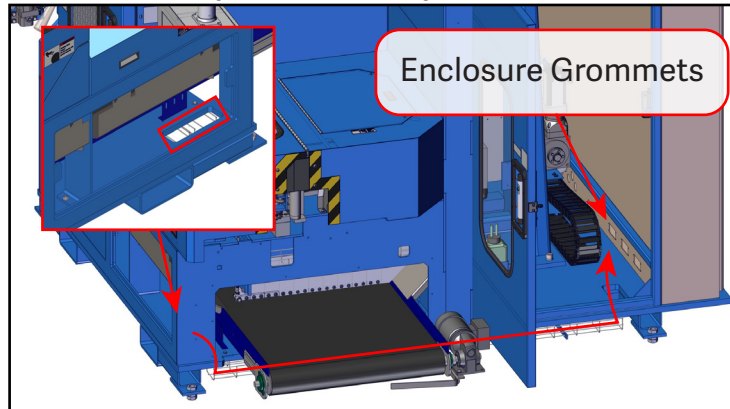

- Inside the stroke / elevation chamber, identify a grommet assembly that contains one more blank / unused plugs.
- Remove the 2 bolts (marked A in Figure 6) from the top grommet bracket.

Figure 6: Grommet Bracket Bolt Removal

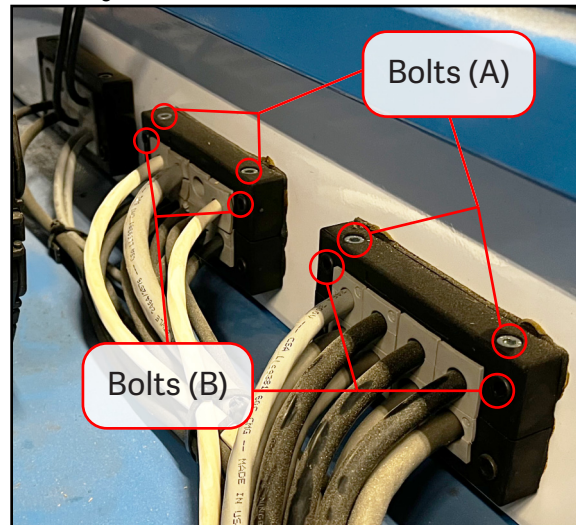

- To remove the next 2 bolts securing the grommet bracket (marked B in [Figure 6](#)), one person must hold the nuts on the electrical enclosure side while the bolts are loosened inside the stroke / elevation chamber.

Figure 7: Grommet Bracket Nuts on Enclosure Side



- Replace one of the solid grommet plugs with the supplied cable grommet. Push the cable through the open grommet (see [Figure 5](#)).
- Reverse steps [11](#) and [12](#) to reinstall the grommet bracket.
- Cut the connector off the end of supplied signal cable and use a wire stripper to pull back the shielding. There will be 3 wire strands (black, brown, and blue).
- Route the signal cable through the cable runners along the edges of the electrical enclosure to the approximate location shown in [Figure 8](#).

Figure 8: Enclosure Routing Recommendation

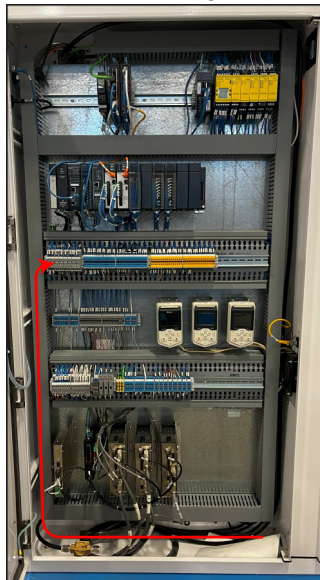

17. Connect the black wire from the signal cable to F2:2 on the terminal block shown in [Figure 9](#).

Figure 9: Terminal Block Connection

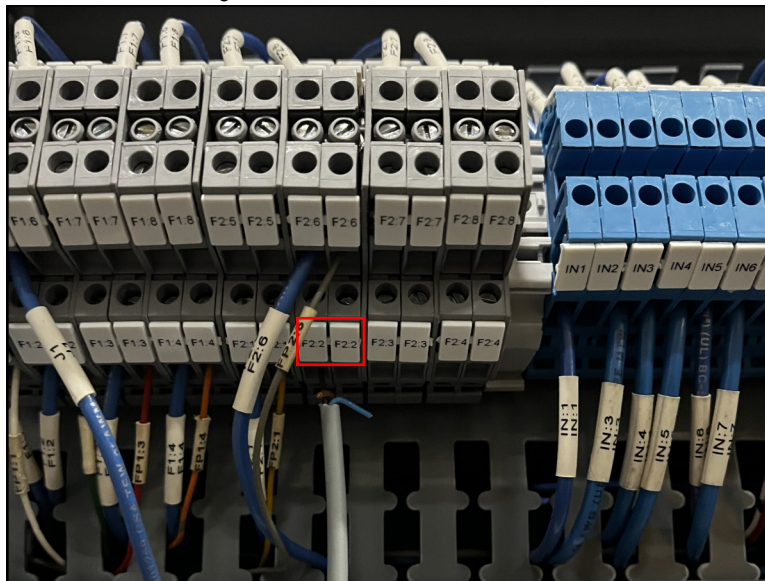

18. Secure the ends of two free wires (brown and blue) with electrical tape to prevent a potential electrical short.
19. Remove lockout/tagout devices and power on the saw.
20. Once the saw is powered on, verify that all lights on the LASM Assembly Input Module are green.
21. Close the stroke / elevation chamber door on the infeed and outfeed end of the saw.

END OF SERVICE BULLETIN