

Service Bulletin

Machinery Affected: *BLADE™* wood processing system and
Power Framer™

Document: SB211

Title: Replacing a Regulator With a *Parker™* Regulator

Applies To: *Norgren®* or *Rexroth™* Existing Regulators

Distribution: Upon Order



Copyright © 2015 MiTek®. All rights reserved.

MiTek Machinery Division
301 Fountain Lakes Industrial Drive
St. Charles, MO 63301
Phone: 800-523-3380
www.mii.com

Item # and Rev.	SB211
Date Created	29 May 2015
Created By	R. Tucker
Reviewed by	G. Kocurek
Approved by	M. Kanjee
Revision Date	
Revised By	
Approved By	
Applicability	<i>BLADE:</i> frames 1-65 <i>Power Framer:</i> refer to effectivity date
Effectivity	March 2015

Purpose and Scope



If the regulator being replaced is already a *Parker* brand, disregard this Service Bulletin and use the existing hardware for an easy, direct replacement.

If using the *Parker* regulator in this kit to replace a *Norgren* or *Rexroth* regulator, follow the procedure in this Service Bulletin. The regulators affected by this part change are for the following components.

BLADE:

- Infeed top clamp (Kit A)
- Printer (Kit A)
- Infeed side clamp (Kit A)
- Outfeed clamp (Kit B)

Power Framer:

- Clamping motor air clutch (Kit A)

Overview

The parts included in this kit are shown in Table 1-1. Please ensure all parts are present before starting this procedure.

Table 1-1: Parts in SB211KIT-A: *BLADE* Top Clamp, Printer, Infeed Side Clamp, Power Framer Clamping Motor Air Clutch.

Qty.	Part Description	Part #
1	Regulator, 30 psi (incl. bracket, gauge, plug)	438031
2	Screw 10-32x5/16"	326104
2	lock washer	364026
2	flat washer	365109

Table 1-2: Parts in SB211KIT-B: *BLADE* Outfeed Clamp

Qty.	Part Description	Part #
1	Regulator, 60 psi (incl. bracket, gauge, plug)	438586
2	Screw 10-32x5/16"	326104
2	lock washer	364026
2	flat washer	365109

Before beginning the procedure, gather the supplies listed in Table 1-3. If you have any questions, call MiTek Machinery Division Customer Service at 800-523-3380.



Table 1-3: Customer-Supplied Items

drill handle and #21 bit (approx. 5/32")	plumber's tape
tap handle and 10-32 tap	tape measure
standard wrench set	Allen wrench set

Procedure





Electrical Lockout/Tagout Procedures

	 WARNING
	<p>ELECTROCUTION HAZARD!</p> <p>Verify that all power to the machine has been turned off and follow approved lockout/tagout safety procedures before performing any maintenance.</p> <p>All electrical work must performed by a qualified electrician.</p> <p>If it is absolutely necessary to troubleshoot an energized machine, follow NFPA 70E for proper procedures and personal protective equipment.</p>

When Working on a Machine Outside the Machine’s Main Electrical Enclosure

Before performing maintenance on any machine with electrical power, lockout/tagout the machine properly. When working on a machine outside of the machine’s main electrical enclosure, not including work on the electrical transmission line to the machine, follow your company’s approved lockout/tagout procedures which should include, but are not limited to the steps here.

1. Engage an E-stop on the machine.
2. Turn the disconnect switch handle on the machine’s main electrical enclosure to the “off” position. See Figure 1.



	 WARNING
	<p>ELECTROCUTION HAZARD.</p> <p>When the disconnect switch is off, there is still live power within the disconnect switch’s enclosure. Always turn off power at the building’s power source to the equipment before opening this electrical enclosure!</p>

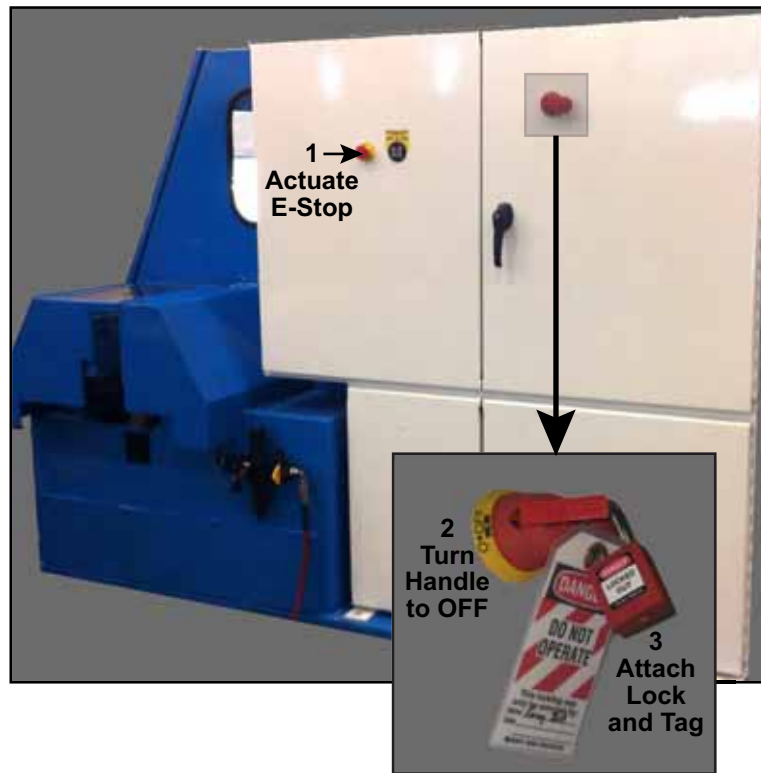

3. Attach a lock and tag that meets OSHA requirements for lockout/tagout.

Figure 1: Lockout/Tagout on the *BLADE* Main Electrical Enclosure



Pneumatic System Lockout/Tagout Procedure

	 WARNING
	<p>MOVING PARTS CAN CRUSH AND CUT.</p> <p>Always verify that power to the machine has been turned off and follow approved lockout/tagout procedures.</p> <p>Turn off the air switch before performing any maintenance on the equipment.</p>

	 WARNING
	<p>HIGH PRESSURE HAZARD.</p> <p>Bleed pneumatic lines before performing any maintenance on the pneumatic system.</p>

Location of Regulators

Figure 2: *BLADE* Top Clamp Regulator

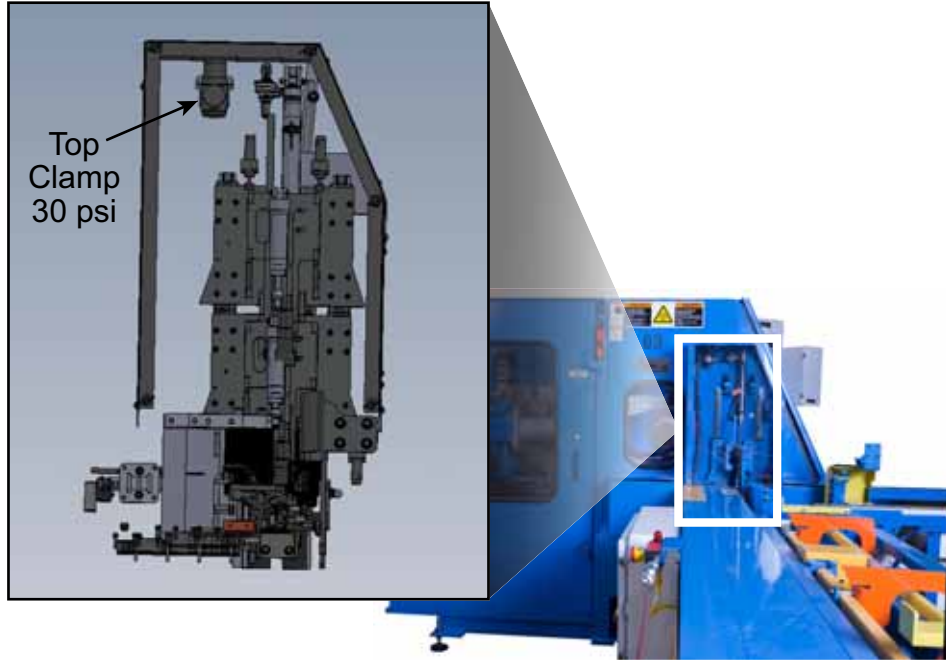

Figure 3: *BLADE* Printer Supply Chamber When Finished (recommended locations)

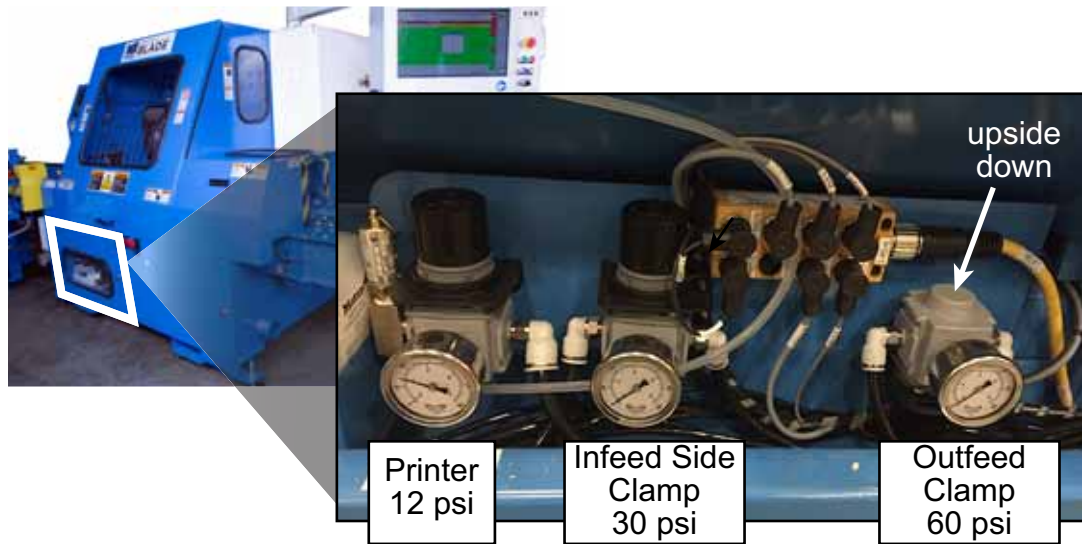
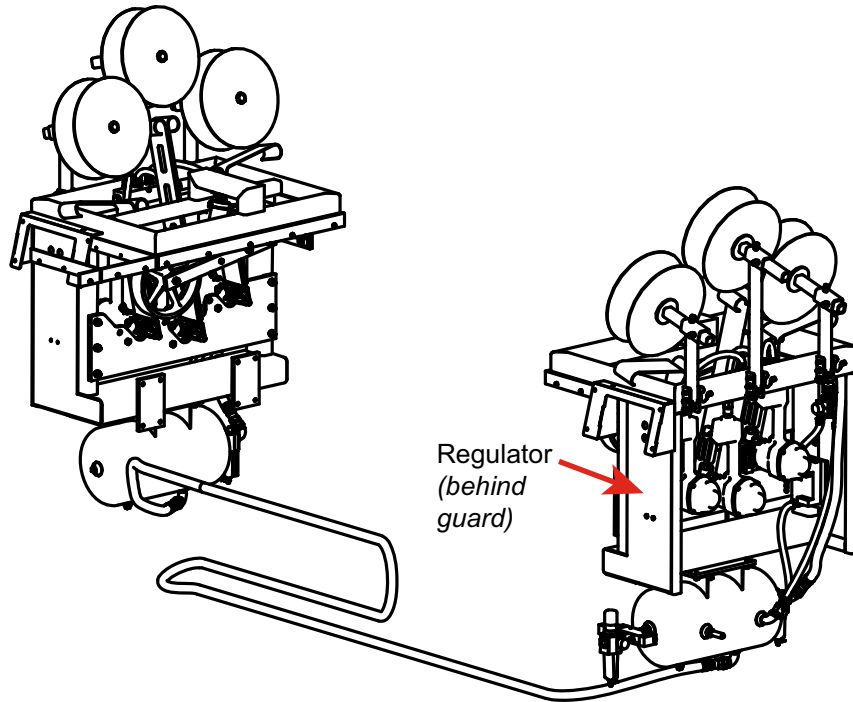

Figure 4: Power Framer Regulator for Clamping Motor Air Clutch



If the regulator being replaced is a *Parker* brand, disregard this Service Bulletin and use the existing hardware for an easy, direct replacement.

Replacing a Regulator

If replacing an old-style regulator with a *Parker* brand regulator, follow these instructions.

1. Refer to Figure 2, Figure 3, and Figure 4 to locate the correct regulator. If replacing a regulator in Figure 3, ensure that the actual order of the regulators match the labels on the saw and the image in Figure 3.
2. Remove the old regulator:
 - a) Disconnect the hoses from the regulator, keeping the current hoses and fittings for re-use.
 - b) Remove the regulator and mounting bracket from the permanent bracket or housing it's connected to. Discard the faulty regulator and its mounting bracket. See Figure 5 for an example of the mounting bracket.

Figure 5: Mounting Bracket

Mounting bracket shown bent up.

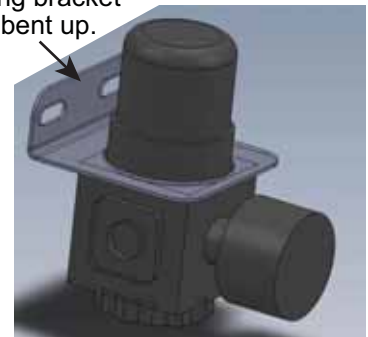

3. Drill new holes, using Figure 6 or Figure 7 as guidance.
 - a) Measuring from the existing hole(s) (circled in red) in Figure 6 or Figure 7, mark the new hole(s) indicated by a solid, green circle.
 - b) Drill and tap the new hole(s) using a #21 drill bit and 10-32 tap.

Figure 6: Holes for *BLADE* Top Clamp and Power Framer

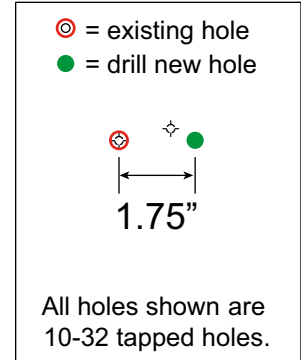
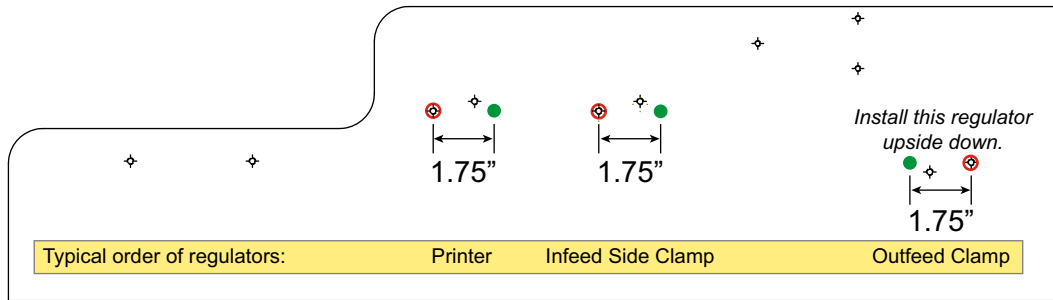

Figure 7: Holes for *BLADE* Printer, Infeed Side Clamp, and Outfeed Clamp



All holes shown are 10-32 tapped holes.

4. Assemble the new regulator and mounting bracket with these steps.

- a) Verify that all parts of the regulator assembly labeled in Figure 8 are present.
- b) Attach the mounting bracket to the regulator:

Figure 8: Regulator Parts

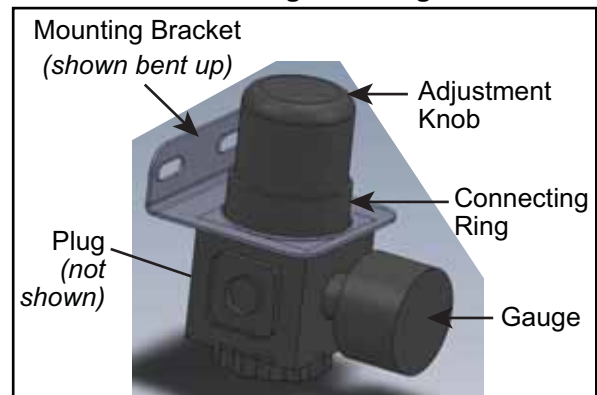

- 1) If the connecting ring is already on the knob, unscrew the connecting ring and remove it from the regulator.
- 2) Position mounting bracket and regulator as described in Table 2.

Table 2: Air Pressure Settings for Each Regulator

Regulator For...	Position of Bracket	Position of Regulator
<i>BLADE</i> Top clamp	Bends up	Knob faces up
<i>BLADE</i> Printer	Bends down	Knob faces up
<i>BLADE</i> Infeed side clamp	Bends down	Knob faces up
<i>BLADE</i> Outfeed clamp	Bends down	Knob faces down
<i>Power Framer</i> clamping motor air clutch	Determine which way fits best in your assembly	

- 3) Slide regulator knob through the large hole in mounting bracket.
- 4) Screw connecting ring onto the knob so it lightly sandwiches the mounting bracket.
- 5) Before tightening completely, orient the regulator correctly:
 - The two smaller holes must be on the front and back of the regulator.
 - The arrow shown on the regulator must be pointing in the direction of the air flow.
- 6) Tighten the connecting ring firmly.
- c) Place the plug into the hole on the back side of the regulator.
- d) Using plumber's tape on the threads, screw the gauge into the hole on the front side of the regulator.

5. Screw the mounting bracket/regulator assembly to its permanent bracket or housing using the hardware supplied in this kit, as shown in Figure 9.

Be sure to use the holes highlighted in Figure 6 or Figure 7.

6. Attach the pneumatic hoses:
 - a) Using the existing pneumatic fittings, wrap them with new plumber's tape.
 - b) Reconnect the incoming and outgoing hoses to the correct sides of the regulator, so air will flow in the direction indicated by the arrows on the regulator.
7. Remove the lockout/tagout devices, and turn the power and pneumatic systems on.
8. Continue this procedure to set the pneumatic settings.

Figure 9: Hardware Use

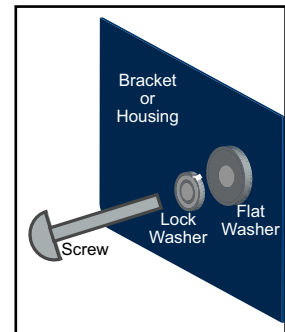

9. Adjust the regulator, if necessary, and lock the setting as indicated below. Note that this step is written for upright facing regulators, so reverse the direction of movement for the outfeed clamp regulator.
 - a) Lift up on the knob (away from the regulator body) and turn until the gauge reads the appropriate setting as listed in Table 3. The settings are also shown on page 5.
 - clockwise raises the pressure up on upright facing regulators
 - counterclockwise reduces the pressure on upright facing regulators
 - b) Push the knob down (toward the regulator body) to lock it in place.

Table 3: Air Pressure Settings for Each Regulator

Regulator For...	Correct Pressure Setting
<i>BLADE</i> Top clamp	maximum capacity of 30 psi
<i>BLADE</i> Printer	12 psi
<i>BLADE</i> Infeed side clamp	maximum capacity of 30 psi
<i>BLADE</i> Outfeed clamp	maximum capacity of 60 psi
<i>Power Framer</i> clamping motor air clutch	8-15 psi

Figure 10: New Bracket and Regulators Installed

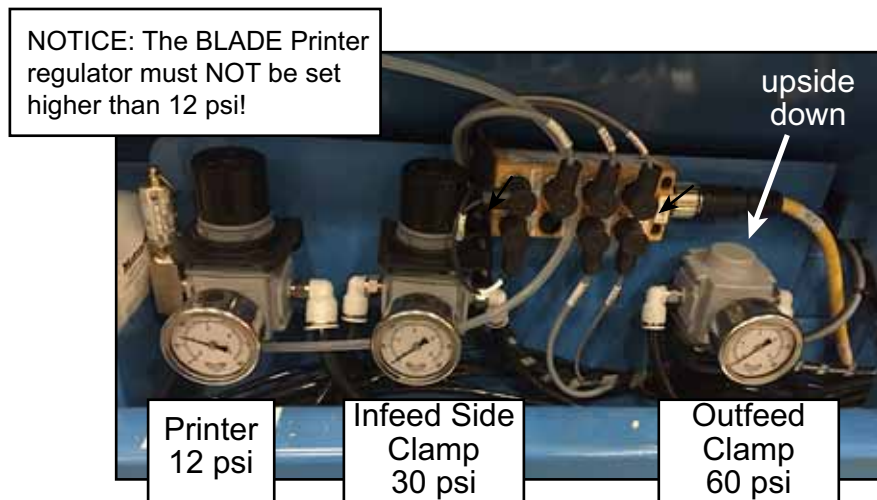

END OF SERVICE BULLETIN