

Service Bulletin

Machinery Affected: Horizontal Stacker
Document: SB182
Title: Replacing a *GE® QuickPanel Jr.* 5-in. Touch Screen with a *GE QuickPanel Jr.* 6-in. Touch Screen
Applies To: All *GE® QuickPanel Jr.* 5-in. Touch Screens
Distribution: Customers, Upon Order



Copyright © 2008 MiTek®. All rights reserved.

MiTek
Machinery Division
301 Fountain Lakes Industrial Drive
St. Charles, MO 63301
Phone: 800-523-3380
Sales fax: 636-328-9222
Customer Service fax: 636-328-9218
www.mii.com

Date Created	3 January 2008
Created By	R. Widder
Reviewed by	R. Tucker
Approved by	G. McNeelege
Manuf. Eng.	G. Balke
Applicability	PN 504454
Effectivity	All



Purpose and Scope

GE[®] is discontinuing the 5-in. QuickPanel Color-STN touch screen. As a result, all 5-in. touch screens that need to be replaced must be replaced with a 6-in. QuickPanel Color-STN touch screens. Since this screen is not an exact replacement, the cutout in the enclosure must be enlarged to accommodate the new screen.

Overview

The parts included in this kit are shown in Table 1. Please ensure all parts are present before starting this procedure.

Table 1: Parts in SB182 KIT

Qty.	Part Description	Part #
1	Touch screen, GE, 6"	92116
1	Service Bulletin 182	SB182

Before beginning the procedure, gather the supplies listed in Table 2.

Table 2: Customer-Supplied Items

Qty.	Part Description
1	Tape measure
1	Grease pencil or marker
1	Reciprocating saw with metal cutting blade
1	File
1	Standard screwdriver set
1	Phillips screwdriver set

If you have any questions, call MiTek Machinery Division Customer Service at 800-523-3380.

Procedure



Electrical Lockout/Tagout Procedures

WARNING	
	<p>ELECTROCUTION HAZARD!</p> <p>Verify that all power to the machine has been turned off and follow approved lockout/tagout safety procedures before performing any maintenance.</p> <p>All electrical work must performed by a qualified electrician.</p> <p>If it is absolutely necessary to troubleshoot an energized machine, follow NFPA 70E for proper procedures and personal protective equipment.</p>

Before performing maintenance on any machine with electrical power, lockout/tagout the machine properly. When working on a machine outside of the machine’s main electrical enclosure, not including work on the electrical transmission line to the machine, follow your company’s approved lockout/tagout procedures which should include, but are not limited to the steps here.

1. Engage an E-stop on the machine.
2. Turn the disconnect switch handle on the machine’s main electrical enclosure to the “off” position. See Figure 1.

WARNING	
	<p>ELECTROCUTION HAZARD.</p> <p>When the disconnect switch is off, there is still live power within the disconnect switch’s enclosure. Always turn off power at the building’s power source to the equipment before opening this electrical enclosure!</p>

3. Attach a lock and tag that meets OSHA requirements for lockout/tagout.

Figure 1: Sample of Lockout/Tagout on the Main Electrical Enclosure

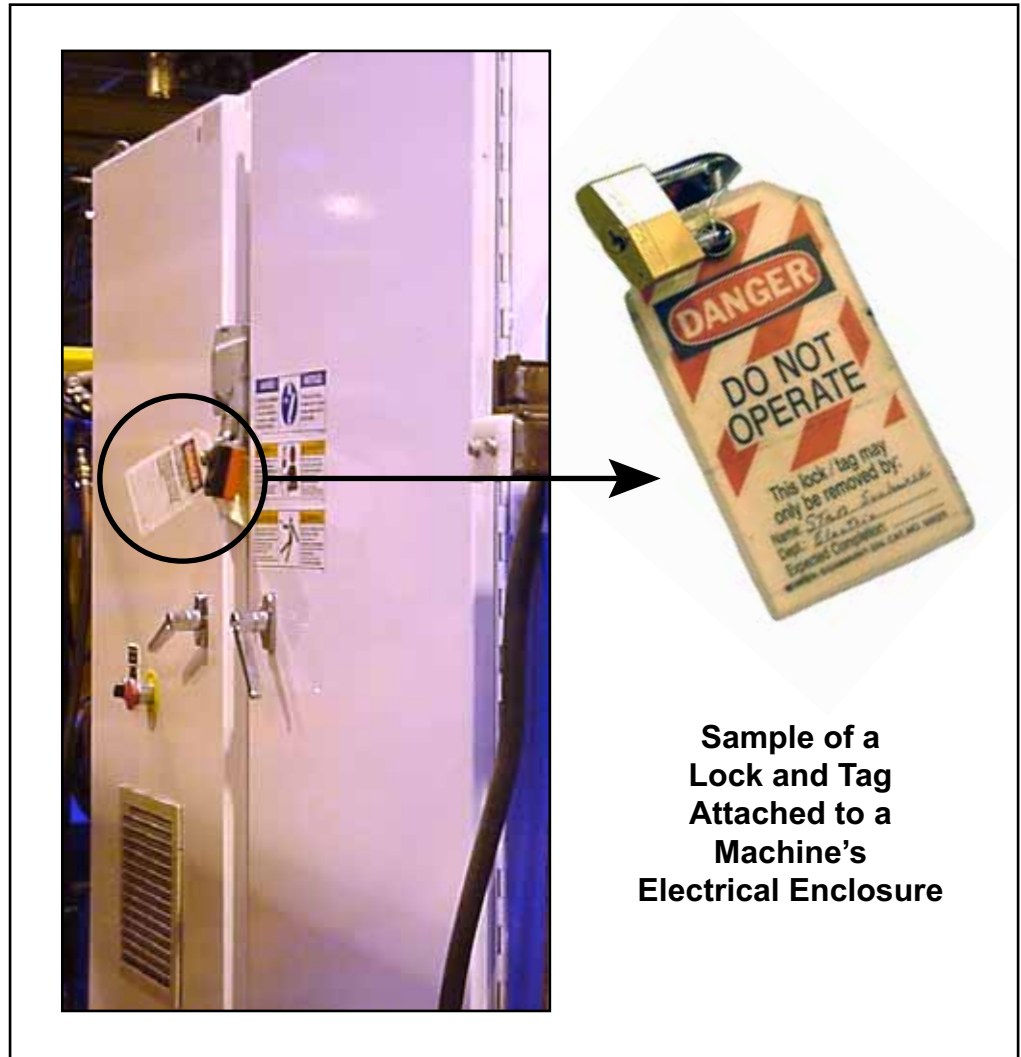

Hydraulic System Lockout/Tagout Procedure

WARNING	
	<p>MOVING PARTS CAN CRUSH AND CUT.</p> <p>Always verify that power to the machine has been turned off and follow approved lockout/tagout procedures.</p> <p>Turn off the shutoff valve before performing any maintenance on the equipment.</p>

WARNING	
	<p>HIGH PRESSURE HAZARD.</p> <p>Bleed hydraulic lines before performing any maintenance on the hydraulic system.</p>

Replacing the Touch Screen

Removing the Touch Screen

1. Disconnect the wiring from the touch screen, noting how it is wired.
2. Disconnect the communications cable from the touch screen, noting how it is connected.
3. Unscrew the screws that hold the touch screen in place.
4. Remove the panel clamps from the slots in the display body.
5. Remove the display from the panel opening.

Enlarging the Cutout

The cutout that was created for the 5-in. display was 6.22 in. wide by 4.45 in. high. For the 6-in. display, the height of the cutout must be enlarged to 4.86 in. high. To enlarge the cutout:

1. Mark the location of the new cutout on the top side of the existing cutout. See Figure 2.

Figure 2: Enlarging the Cutout

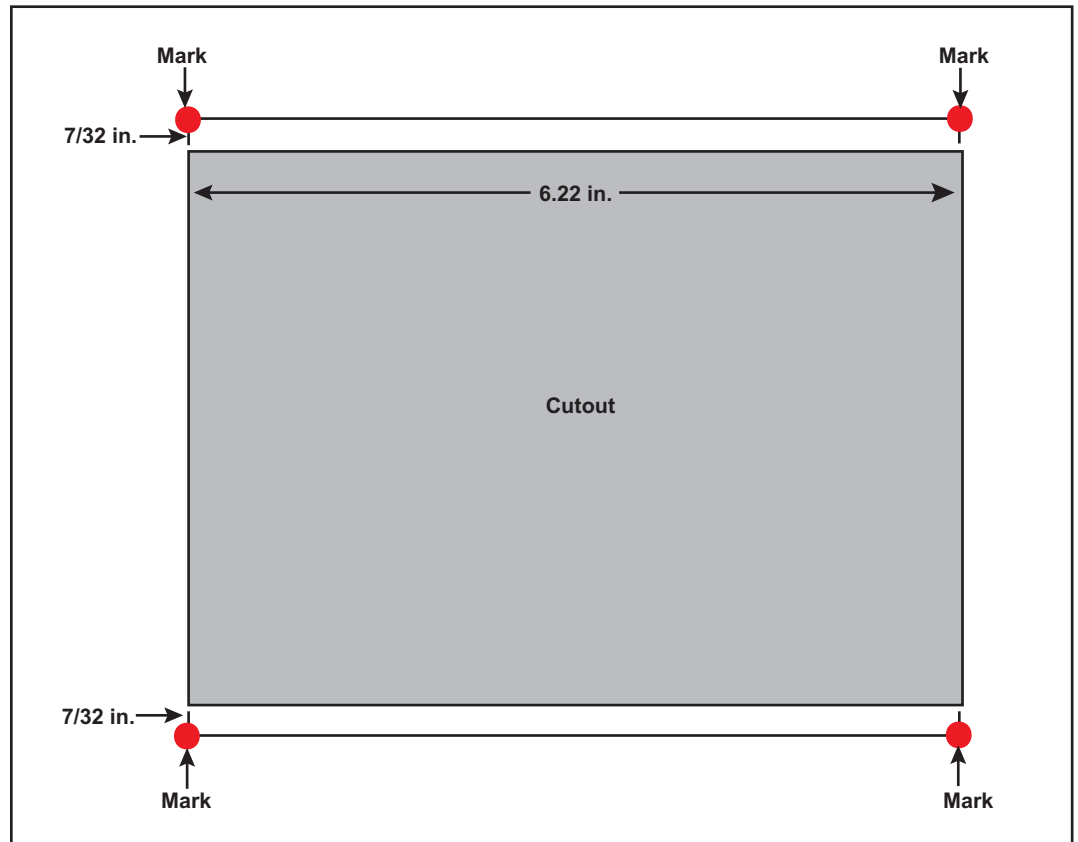

- a) Using a tape measure or ruler, measure $7/32$ in. above of the top left corner of the cutout. Mark the location with a marker or grease pencil.
- b) Measure $7/32$ in. above the top right corner of the cutout. Mark the location with a marker or grease pencil.
- c) Using a straight edge, draw a line between the two marks.
- d) Using a straight edge, draw a line from the left mark to the top left corner of the cutout.
- e) Using a straight edge, draw a line from the right mark to the top right corner of the cutout.

2. Mark the location of the new cutout on the bottom side of the existing cutout.
 - a) Using a tape measure or ruler, measure $7/32$ in. below the bottom left corner of the cutout. Mark the location with a marker or grease pencil.
 - b) Measure $7/32$ in. below the bottom right corner of the cutout. Mark the location with a marker or grease pencil.
 - c) Using a straight edge, draw a line between the two marks.
 - d) Using a straight edge, draw a line from the left mark to the bottom left corner of the cutout.
 - e) Using a straight edge, draw a line from the right mark to the bottom right corner of the cutout.
3. Use the reciprocating saw to cut along the lines and enlarge the cutout.
4. Remove any burrs using the file. Make sure the edge are smooth.

Inserting the New Touch Screen

1. Install the gasket in the slot of the touch screen faceplate.
2. Insert the display through the panel opening.
3. Insert the panel clamps into the slots in the display body and tighten the screws.

Connecting Power and Communications to the Touch Screen

1. Remove the protective cover from the DC terminal strip on the back of the touch screen.
2. Connect the power supply wires to the terminals at the appropriate locations. See Drawing 90436 and Figure 3.

Figure 3: Power and Communications Connections

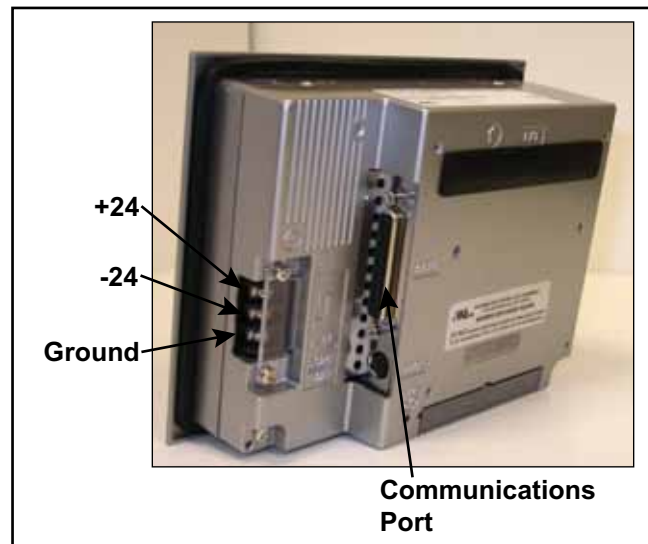

3. Tighten the terminal screws.
4. Put the protective cover back in place.
5. Connect the communications cable from the PLC to the touch screen at the 24-pin connection. See Figure 3.
6. Restore power to the machine.

HEATER PANEL - SCHEMATIC

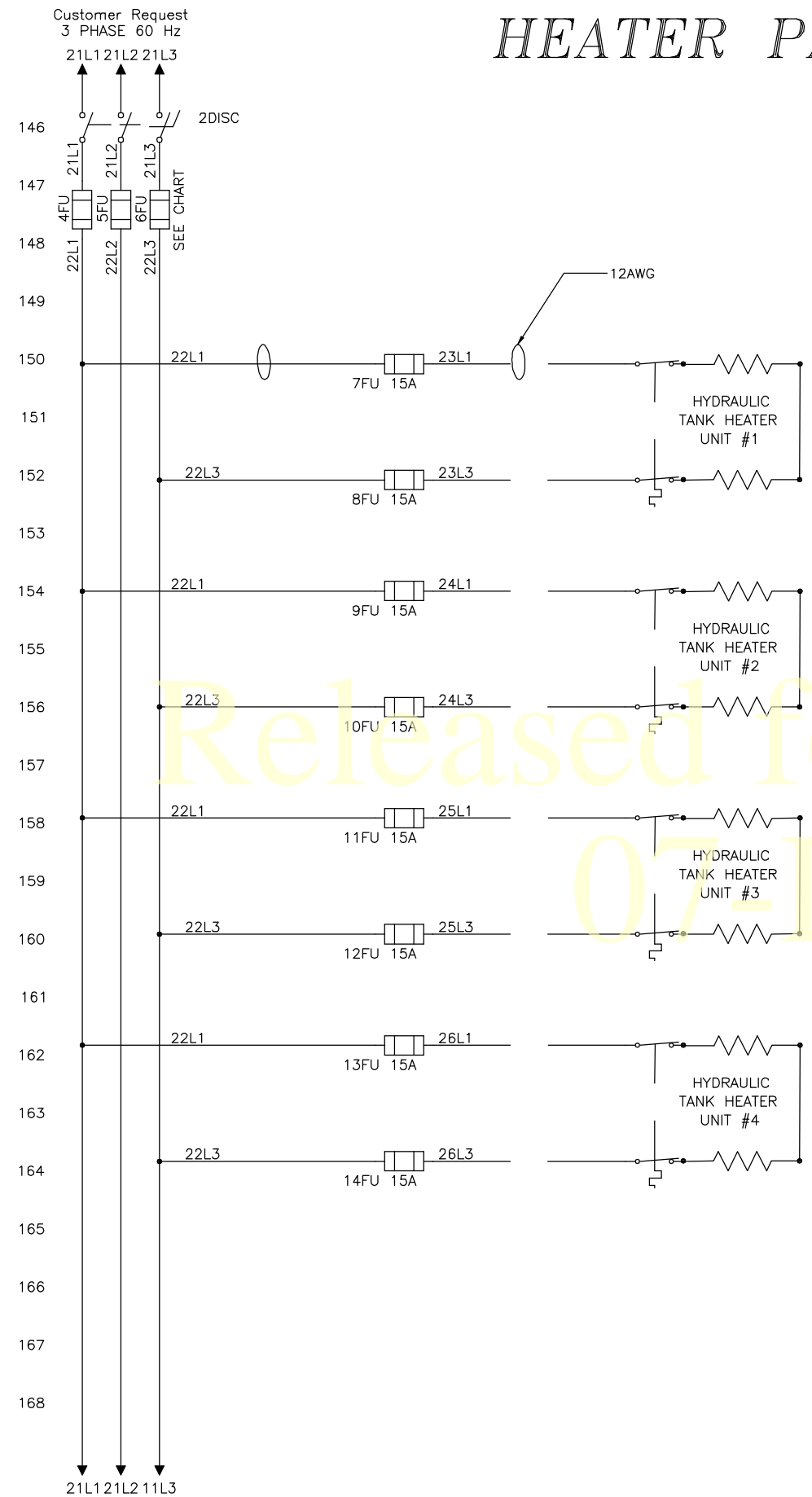

VAC	FU4-6
460	30A
230/208	50A

Released for Production
07 Dec-21

ITEM	QTY.	PART NAME	MATERIAL AND/OR DESCRIPTION	LENGTH	CODE	DWG. NO./PART NO.
DIMENSION TOLERANCES, UNLESS OTHERWISE SPECIFIED: FRACTIONS ± [1/32] DECIMALS ± [0.010] ANGLES ± [1°]			THIS DRAWING AND/OR DATA SHEET, AND THE CONFIDENTIAL PROPRIETARY INFORMATION THEREON, IS PROPERTY OF MITEK INDUSTRIES, INC. AND IS NOT TO BE REPRODUCED OR COPIED IN WHOLE OR IN PART, OR USED FOR UNAUTHORIZED MANUFACTURING OR ANY OTHER EXPLOITATION OF THE ITEM DISCLOSED THEREIN, OR IN ANY OTHER WAY DISCLOSED OR USED FOR FURNISHING INFORMATION.			
TOTAL RUNOUT ± [] MACHINED SURFACES NOT SPECIFIED [70°]			FEATURES: ELECTRICAL SCHEMATIC			
APPROVED: VDC DATE: MFG.			HORIZONTAL STACKER, 2/4-ZONE			
CHECKED	DATE	DRAWN	DATE	FINISH PAINT	SCALE	PAGE
		VCarroll	2/22/02	X	NONE	2 of 22
					DASH NO.	REV.
					B90436	G

MiTek Industries, Inc.
4203 SHORELINE DRIVE, EARTH CITY, MO. 63045

PLC CONTROL PANEL - SCHEMATIC (120VAC)

REV.	DATE	DESCRIPTION	BY	CHKD	APPD	DATE
------	------	-------------	----	------	------	------

CHART 1

VAC	FU1-4	T1 JUMPERS
460	4A	H2-H3
230	8A	H1-H3, H4-H2
208	8A	L1-H1, L3-H2

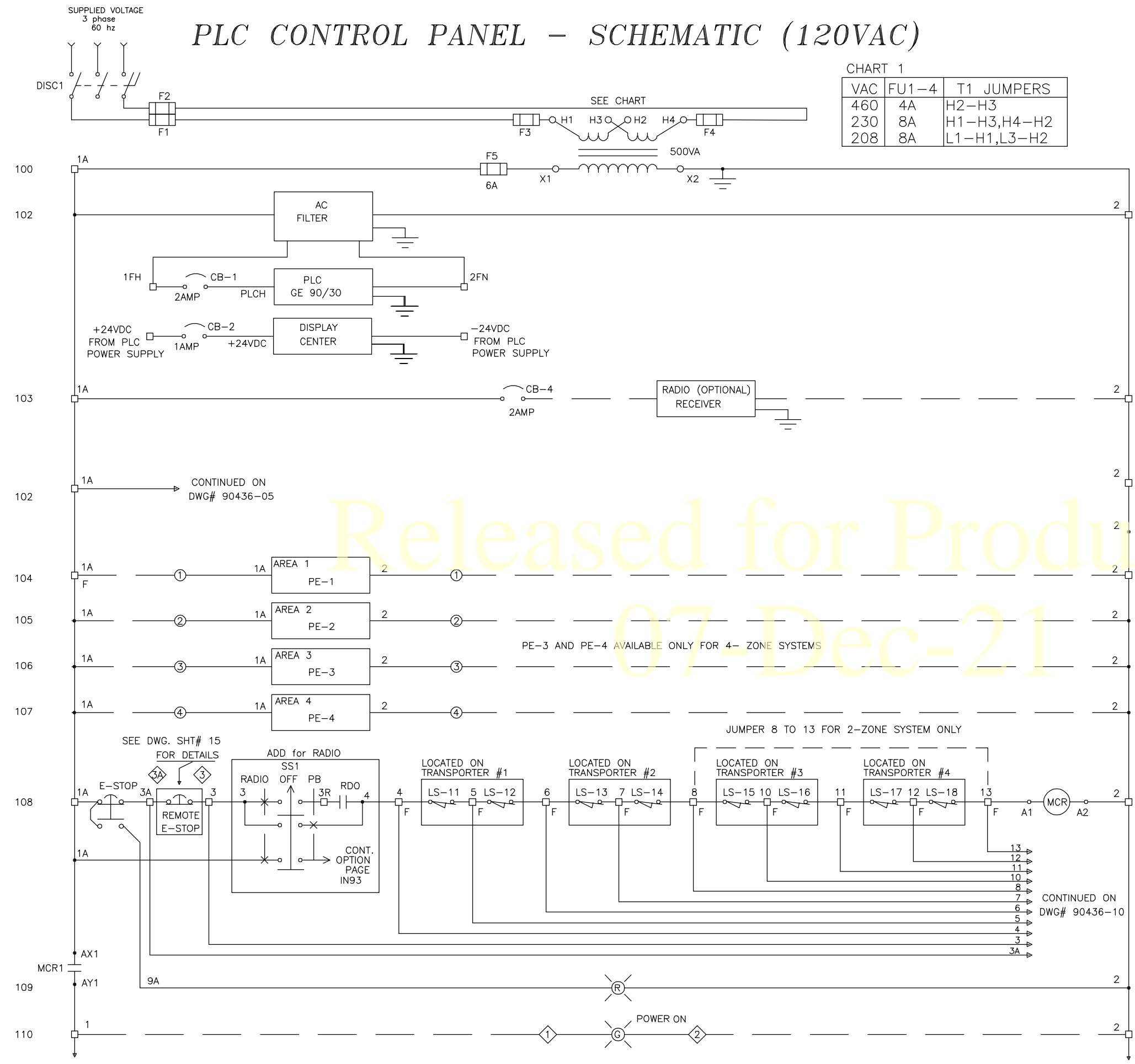

- MOTOR CONTROL PANEL (2 ZONE)
- MOTOR CONTROL PANEL (4 ZONE)
- ◇ PUSH BUTTON PANEL
- ① TRANSPORTER #1 J-BOX
- ② TRANSPORTER #2 J-BOX
- ③ TRANSPORTER #3 J-BOX
- ④ TRANSPORTER #4 J-BOX

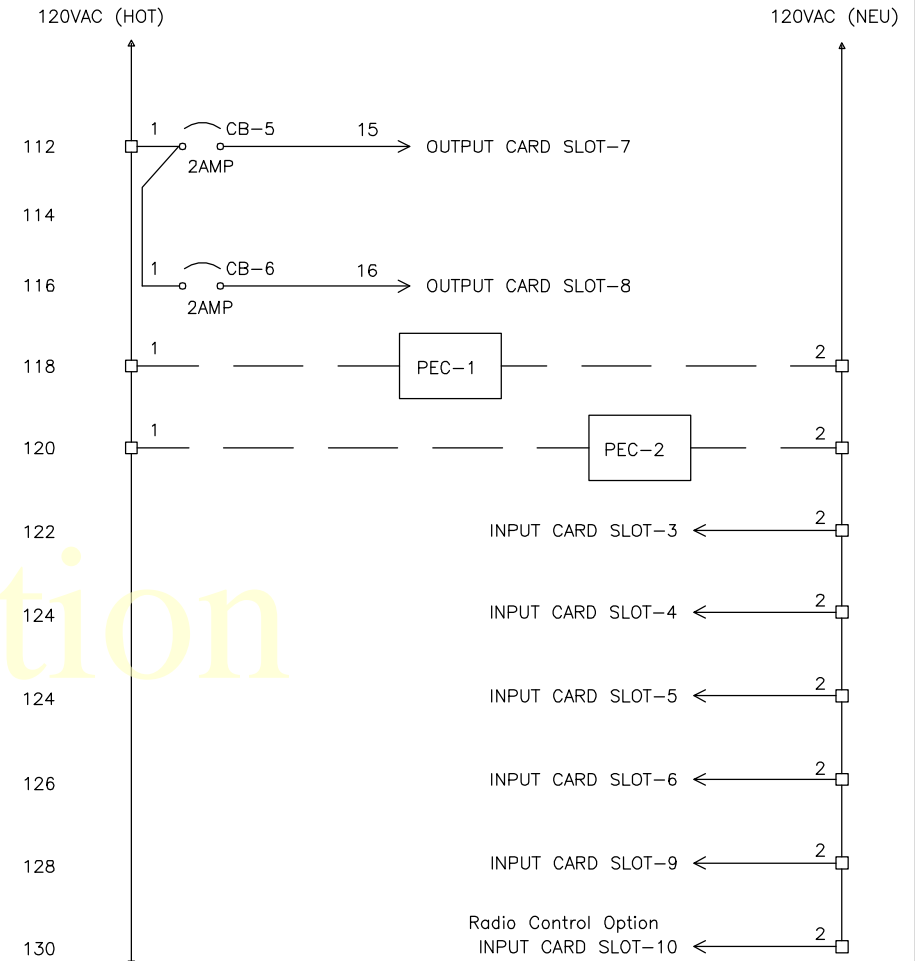

Released for Production
07-Dec-21

ITEM	QTY.	PART NAME	MATERIAL AND/OR DESCRIPTION	LENGTH	CODE	DWG. NO./PART NO.
<small>DIMENSION TOLERANCES, UNLESS OTHERWISE SPECIFIED: FRACTIONS ± [1/32] DECIMALS ± [0.010] ANGLES ± [1°] TOTAL RUNOUT ± [] MACHINED SURFACES NOT SPECIFIED [79°]</small>						
<small>THIS DRAWING AND/OR DATA SHEET, AND THE CONFIDENTIAL PROPRIETARY INFORMATION THEREON, IS THE PROPERTY OF MITEK INDUSTRIES, INC. AND IS NOT TO BE REPRODUCED OR COPIED IN WHOLE OR IN PART, OR USED FOR UNAUTHORIZED MANUFACTURING OR ANY OTHER EXPLOITATION OF THE ITEM DISCLOSED THEREIN, OR IN ANY OTHER WAY DISCLOSED OR USED FOR FURNISHING INFORMATION.</small>						
FEATURES ELECTRICAL SCHEMATIC			MiTek Industries, Inc. 4203 SHORELINE DRIVE, EARTH CITY, MO. 63045			
APPROVED	VDC	DATE	MFG.	HORIZONTAL STACKER, 2/4-ZONE		
CHECKED	DATE	DRAWN	DATE	FINISH PAINT	SCALE	PAGE
		VCarroll	2/22/02	X	NONE	3 of 22
						B90436
						DASH NO. REV. G

RACK: 1
GROUP: 0
SLOT: 3

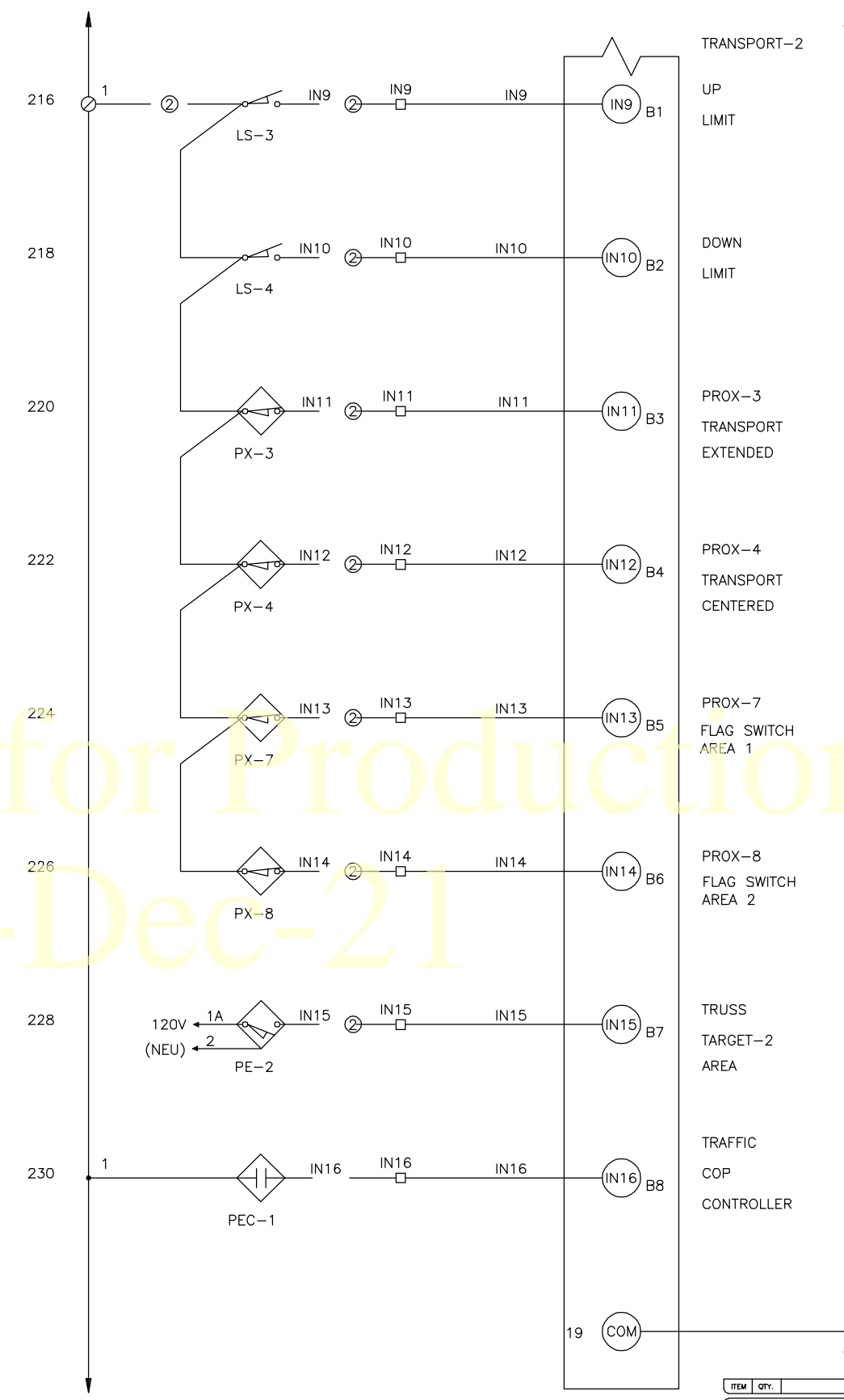
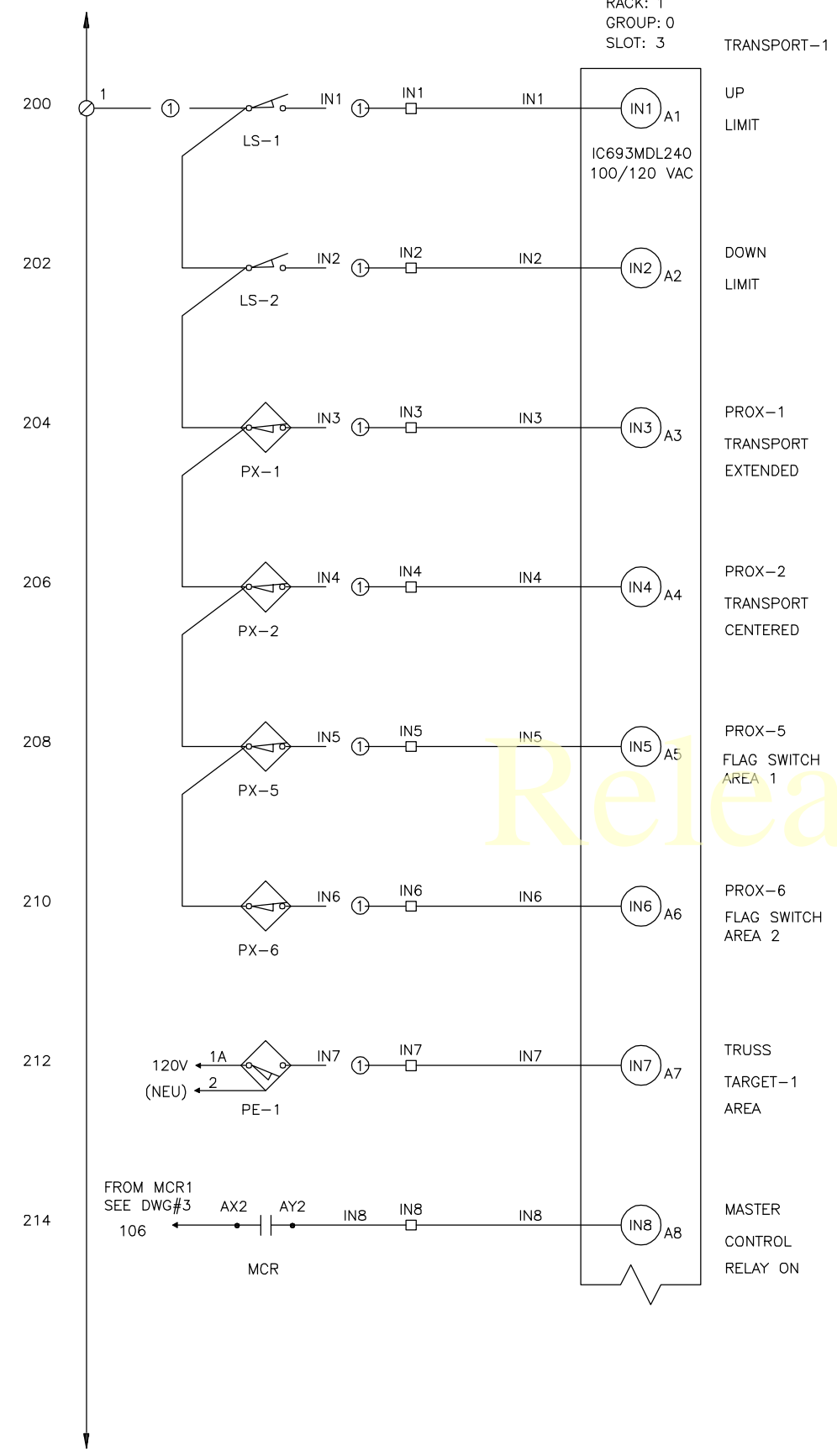

Released for Production
07-Dec-21

- ① TRANSPORTER #1 J-BOX
- ② TRANSPORTER #2 J-BOX

ITEM	QTY.	PART NAME	MATERIAL AND/OR DESCRIPTION	LENGTH	CODE	DWG. NO./PART NO.
<small>DIMENSION TOLERANCES, UNLESS OTHERWISE SPECIFIED: FRACTIONS ± [1/32] DECIMALS ± [0.01] ANGLES ± [1°] TOTAL RUNOUT ± [] MACHINED SURFACES NOT SPECIFIED [79/]</small>						
<small>THIS DRAWING AND/OR DATA SHEET, AND THE CONFIDENTIAL PROPRIETARY INFORMATION THEREON, IS PROPERTY OF MITEK INDUSTRIES, INC. AND IS NOT TO BE REPRODUCED OR COPIED IN WHOLE OR IN PART, OR USED FOR UNAUTHORIZED MANUFACTURING OR ANY OTHER EXPLOITATION OF THE ITEM DISCLOSED THEREIN, OR IN ANY OTHER WAY DISCLOSED OR USED FOR FURNISHING INFORMATION.</small>						
FEATURES ELECTRICAL SCHEMATIC			MiTek Industries, Inc. <small>4203 SHORELINE DRIVE, EARTH CITY, MO. 63045</small>			
APPROVED	VDC	DATE	MFG.	HORIZONTAL STACKER, 2/4-ZONE		
CHECKED	DATE	DRAWN	DATE	FINISH PAINT	SCALE	PAGE
		VCarroll	2/22/02	X	NONE	4 of 22
B90436						DASH NO. REV. G

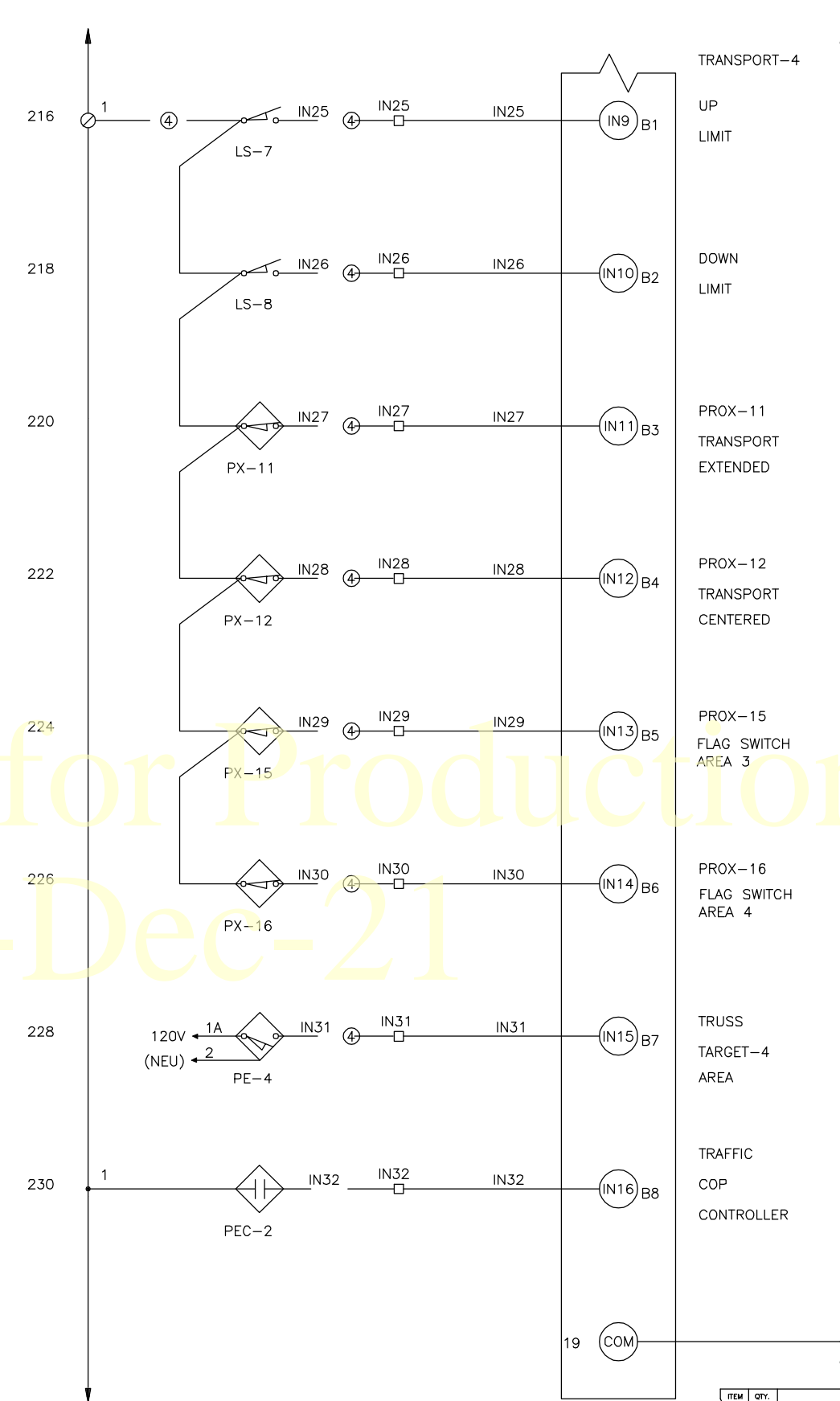
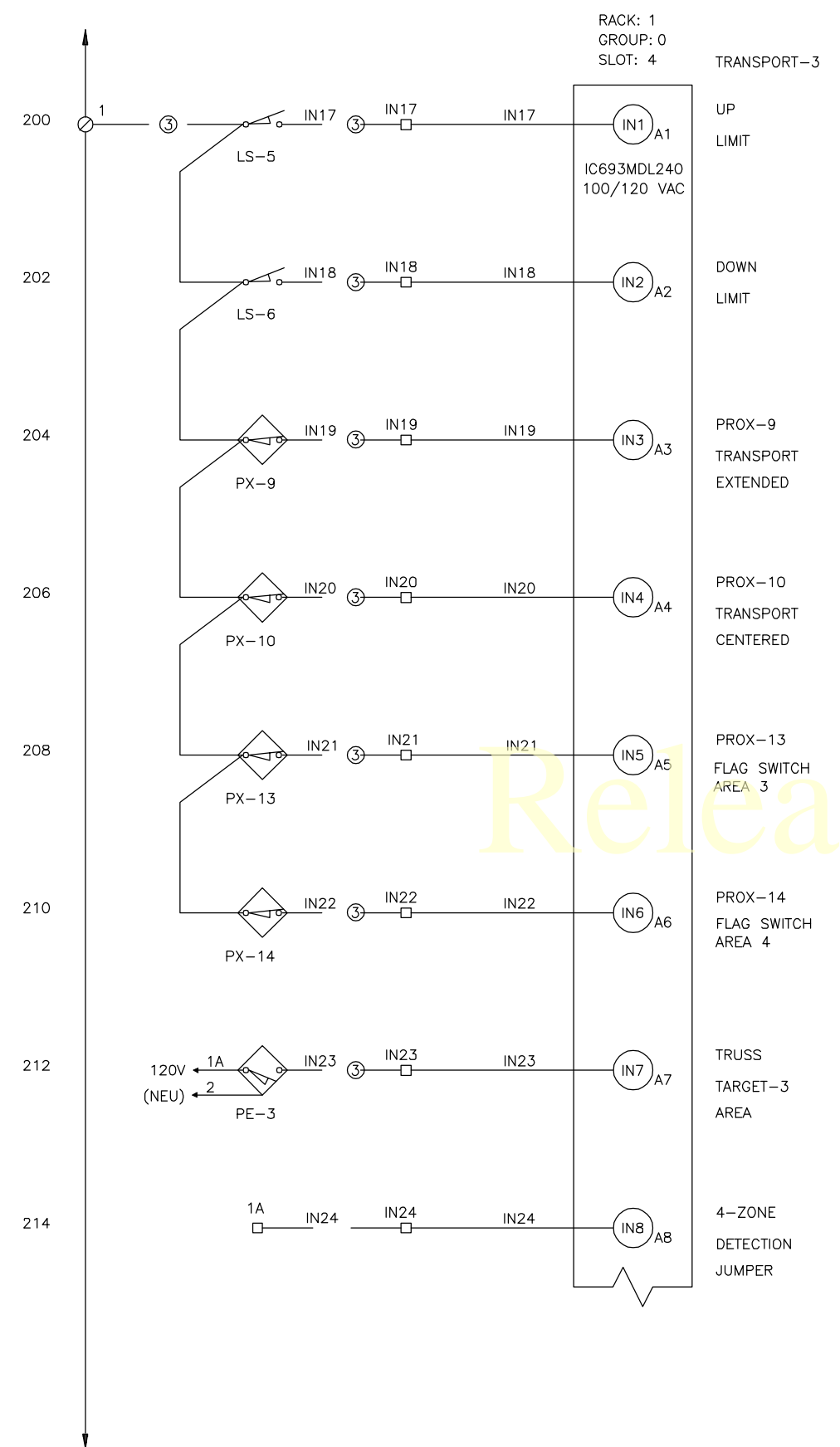

RESERVED WIRING FOR
4-ZONE SYSTEM

- ③ TRANSPORTER #3 J-BOX
- ④ TRANSPORTER #4 J-BOX

ITEM	QTY.	PART NAME	MATERIAL AND/OR DESCRIPTION	LENGTH	CODE	DWG. NO./PART NO.
<small>DIMENSION TOLERANCES, UNLESS OTHERWISE SPECIFIED: FRACTIONS ± [1/32] DECIMALS ± [0.01] ANGLES ± [1°] TOTAL RUNOUT ± [] MACHINED SURFACES NOT SPECIFIED [79°]</small>						
<small>*THIS DRAWING AND/OR DATA SHEET, AND THE CONFIDENTIAL PROPRIETARY INFORMATION THEREON, IS PROPERTY OF MITEK INDUSTRIES, INC. AND IS NOT TO BE REPRODUCED OR COPIED IN WHOLE OR IN PART, OR USED FOR UNAUTHORIZED MANUFACTURING OR ANY OTHER EXPLOITATION OF THE ITEM DISCLOSED THEREIN, OR IN ANY OTHER WAY DISCLOSED OR USED FOR FURNISHING INFORMATION.*</small>						
FEATURES ELECTRICAL SCHEMATIC			MiTek Industries, Inc. 4203 SHORELINE DRIVE, EARTH CITY, MO. 63045			
APPROVED	VDC	DATE	MFG.	HORIZONTAL STACKER, 2/4-ZONE		
CHECKED	DATE	DRAWN	DATE	FINISH PAINT	SCALE	PAGE
		VCarroll	2/22/02	X	NONE	5 of 22
B90436						DASH NO. REV. G

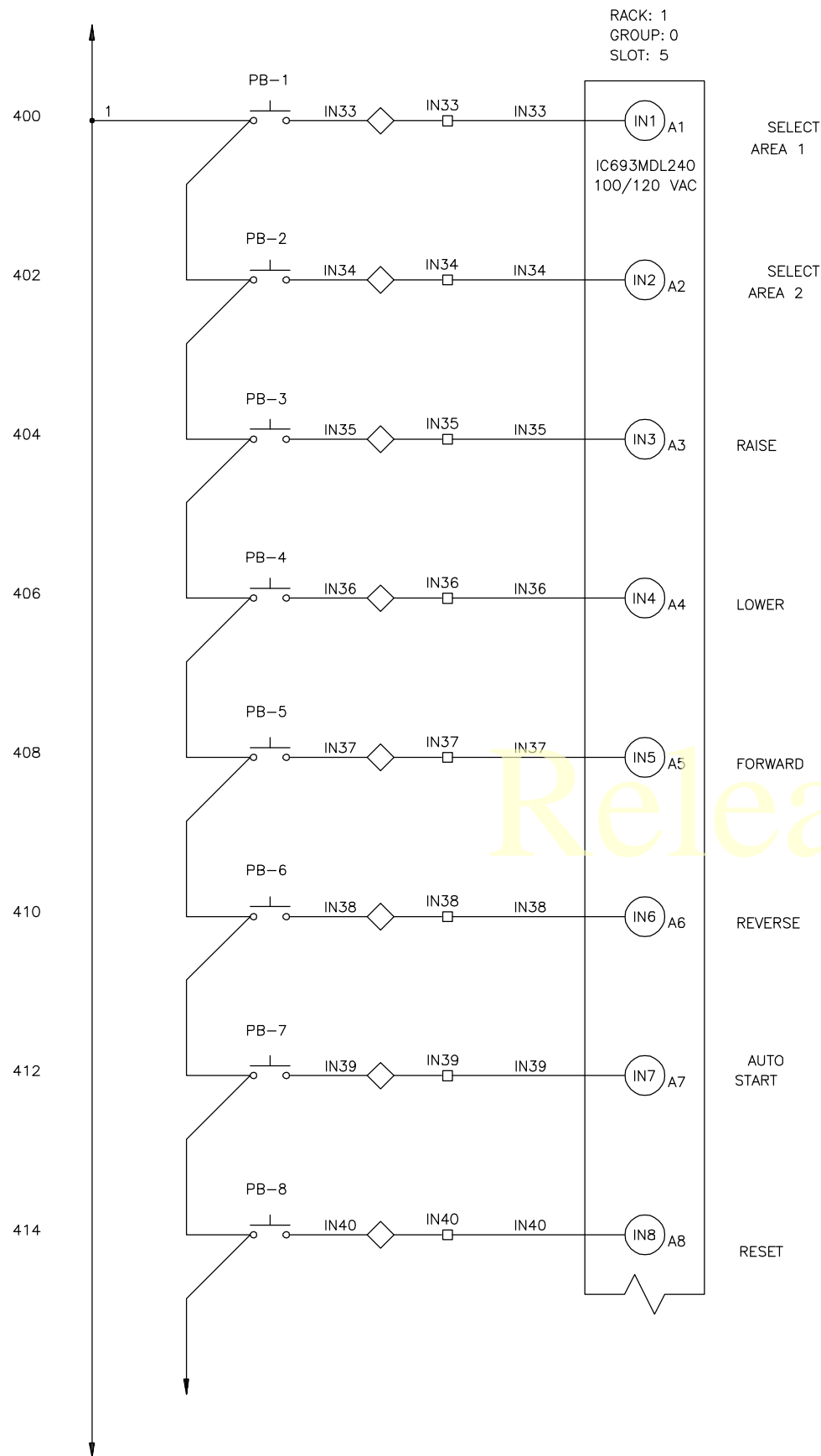

SELECT AREA 1
SELECT AREA 2
RAISE
LOWER
FORWARD
REVERSE
AUTO START
RESET

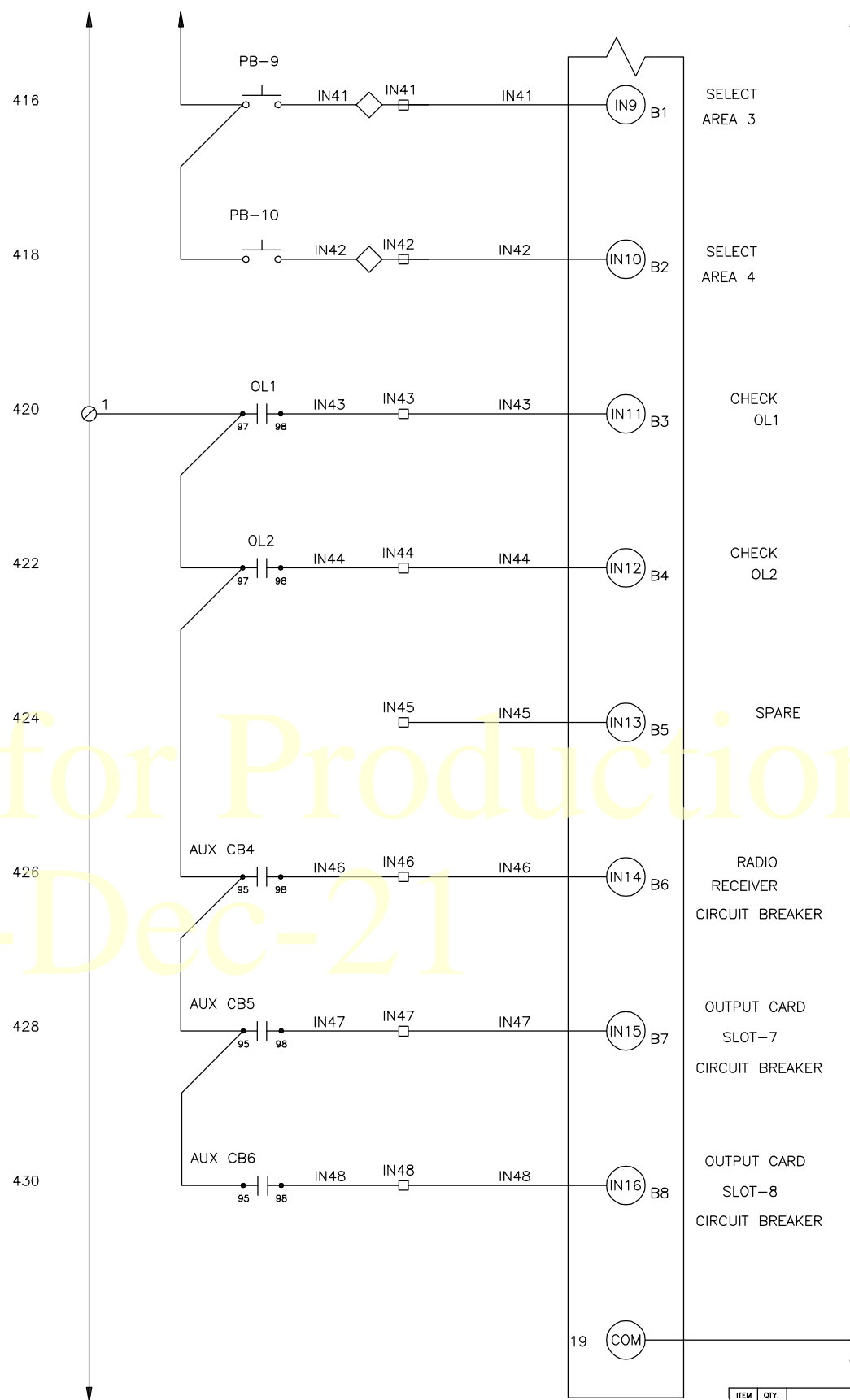

SELECT AREA 3
SELECT AREA 4
CHECK OL1
CHECK OL2
SPARE
RADIO RECEIVER CIRCUIT BREAKER
OUTPUT CARD SLOT-7 CIRCUIT BREAKER
OUTPUT CARD SLOT-8 CIRCUIT BREAKER

◇ PUSH BUTTON PANEL

Released for Production
07-Dec-21

ITEM	QTY.	PART NAME	MATERIAL AND/OR DESCRIPTION	LENGTH	CODE	DWG. NO./PART NO.
<small>DIMENSION TOLERANCES, UNLESS OTHERWISE SPECIFIED: FRACTIONS ± [1/32] DECIMALS ± [0.010] ANGLES ± [1°] TOTAL RUNOUT ± [] MACHINED SURFACES NOT SPECIFIED [79°]</small>						
<small>THIS DRAWING AND/OR DATA SHEET, AND THE CONFIDENTIAL PROPRIETARY INFORMATION THEREON, IS PROPERTY OF MITEK INDUSTRIES, INC. AND IS NOT TO BE REPRODUCED OR COPIED IN WHOLE OR IN PART, OR USED FOR UNAUTHORIZED MANUFACTURING OR ANY OTHER EXPLOITATION OF THE ITEM DISCLOSED THEREIN, OR IN ANY OTHER WAY DISCLOSED OR USED FOR FURNISHING INFORMATION.</small>						
ELECTRICAL SCHEMATIC			MiTek Industries, Inc. 4203 SHORELINE DRIVE, EARTH CITY, MO. 63045			
APPROVED	VDC	DATE	MFG.	HORIZONTAL STACKER, 2/4-ZONE		
CHECKED	DATE	DRAWN	DATE	FINISH PAINT	SCALE	PAGE
		VCarroll	2/22/02	X	NONE	6 of 22
B90436						DASH NO. REV. G

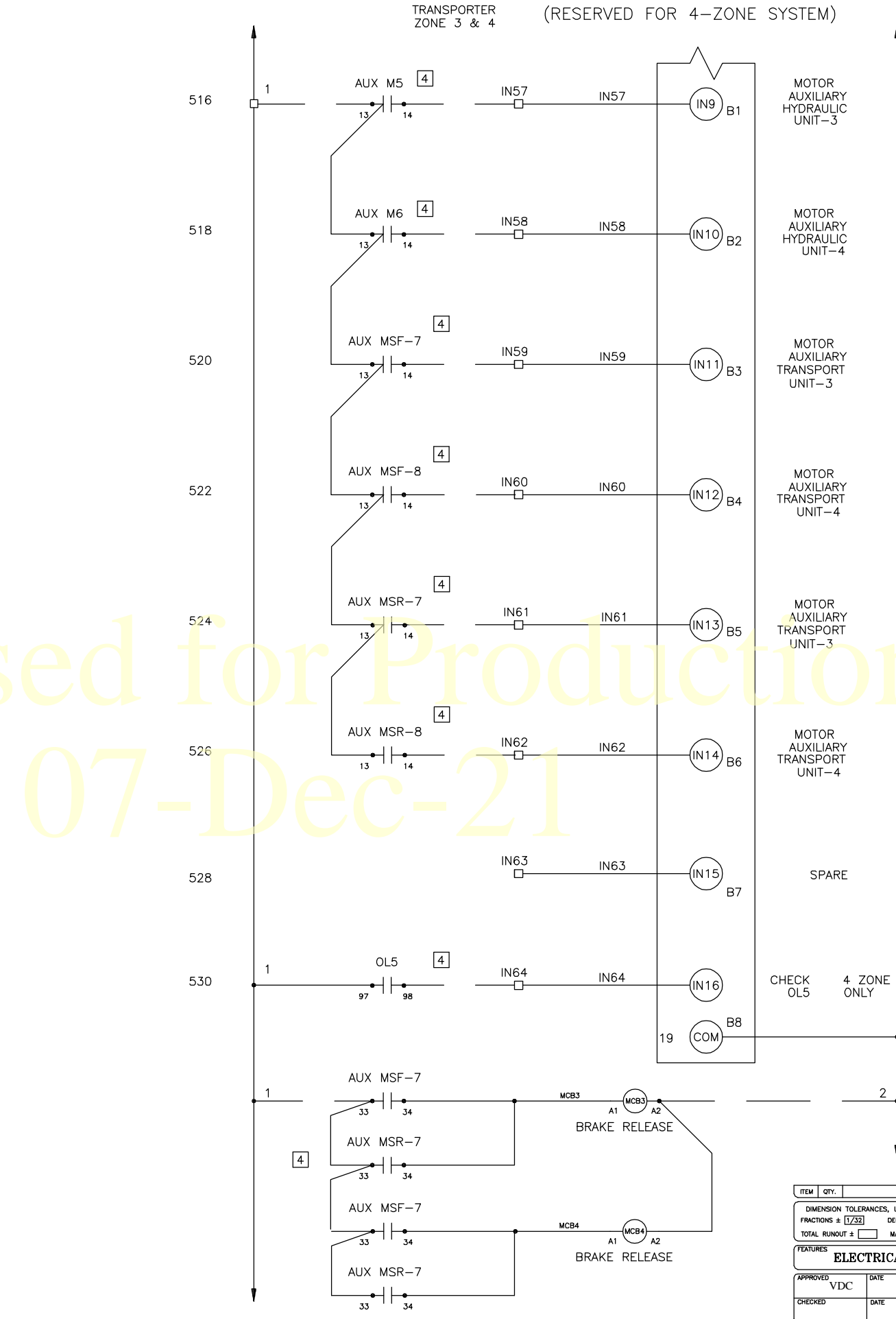
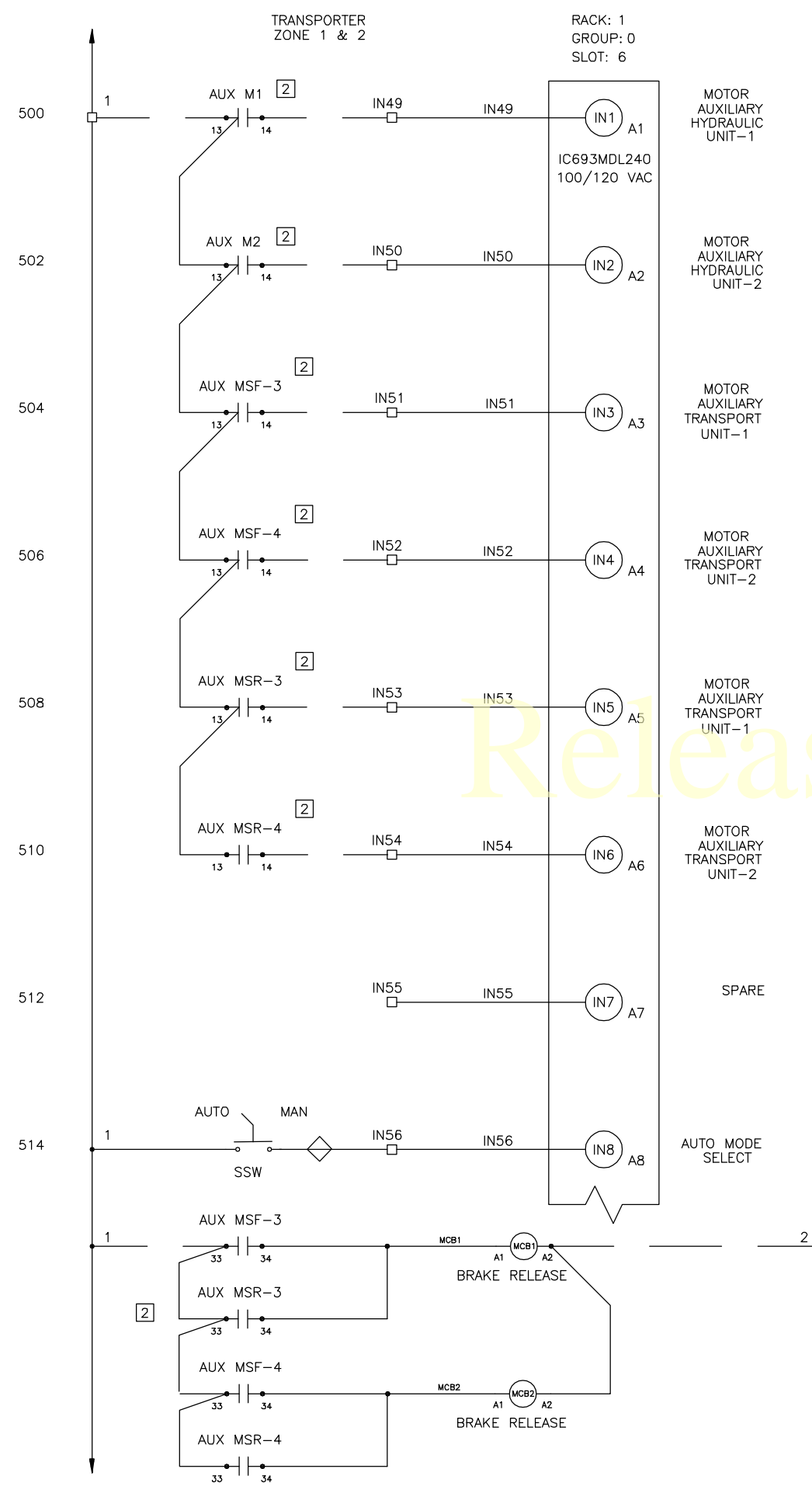

- 2 MOTOR CONTROL PANEL (2 ZONE)
- 4 MOTOR CONTROL PANEL (4 ZONE)
- ◇ PUSH BUTTON PANEL

ITEM	QTY.	PART NAME	MATERIAL AND/OR DESCRIPTION	LENGTH	CODE	DWG. NO./PART NO.
<small>DIMENSION TOLERANCES, UNLESS OTHERWISE SPECIFIED: FRACTIONS ± [1/32] DECIMALS ± [0.01] ANGLES ± [1°] TOTAL RUNOUT ± [] MACHINED SURFACES NOT SPECIFIED [79]</small>						
<small>THIS DRAWING AND/OR DATA SHEET, AND THE CONFIDENTIAL PROPRIETARY INFORMATION THEREON, IS PROPERTY OF MITEK INDUSTRIES, INC. AND IS NOT TO BE REPRODUCED OR COPIED IN WHOLE OR IN PART, OR USED FOR UNAUTHORIZED MANUFACTURING OR ANY OTHER EXPLOITATION OF THE ITEM DISCLOSED THEREIN, OR IN ANY OTHER WAY DISCLOSED OR USED FOR FURNISHING INFORMATION.</small>						
ELECTRICAL SCHEMATIC			MiTek Industries, Inc. 4203 SHORELINE DRIVE, EARTH CITY, MO. 63045			
APPROVED	VDC	DATE	MFG.	HORIZONTAL STACKER, 2/4-ZONE		
CHECKED	DATE	DRAWN	DATE	FINISH PAINT	SCALE	PAGE
		VCarroll	2/22/02	X	NONE	7 of 22
B90436						DASH NO. REV. G

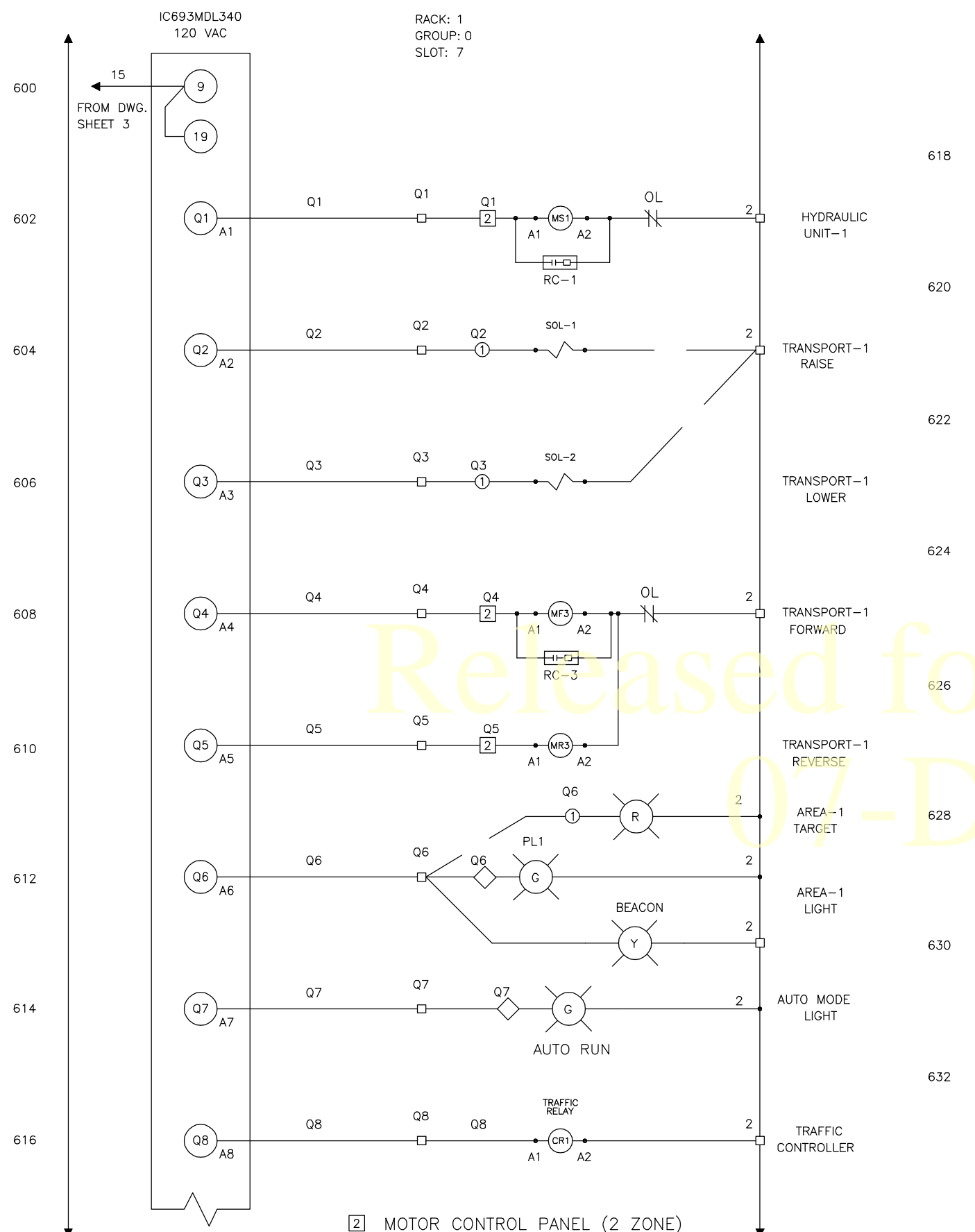

- ② MOTOR CONTROL PANEL (2 ZONE)
- ◇ PUSH BUTTON PANEL
- ① TRANSPORTER #1 J-BOX
- ② TRANSPORTER #2 J-BOX

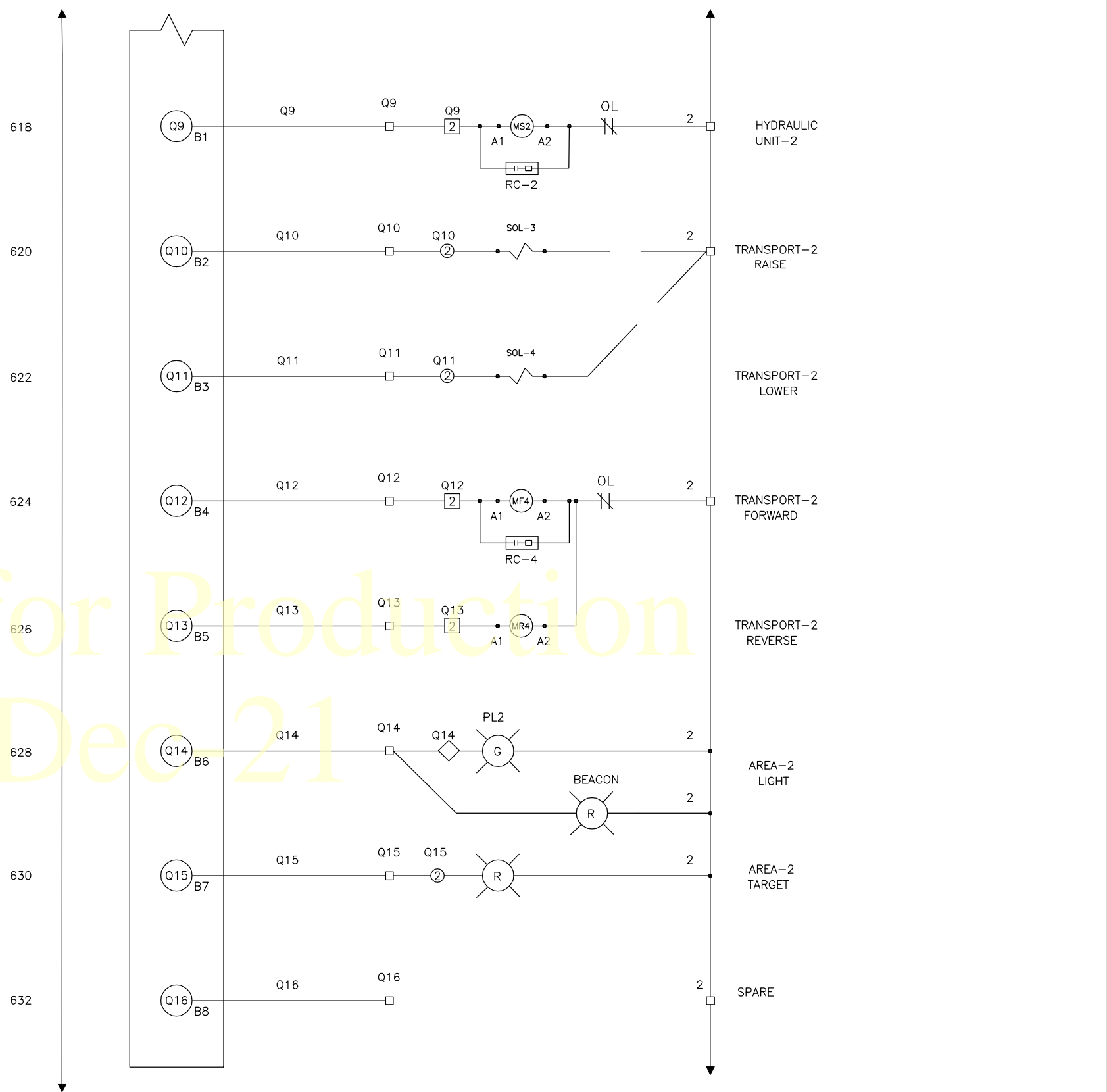

ITEM	QTY.	PART NAME	MATERIAL AND/OR DESCRIPTION	LENGTH	CODE	DWG. NO./PART NO.
<small>DIMENSION TOLERANCES, UNLESS OTHERWISE SPECIFIED: FRACTIONS ± [1/32] DECIMALS ± [0.01] ANGLES ± [1°] TOTAL RUNOUT ± [] MACHINED SURFACES NOT SPECIFIED []</small>						
<small>THIS DRAWING AND/OR DATA SHEET, AND THE CONFIDENTIAL PROPRIETARY INFORMATION THEREON, IS THE PROPERTY OF MITEK INDUSTRIES, INC. AND IS NOT TO BE REPRODUCED OR COPIED IN WHOLE OR IN PART, OR USED FOR UNAUTHORIZED MANUFACTURING OR ANY OTHER EXPLOITATION OF THE ITEM DISCLOSED THEREIN, OR IN ANY OTHER WAY DISCLOSED OR USED FOR FURNISHING INFORMATION.</small>						
FEATURES ELECTRICAL SCHEMATIC			MiTek Industries, Inc. 4203 SHORELINE DRIVE, EARTH CITY, MO. 63045			
APPROVED	VDC	DATE	MFG.	HORIZONTAL STACKER, 2/4-ZONE		
CHECKED	DATE	DRAWN	DATE	FINISH PAINT	SCALE	PAGE
		VCarroll	2/22/02	X	NONE	8 of 22
B90436						DASH NO. REV. G

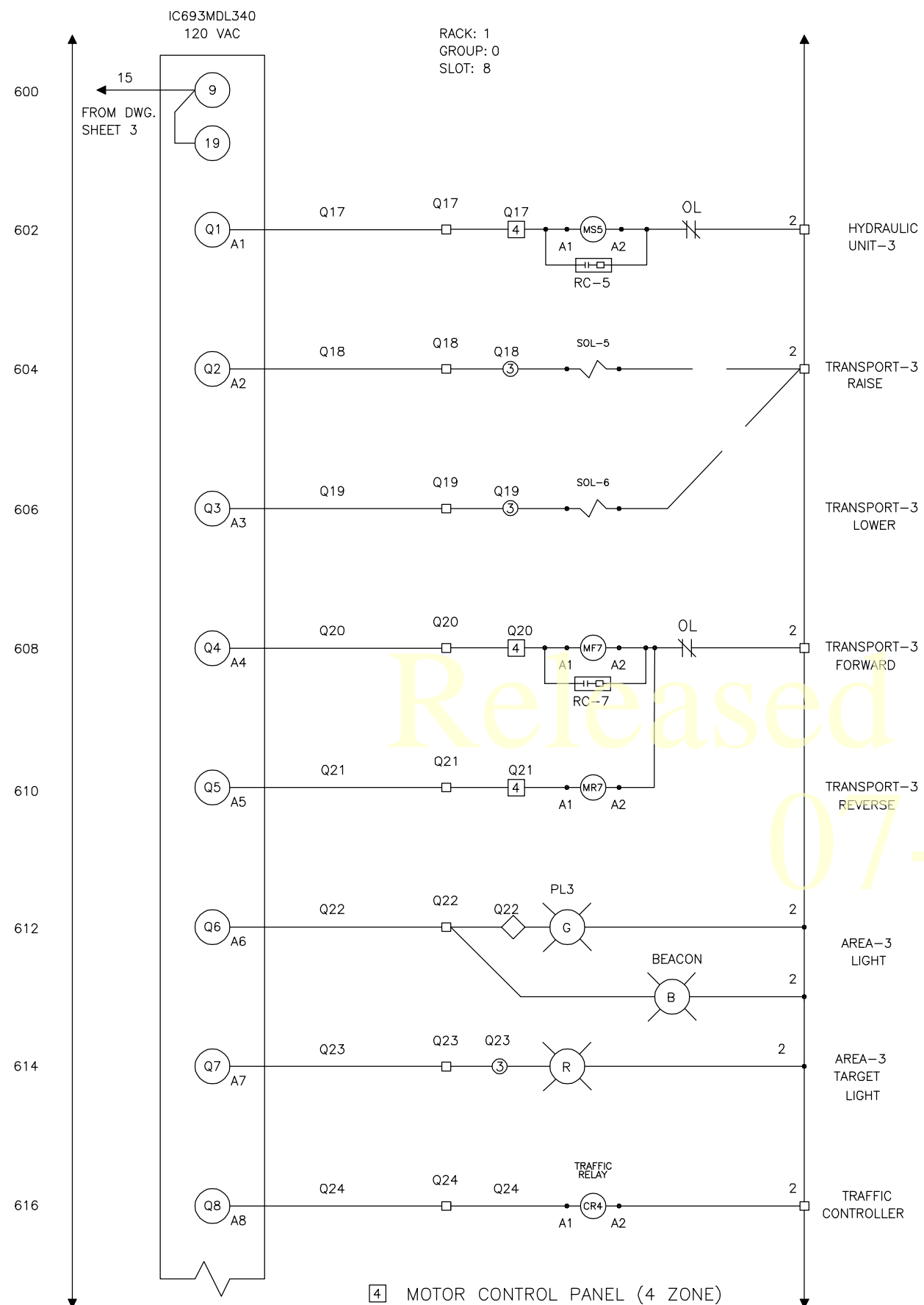

618

620

622

624

626

628

630

632

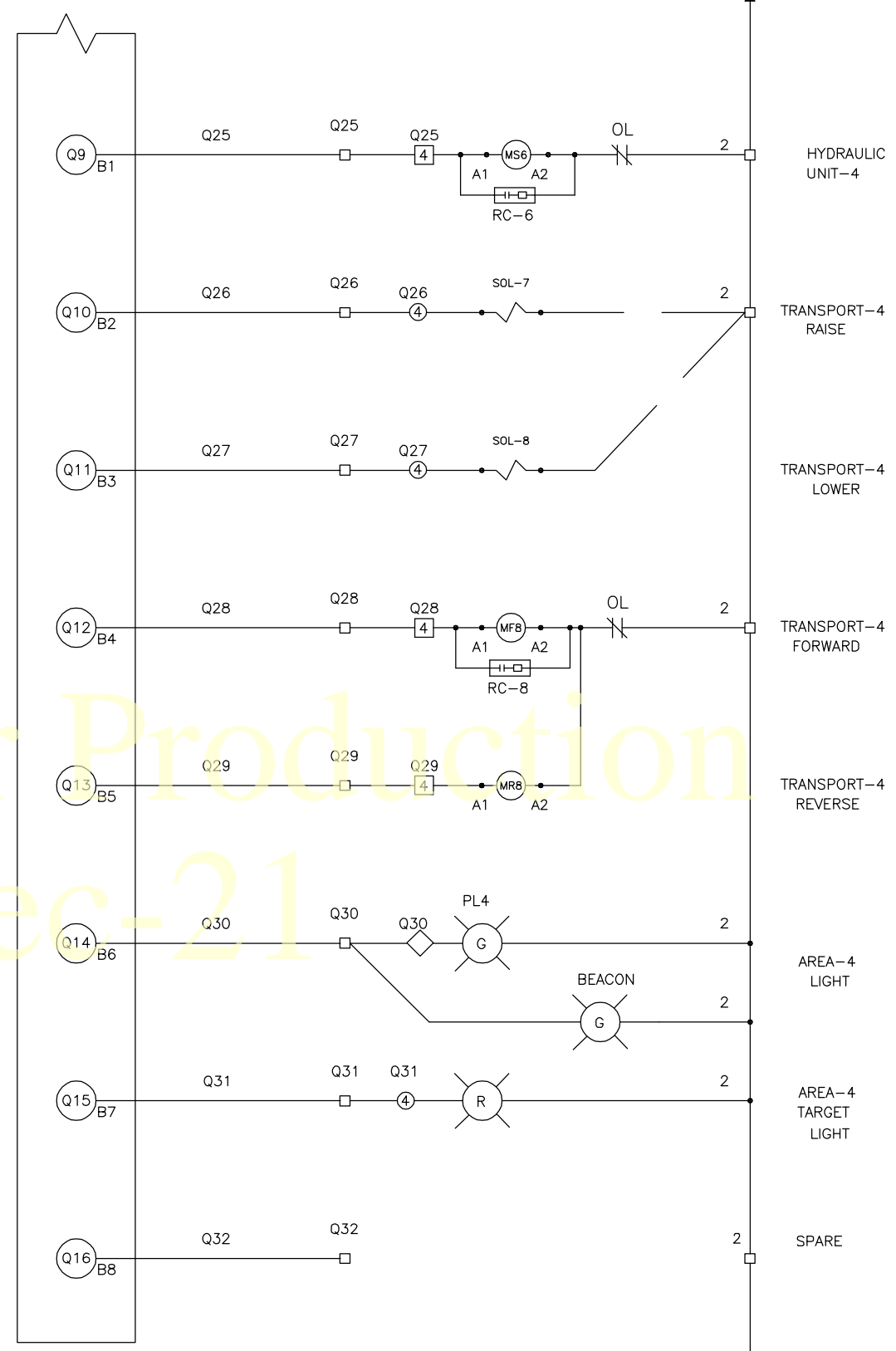

RESERVED WIRING
FOR 4-ZONE
SYSTEM

- ④ MOTOR CONTROL PANEL (4 ZONE)
- ◇ PUSH BUTTON PANEL
- ③ TRANSPORTER #3 J-BOX
- ④ TRANSPORTER #4 J-BOX

ITEM	QTY.	PART NAME	MATERIAL AND/OR DESCRIPTION	LENGTH	CODE	DWG. NO./PART NO.
<small>DIMENSION TOLERANCES, UNLESS OTHERWISE SPECIFIED: FRACTIONS ± [1/32] DECIMALS ± [0.01] ANGLES ± [1°]</small>						
<small>TOTAL RUNOUT ± [] MACHINED SURFACES NOT SPECIFIED []</small>						
<small>THIS DRAWING AND/OR DATA SHEET, AND THE CONFIDENTIAL PROPRIETARY INFORMATION THEREON, IS PROPERTY OF MITEK INDUSTRIES, INC. AND IS NOT TO BE REPRODUCED OR COPIED IN WHOLE OR IN PART, OR USED FOR UNAUTHORIZED MANUFACTURING OR ANY OTHER EXPLOITATION OF THE ITEM DISCLOSED THEREIN, OR IN ANY OTHER WAY DISCLOSED OR USED FOR FURNISHING INFORMATION.</small>						
FEATURES ELECTRICAL SCHEMATIC			MiTek Industries, Inc. 4203 SHORELINE DRIVE, EARTH CITY, MO. 63045			
APPROVED	VDC	DATE	MFG.	HORIZONTAL STACKER, 2/4-ZONE		
CHECKED	DATE	DRAWN	DATE	FINISH PAINT	SCALE	PAGE
		VCarroll	10/5/96	X	NONE	9 of 22
B90436						DASH NO. REV. G

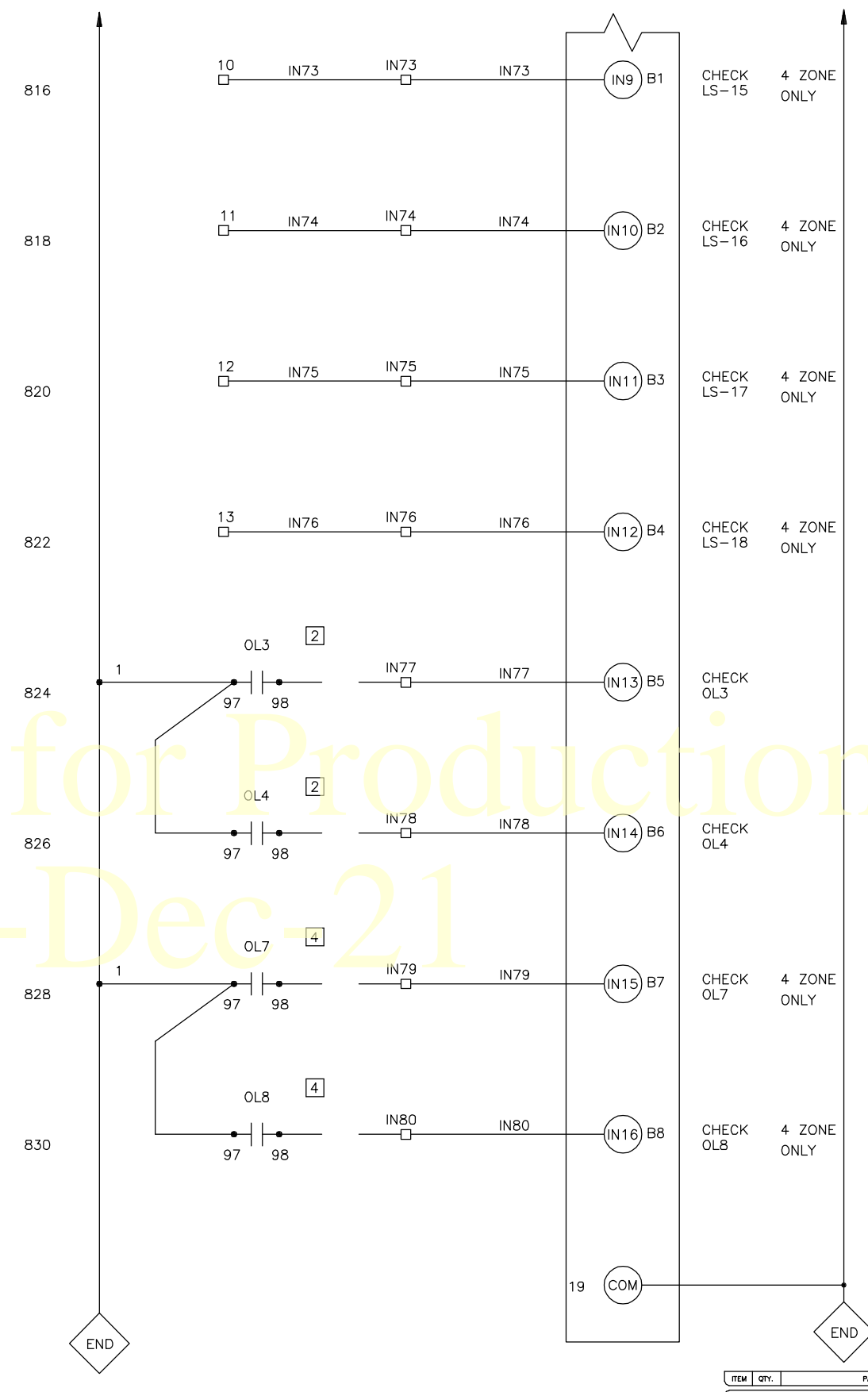
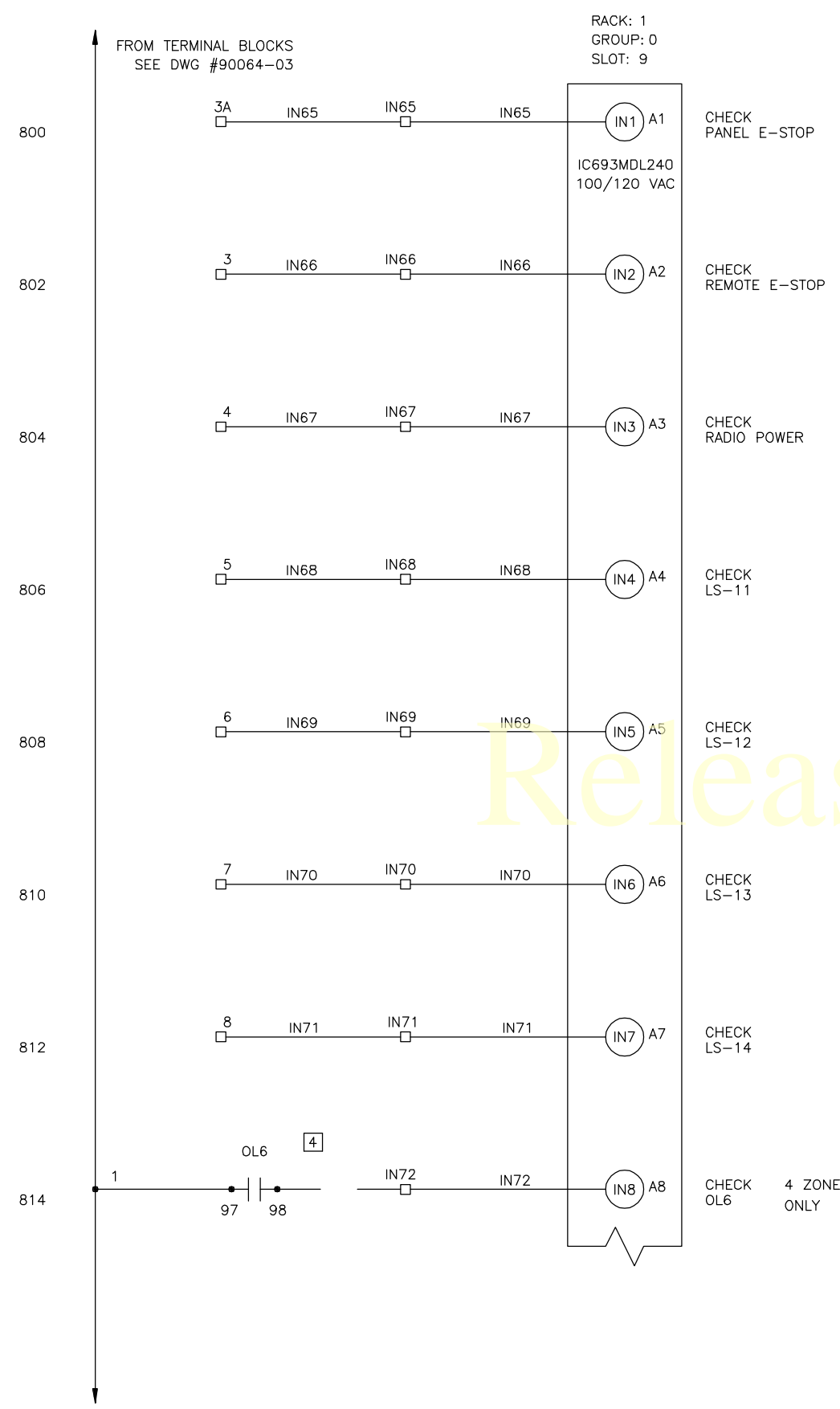

SYSTEM TROUBLESHOOTING:
ALL INPUTS ON THIS PAGE
SHOULD BE DESIGNATED
FOR SYSTEM VERIFICATION POINTS.

Released for Production
07-Dec-21

2 MOTOR CONTROL PANEL (2 ZONE)
4 MOTOR CONTROL PANEL (4 ZONE)

ITEM	QTY.	PART NAME	MATERIAL AND/OR DESCRIPTION	LENGTH	CODE	DWG. NO./PART NO.
<small>DIMENSION TOLERANCES, UNLESS OTHERWISE SPECIFIED: FRACTIONS ± [1/32] DECIMALS ± [0.01] ANGLES ± [1°] TOTAL RUNOUT ± [] MACHINED SURFACES NOT SPECIFIED [79]</small>						
<small>THIS DRAWING AND/OR DATA SHEET, AND THE CONFIDENTIAL PROPRIETARY INFORMATION THEREON, IS PROPERTY OF MITEK INDUSTRIES, INC. AND IS NOT TO BE REPRODUCED OR COPIED IN WHOLE OR IN PART, OR USED FOR UNAUTHORIZED MANUFACTURING OR ANY OTHER EXPLOITATION OF THE ITEM DISCLOSED THEREIN, OR IN ANY OTHER WAY DISCLOSED OR USED FOR FURNISHING INFORMATION.</small>						
FEATURES ELECTRICAL SCHEMATIC			MiTek Industries, Inc. 4203 SHORELINE DRIVE, EARTH CITY, MO. 63045			
APPROVED	VDC	DATE	MFG.	HORIZONTAL STACKER, 2/4-ZONE		
CHECKED	DATE	DRAWN	DATE	FINISH PAINT	SCALE	PAGE
		VCarroll	2/22/02	X	NONE	10 of 22
B90436						DASH NO. REV. G

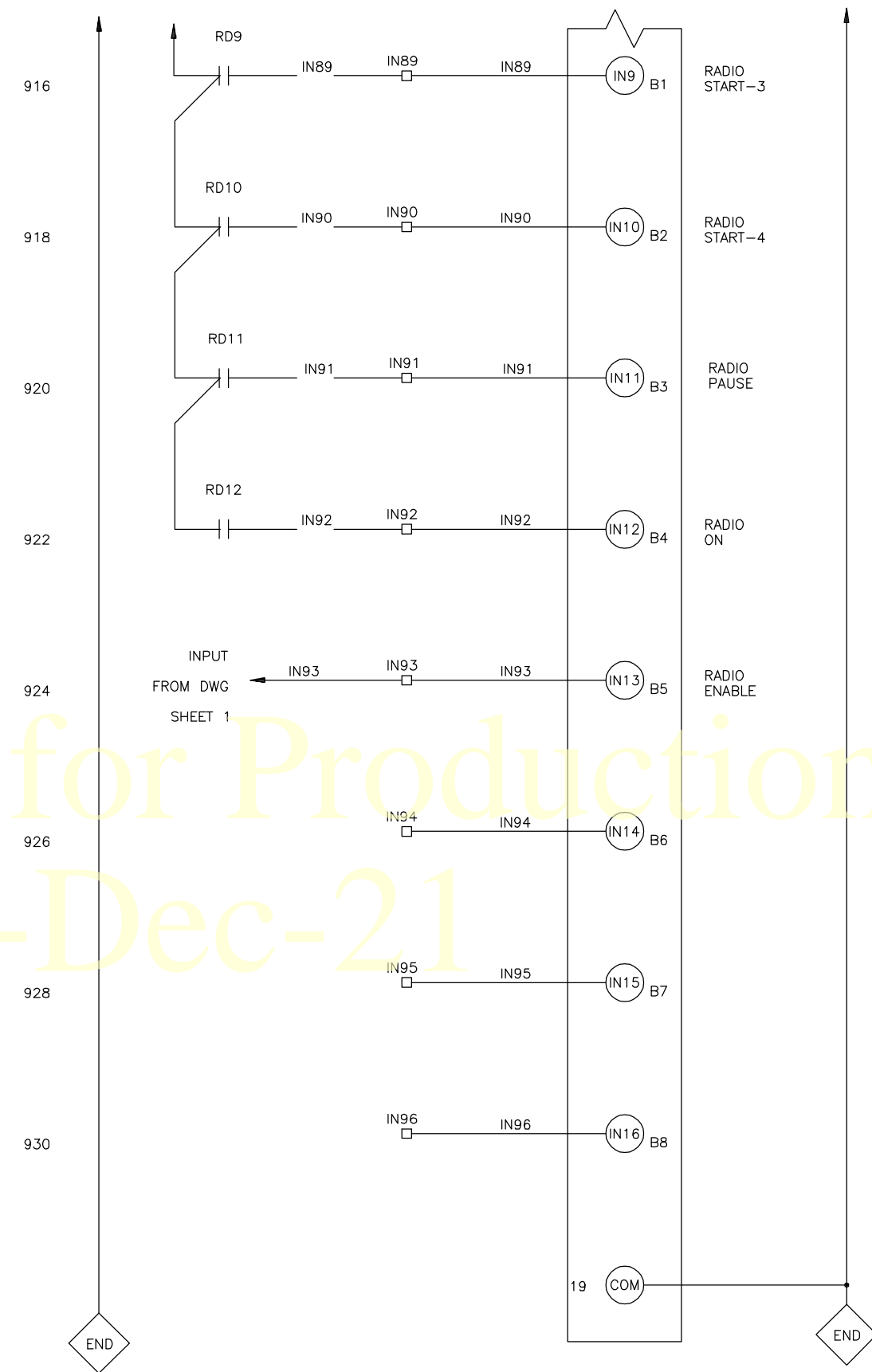
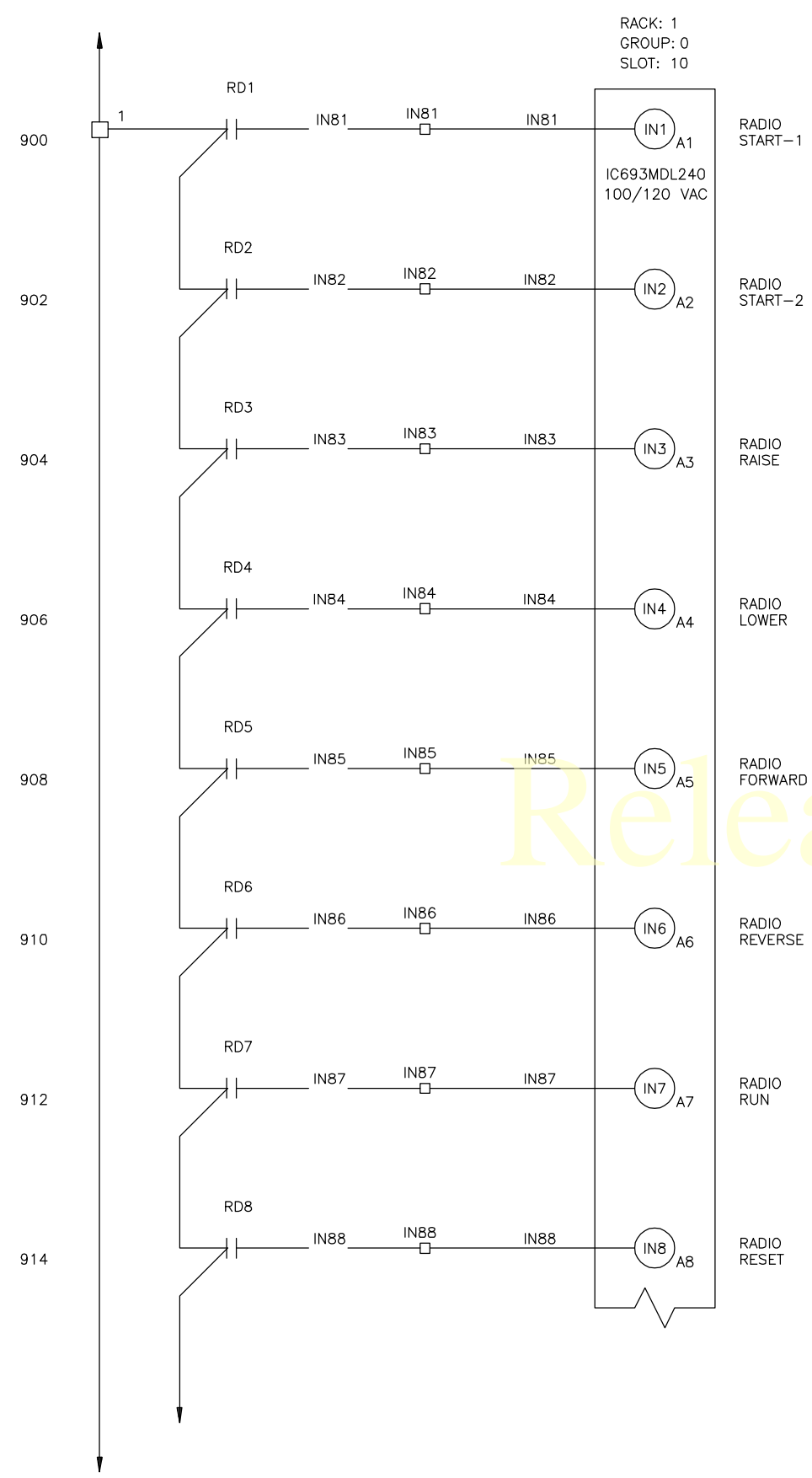

CABLE COLOR CODE
CHART FOR RADIO
WIRING SEE PG. 18

CABLE #508755
16awg
19 CONDUCTORS

Released for Production
07-Dec-21

OPTIONAL RADIO/RECEIVER PACKAGE

ITEM	QTY.	PART NAME	MATERIAL AND/OR DESCRIPTION	LENGTH	CODE	DWG. NO./PART NO.
DIMENSION TOLERANCES, UNLESS OTHERWISE SPECIFIED: FRACTIONS ± [1/32] DECIMALS ± [0.010] ANGLES ± [1°]						
TOTAL RUNOUT ± [] MACHINED SURFACES NOT SPECIFIED [29]						
FEATURES ELECTRICAL SCHEMATIC			MiTek Industries, Inc. 4203 SHORELINE DRIVE, EARTH CITY, MO. 63045			
APPROVED	VDC	DATE	MFG.	HORIZONTAL STACKER, 2/4-ZONE		
CHECKED	DATE	DRAWN	DATE	FINISH PAINT	SCALE	PAGE
		VCarroll	2/22/02	X	NONE	11 of 22
B90436						DASH NO. REV. G

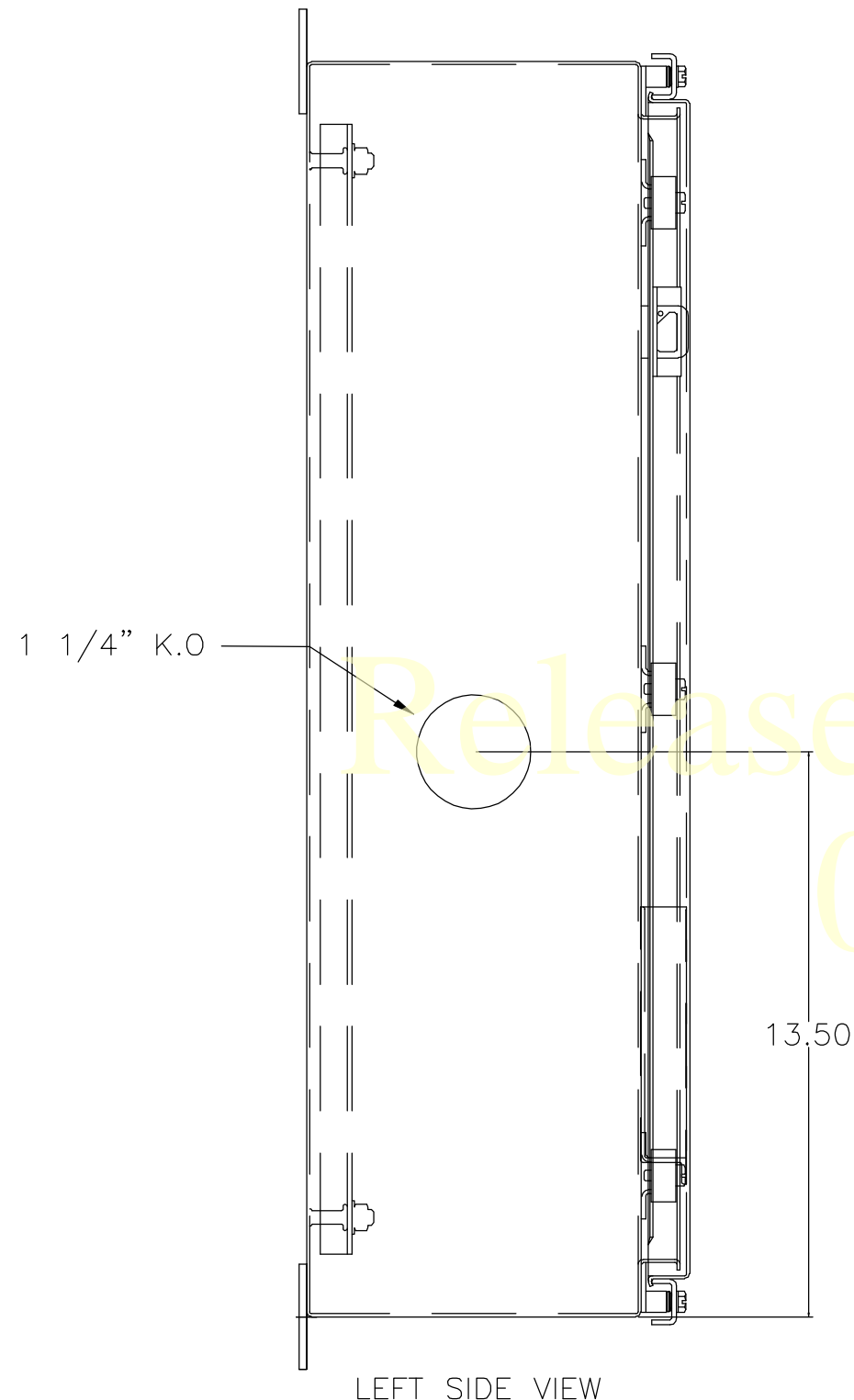

LEFT SIDE VIEW

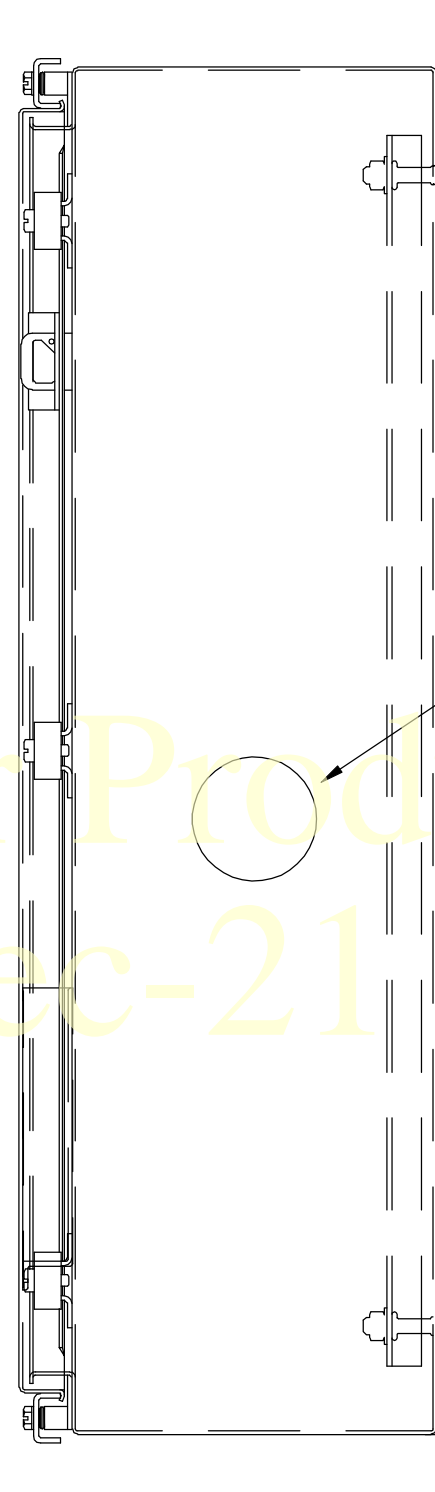

RIGHT SIDE VIEW

NOTE: (SEE BOM 90436-501)
 INSTALL THE HOLE PLUG ITEM #7 ON
 THE SIDE NOT USED FOR
 WIRING/CONDUIT CONNECTION TO MAIN
 PLC ENCLOSURE. WHEN BUILDING A 2
 ZONE SYSTEM.

Released for Production
 07-Dec-21

ITEM	QTY.	PART NAME	MATERIAL AND/ OR DESCRIPTION	LENGTH	CODE	DWG.NO./PART NO.
DIMENSION TOLERANCES, UNLESS OTHERWISE SPECIFIED: FRACTIONS ± [1/32] DECIMALS ± [0.01] ANGLES ± [1°] TOTAL RUNOUT ± [0.004] MACHINED SURFACES NOT SPECIFIED [25]						
THIS DRAWING AND/OR DATA SHEET, AND THE CONFIDENTIAL PROPRIETARY INFORMATION THEREON, IS PROPERTY OF MITEK INDUSTRIES, INC. AND IS NOT TO BE REPRODUCED OR COPIED IN WHOLE OR IN PART, OR USED FOR UNAUTHORIZED MANUFACTURING OR ANY OTHER EXPLOITATION OF THE ITEM DISCLOSED THEREIN, OR IN ANY OTHER WAY DISCLOSED OR USED FOR FURNISHING INFORMATION.						
FEATURES MOTOR PANEL LAYOUT			MiTek Industries, Inc. 4203 SHORELINE DRIVE, EARTH CITY, MO. 63045			
APPROVED	VDC	DATE	MFG.	HORIZONTAL STACKER, 2/4-ZONE		
CHECKED		DATE	DRAWN	DATE	FINISH PAINT	SCALE
			VCarroll	2/22/02	X	NONE
				PAGE	12 of 22	DASH NO. REV.
					B90436	502 G

MOTOR PANEL LAYOUT

REV.	DATE	DESCRIPTION	BY	CHK'D	APP'D	DATE
------	------	-------------	----	-------	-------	------

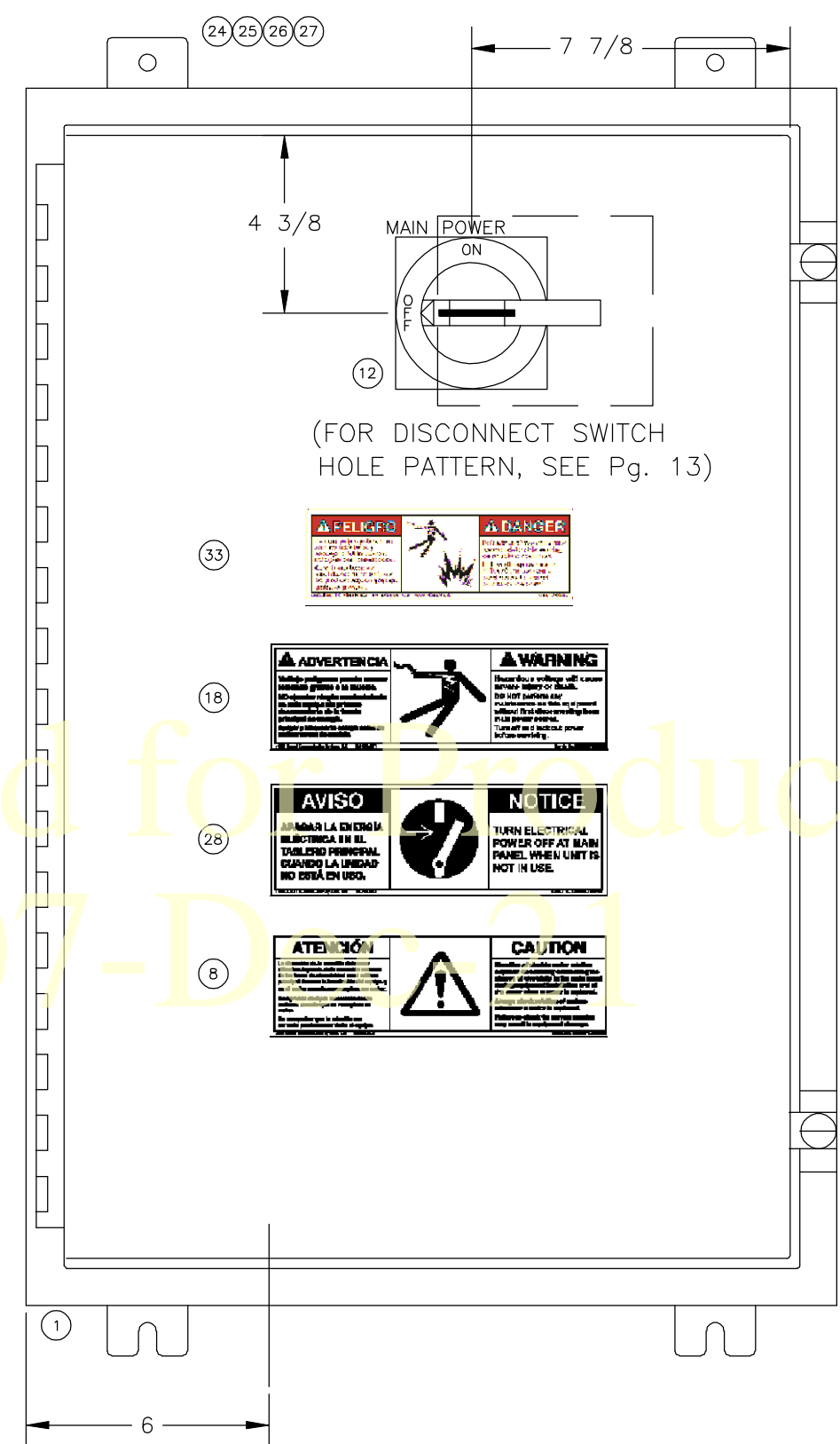
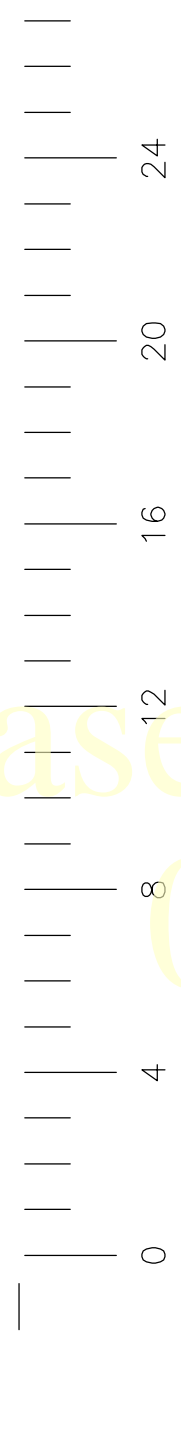
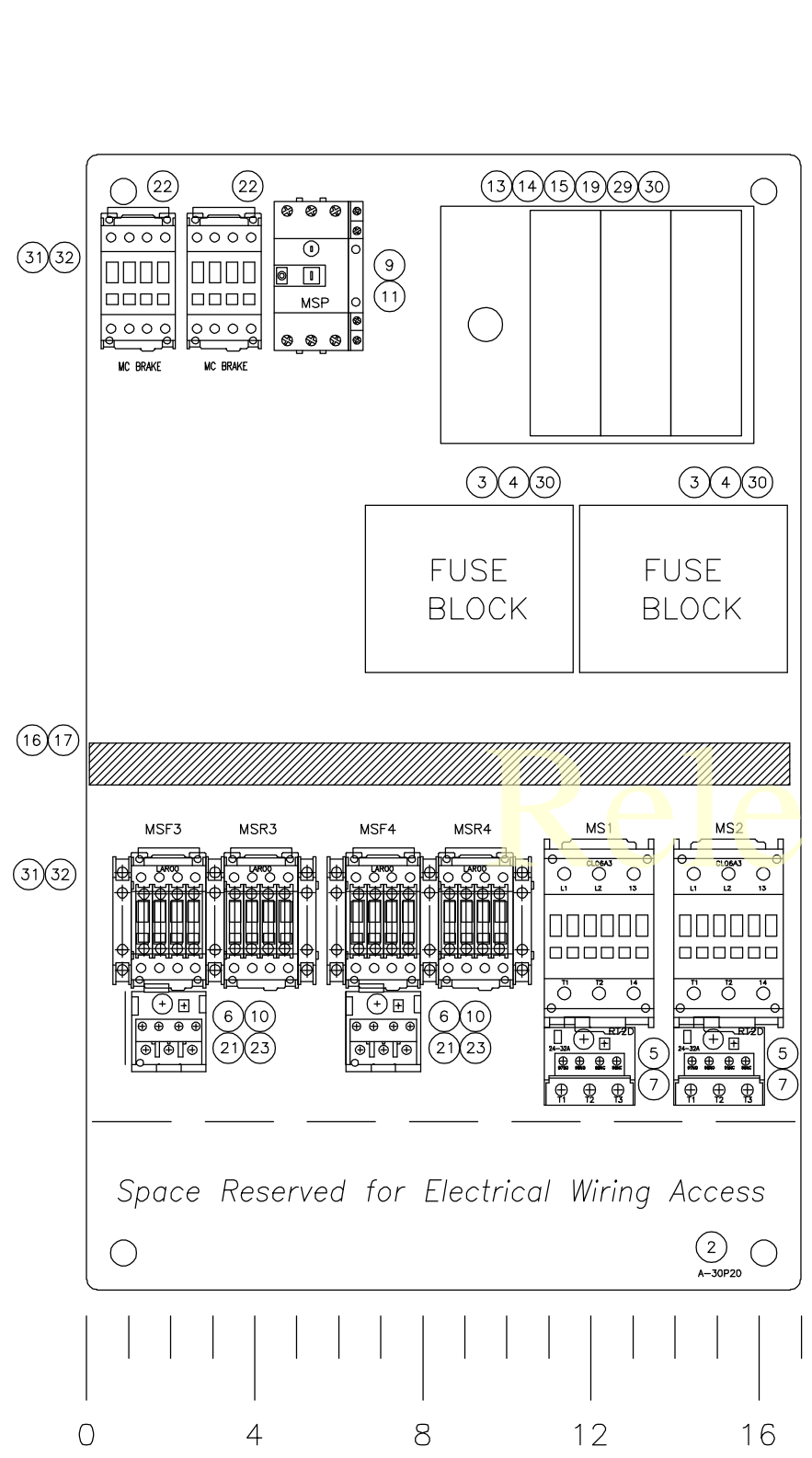

ITEM	QTY.	PART NAME	MATERIAL AND/ OR DESCRIPTION	LENGTH	CODE	DWG. NO./PART NO.
33	1 EA	LABEL-DANGER-ARC FLASH	HCS #5022301C	X	P	691411
32	2 FT	RAIL,DIN	IDEC #BNDN-1000	X	P	146122
31	6 EA	RIVET-POP 5/32	#ABA53(EXP)	X	P	390005
30	8 EA	SCW,RDHD,SL	10-32X3/8(CF)	DISC/FUSEBLK	P	341103
29	4 EA	WSHR,FLT	#10	DISC	P	365109
28	1 EA	LABEL-NOTICE TURN ELEC.	HCS #BSMH6058-746NHBS	X	P	691701
27	4 EA	NUT,HEX,FINISHED	3/8-16	X	P	361605
26	4 EA	WSHR,LCK,SAE	3/8	X	P	364042
25	4 EA	WSHR,FLT,SAE	3/8	X	P	365123
24	4 EA	C'SCW,HXHD	3/8-16x1-3/4	X	P	327267
23	4 EA	SURGE SUPPRESSOR, RC, 50-127VAC	GE #BSLR2K	X	P	509226
22	2 EA	MTR-STARTER,10A,3-P,NON-RE	GE #CLO0A310TJ	X	P	509211
21	4 EA	CONTACT,AUX,BASE-BLK,2NO	GE #BCLL20	X	P	514190
20	3 EA	DISC,FUSE,REDUCER,100A,600V	BUSSMAN#J-16	460V	P	509440
19	1 EA	DISC,SWITCH,LUG KIT,100A,600V	BUSSMANN #BDTL24	X	P	509439
18	1 EA	LABEL-WARNING HAZARDOUS	HCS #BSM5025-742WHBS	X	P	691507
17	2 FT	COVER,DUCT,WIRING,PVC	PANDUIT #C1 LG6	X	P	510151
16	2 FT	WIRING,DUCT,PVC	PANDUIT #G1 x 3LG6	X	P	510141
15	3 EA	FUSE,70A,SP	BUSSMAN #LPJ-70 SP	230V/208V	P	516498
15	3 EA	FUSE,LOW PEAK,35 A	BUSSMAN #LPJ-35SP	460V	P	477058
14	1 EA	DISC,SWITCH,100A,600V	BUSSMANN #CFD100J3	X	P	509436
13	1 EA	DISC,SHAFT,11.4",0.24x0.24"	BUSSMANN #BDS290	X	P	509437
12	1 EA	DISC,HANDLE,100A,3.15",BLACK	BUSSMANN #BDH60	X	P	509438
11	1 EA	MSP,AUX,CONTACT,1N.O./1N.C.	SURION #GPAC11LLA	X	P	509261
10	2 EA	RELAY,OVERLOAD,1.8-2.7A,AUTO/MAN	GE #RT1J	230V/208V	P	514146
10	2 EA	RELAY,OVERLOAD,1.0-1.5A,AUTO/MAN	GE #RT1G	460V	P	514142
9	1 EA	MSP,6.3-10A	SURION #GPS1BSAK	230V/208V	P	509267
9	1 EA	MSP,2.5-4A	SURION #GPS1BSAH	460V	P	509265
8	1 EA	LABEL-CAUTION	HCS #BSMH6014-B38EHBS	X	P	691603
7	2 EA	OVERLOAD,24-32A,AUTO/MAN	GE #RT2D	230V/208V	P	514176
7	2 EA	RELAY,OVERLOAD,10-16A,AUTO/MAN	GE #RT1P	460V	P	514156
6	2 EA	MOTOR,STARTER,9A,REVERSING	GE #LAR00AJ	X	P	509210
5	2 EA	MTR,STARTER,48A,3P,NON-REV	GE #CLO6A311MJ	230V/208V	P	509223
5	2 EA	MTR,STARTER,22A,3P,NON-REV	GE #CL25A310TJ	460V	P	509217
4	6 EA	FUSE,LOW PEAK,40A	BUSSMAN #LPJ-40SP	230V/208V	P	477075
4	6 EA	FUSE,LOW PEAK,20A	BUSSMAN #LPJ-20SP	460V	P	516490
3	2 EA	BLOCK-FUSE	BUSSMAN #JP60030-3CR	460V	P	516504
3	2 EA	BLOCK-FUSE	BUSSMAN #J60060-3C	230V/208V	P	477059
2	1 EA	PANEL	HOFFMAN #A-30P20	X	P	519627
1	1 EA	ENCLOSURE,NEMA4	HOFFMAN #A-30H20BLP	519626	M	90436-102

NOTE: 1 PANEL FOR EACH 2-ZONE AREA.
(EX: 4-ZONE STACKER WILL HAVE 2 MOTOR BOXES. 1 MOUNTED FOR EACH 2 STRUCTURES.)

1-1/4"K.O.(ø1-11/16"DRILL)
CENTER HOLE ON BOTTOM WIDTH

DIMENSION TOLERANCES, UNLESS OTHERWISE SPECIFIED:
FRACTIONS ± [1/32] DECIMALS ± [0.01] ANGLES ± [1°]

TOTAL RUNOUT ± [] MACHINED SURFACES NOT SPECIFIED [20°]

THIS DRAWING AND/OR DATA SHEET, AND THE CONFIDENTIAL PROPRIETARY INFORMATION THEREON, IS THE PROPERTY OF MITEK INDUSTRIES, INC. AND IS NOT TO BE REPRODUCED OR COPIED IN WHOLE OR IN PART, OR USED FOR UNAUTHORIZED MANUFACTURING OR ANY OTHER EXPLOITATION OF THE ITEM DISCLOSED THEREIN, OR IN ANY OTHER WAY DISCLOSED OR USED FOR FURNISHING INFORMATION.

FEATURES: MOTOR PANEL LAYOUT

APPROVED: VDC DATE: MFG. HORIZONTAL STACKER, 2/4-ZONE

CHECKED: DATE: DRAWN: VCarroll DATE: FINISH PAINT: X SCALE: NONE PAGE: 13 OF 22 DASH NO.: B90436 REV. 502 G

MiTek Industries, Inc.
4203 SHORELINE DRIVE, EARTH CITY, MO. 63045

PANEL #3

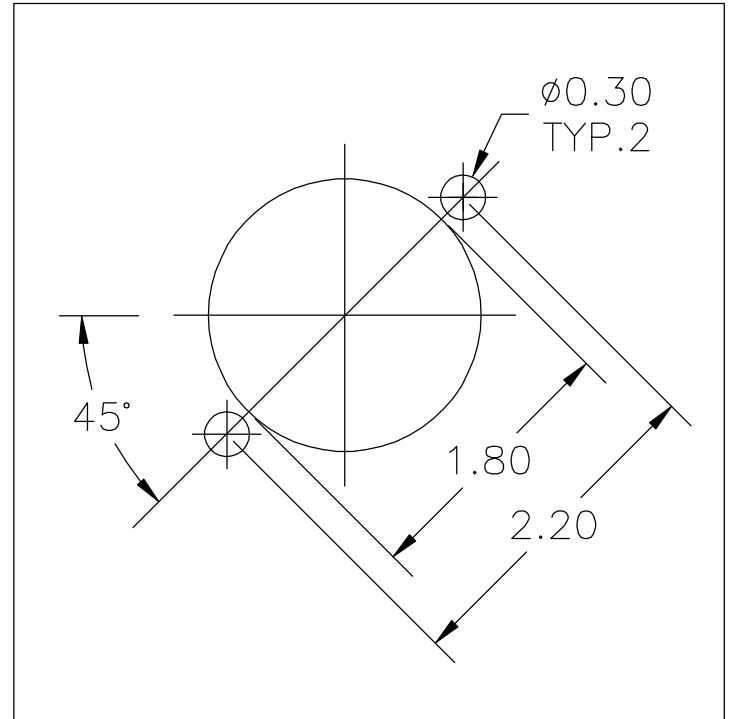
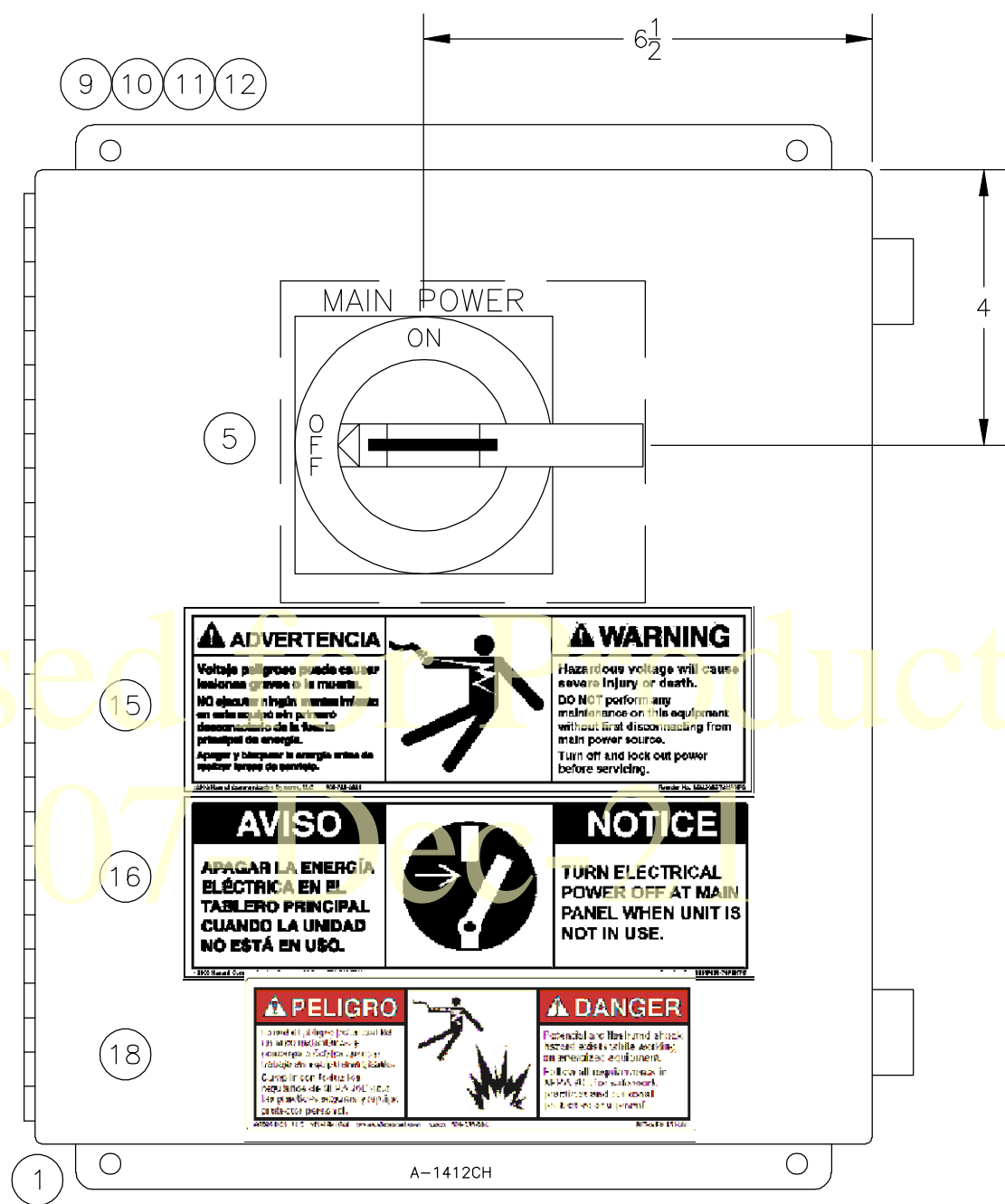
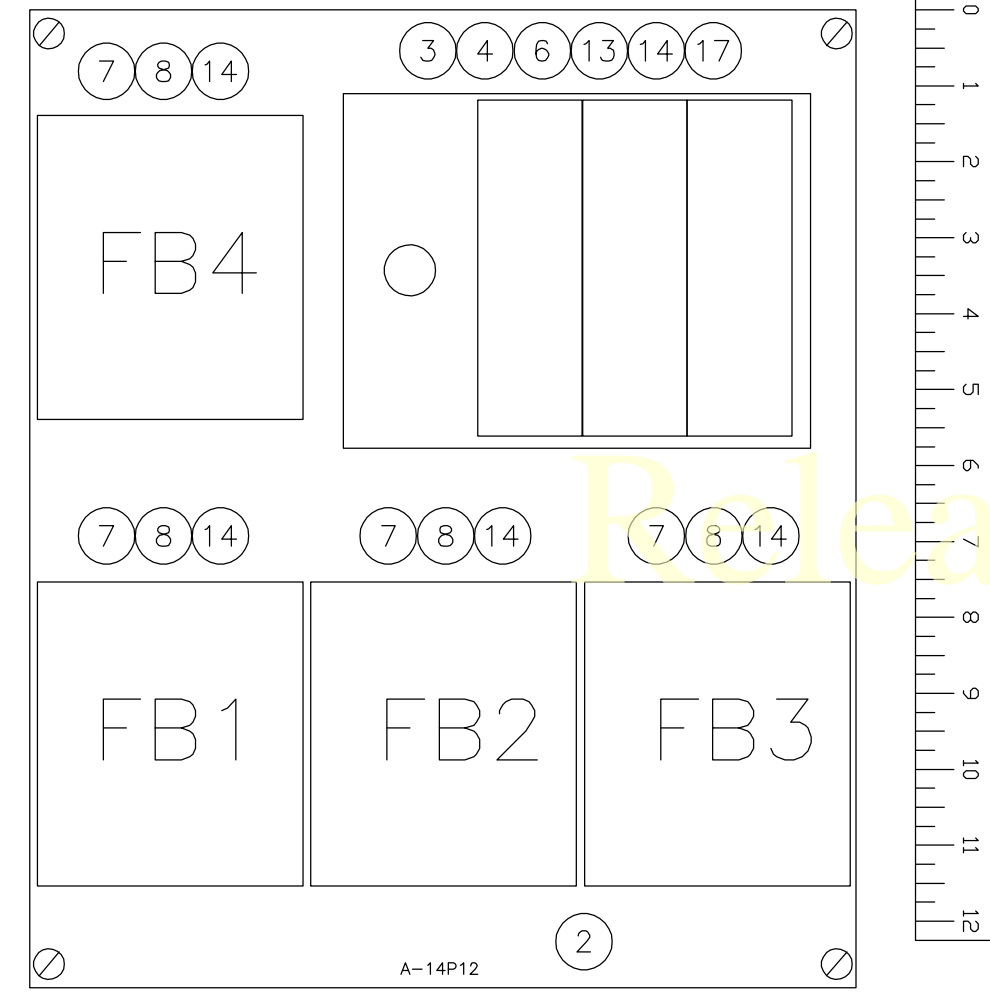
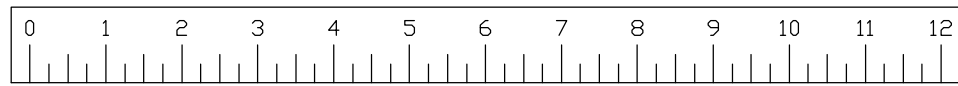

DISCONNECT SWITCH HOLE PATTERN

ADVERTENCIA

Voltaje peligroso puede causar lesiones graves o la muerte. NO ejecutar ningún trabajo eléctrico en esta unidad sin primero desconectarla de la fuente principal de energía. Apagar y bloquear la energía antes de realizar trabajo de servicio.

WARNING

Hazardous voltage will cause severe injury or death. DO NOT perform any maintenance on this equipment without first disconnecting from main power source. Turn off and lock out power before servicing.

AVISO

APAGAR LA ENERGÍA ELÉCTRICA EN EL TABLERO PRINCIPAL CUANDO LA UNIDAD NO ESTÁ EN USO.

NOTICE

TURN ELECTRICAL POWER OFF AT MAIN PANEL WHEN UNIT IS NOT IN USE.

PELIGRO

El voltaje peligroso puede causar lesiones graves o la muerte. No ejecutar ningún trabajo eléctrico en esta unidad sin primero desconectarla de la fuente principal de energía. Apagar y bloquear la energía antes de realizar trabajo de servicio.

DANGER

Hazardous voltage will cause severe injury or death. Do not perform any maintenance on this equipment without first disconnecting from main power source. Turn off and lock out power before servicing.

Hydraulic Heater Panel

ITEM	QTY.	PART NAME	MATERIAL AND/OR DESCRIPTION	LENGTH	CODE	DWG. NO./PART NO.
18	1 EA	LABEL-DANGER-ARC FLASH	HCS #5022301C	X	P	691411
17	3 EA	DISC,FUSE,REDUCER,30A/60A	BUSSMAN #J-63	460V	P	509441
16	1 EA	LABEL-NOTICE TURN ELEC.	HCS #BSMH6058-746NHBS	X	P	691701
15	1 EA	LABEL-WARNING HAZARDOUS	HCS #BSM5025-742WHBS	X	P	691507
14	1 EA	SCW,RDHD,SL	10-32x3/8	DISC/FUSEBLK	P	341103
13	4 EA	WSHR,FLT	#10	DISC	P	365109
12	4 EA	NUT,HEX,FINISHED	1/4-20	X	P	361601
11	4 EA	WSHR,LCK,TYP.M	1/4	X	P	364034
10	4 EA	WSHR,FLT,SAE,TYP.A,N	1/4x5/8x.049	X	P	365115
9	4 EA	C'SCW,HXHD,GR.5	1/4-20x3/4	X	P	327157
8	8 EA	FUSE,15A	BUSSMANN #LPJ-15 SP	X	P	516489
7	4 EA	FUSE BLOCK,TYPE J,2-PL,30A	BUSSMANN #J60030-2C	X	P	516502
6	3 EA	FUSE,30A	BUSSMAN #LPJ-30SP	460V	P	516492
6	3 EA	FUSE,50A,600V,TYPE-J	BUSSMAN #LPJ-50SP	230V/208V	P	516494
5	1 EA	DISC,HANDLE,OFF/ON,3.1	BUSSMANN #BDH60	X	P	509438
4	1 EA	DISC,SHAFT,5.9,.24x.24	BUSSMANN #BDS150	X	P	509424
3	1 EA	DISC,SWITCH,60A,FUSED	BUSSMANN #CFD60J3	X	P	509429
2	1 EA	PANEL	HOFFMAN #A-14P12	X	P	519071
1	1 EA	ENCLOSURE,14x12x6	HOFFMAN #A-1412CHNF	519040	M	90436-103

DIMENSION TOLERANCES, UNLESS OTHERWISE SPECIFIED:
 FRACTIONS ± [1/32] DECIMALS ± [0.01] ANGLES ± [1°]
 TOTAL RUNOUT ± [] MACHINED SURFACES NOT SPECIFIED [79°]

THIS DRAWING AND/OR DATA SHEET, AND THE CONFIDENTIAL PROPRIETARY INFORMATION THEREON, IS THE PROPERTY OF MITEK INDUSTRIES, INC. AND IS NOT TO BE REPRODUCED OR COPIED IN WHOLE OR IN PART, OR USED FOR UNAUTHORIZED MANUFACTURING OR ANY OTHER EXPLOITATION OF THE ITEM DISCLOSED THEREIN, OR IN ANY OTHER WAY DISCLOSED OR USED FOR FURNISHING INFORMATION.

FEATURES: HEATER PANEL LAYOUT

MiTek Industries, Inc.
 4203 SHORELINE DRIVE, EARTH CITY, MO. 63045

APPROVED: VDC DATE: MFG. DATE: FINISH PAINT: SCALE: PAGE: 14 OF 22
 CHECKED: DATE: DRAWN: VCarroll DATE: FINISH PAINT: SCALE: NONE PAGE: B90436 DASH NO.: 503 REV.: G

PLC CONTROL PANEL LAYOUT

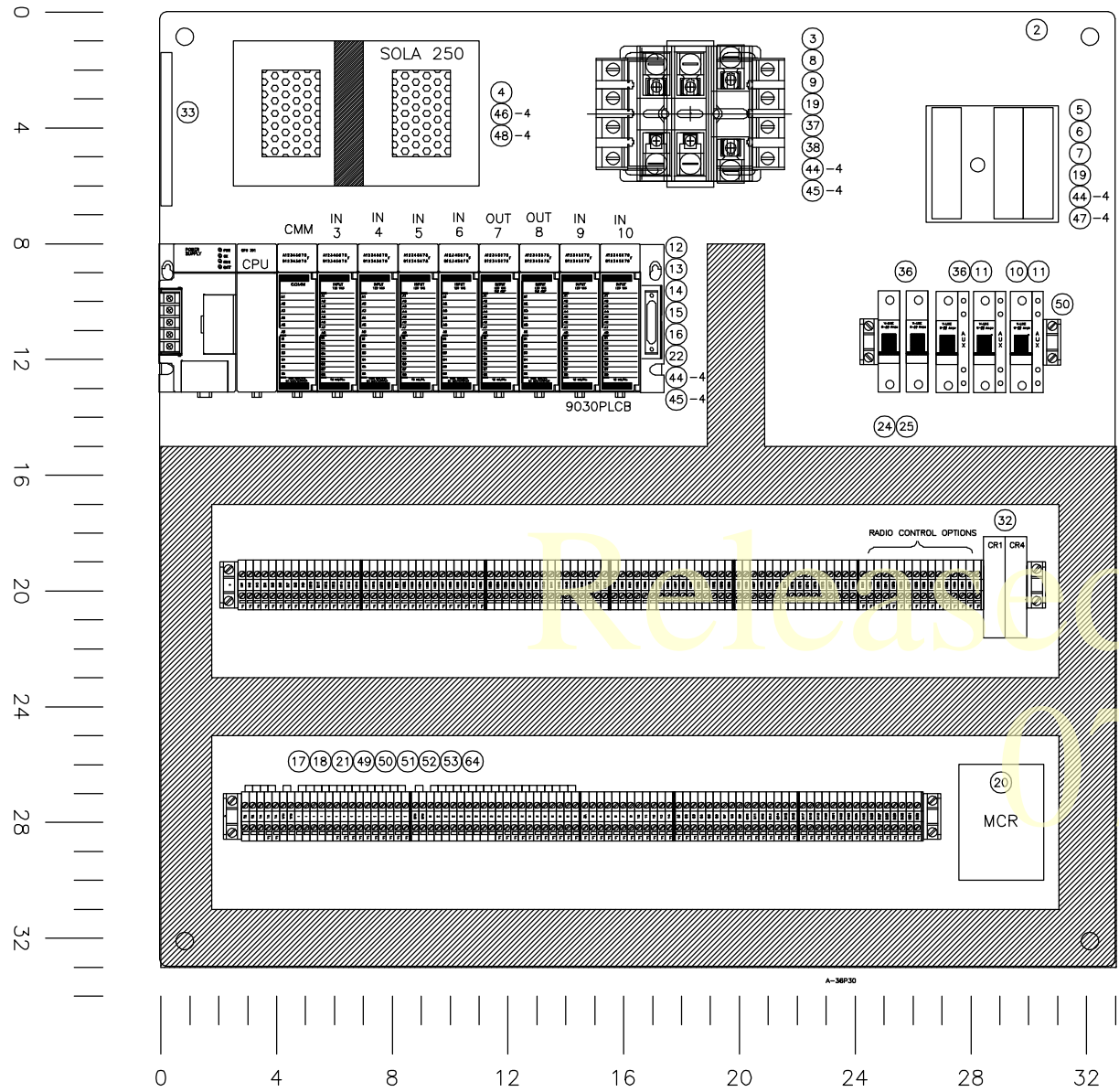

TO PUSHBUTTON PANEL
SEE HOLE DETAILS ON
PAGE 16

PLC CONTROL PANEL

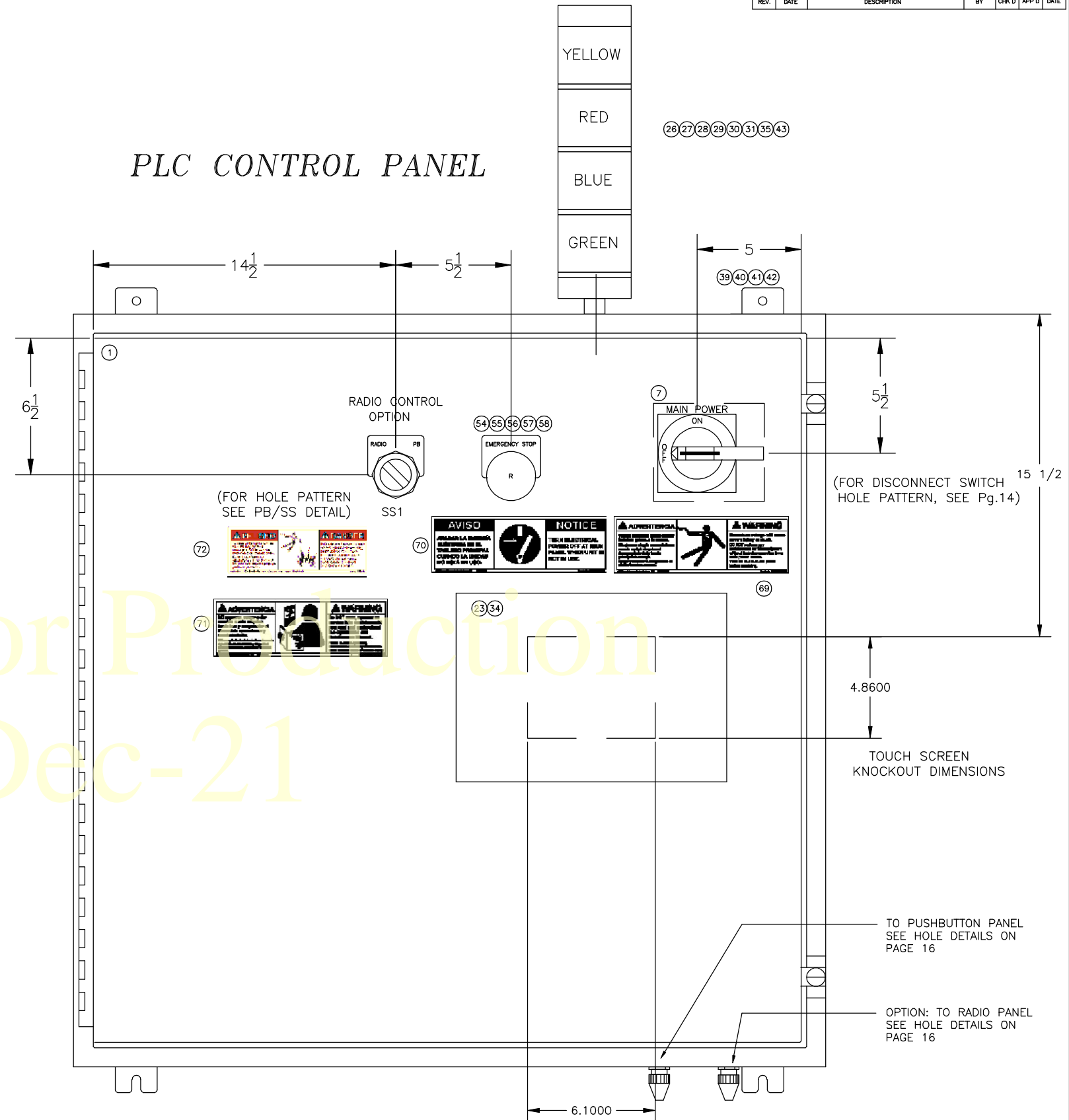

(FOR DISCONNECT SWITCH
HOLE PATTERN, SEE Pg.14)

TOUCH SCREEN
KNOCKOUT DIMENSIONS

TO PUSHBUTTON PANEL
SEE HOLE DETAILS ON
PAGE 16

OPTION: TO RADIO PANEL
SEE HOLE DETAILS ON
PAGE 16

ITEM	QTY.	PART NAME	MATERIAL AND/OR DESCRIPTION	LENGTH	CODE	DWG. NO./PART NO.
<small>DIMENSION TOLERANCES, UNLESS OTHERWISE SPECIFIED: FRACTIONS ± [1/32] DECIMALS ± [0.010] ANGLES ± [1°] TOTAL RUNOUT ± [] MACHINED SURFACES NOT SPECIFIED [79°]</small>						
<small>*THIS DRAWING AND/OR DATA SHEET, AND THE CONFIDENTIAL PROPRIETARY INFORMATION THEREON, IS THE PROPERTY OF MITEK INDUSTRIES, INC. AND IS NOT TO BE REPRODUCED OR COPIED IN WHOLE OR IN PART, OR USED FOR UNAUTHORIZED MANUFACTURING OR ANY OTHER EXPLOITATION OF THE ITEM DISCLOSED THEREIN, OR IN ANY OTHER WAY DISCLOSED OR USED FOR FURNISHING INFORMATION.*</small>						
CONTROL PANEL LAYOUT			MiTek Industries, Inc. 4203 SHORELINE DRIVE, EARTH CITY, MO. 63045		PAGE X OF X	
APPROVED	VDC	DATE	MFG.	HORIZONTAL STACKER, 2/4-ZONE		
CHECKED	DATE	DRAWN	DATE	FINISH PAINT	SCALE	PAGE
		VCarroll	2/22/02	X	NONE	15 of 22
B90436					DASH NO.	REV.
501					G	

(PARTS LIST ON PAGE 16)

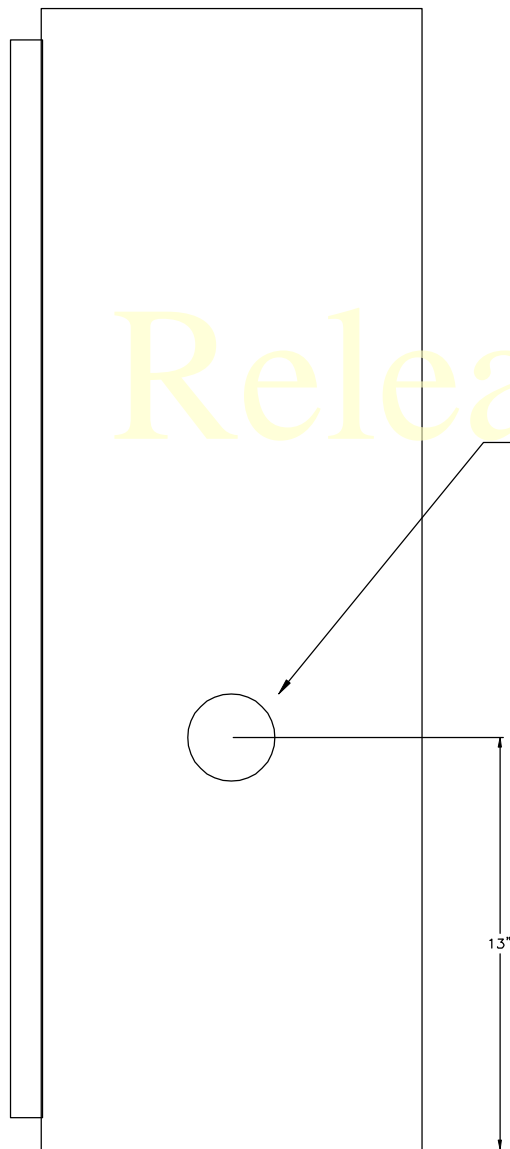

Released for Production
07-11-21

ITEM	QTY.	PART NAME	MATERIAL AND/ OR DESCRIPTION	LENGTH	CODE	DWG. NO./PART NO.
72	1 EA	LABEL-DANGER-ARC FLASH	HCS #5022301C		X P	691411
71	1 EA	LABEL-WARNING DO NOT START	HCS #BSM6000-B39WHBS		X P	691518
70	1 EA	LABEL-NOTICE TURN ELEC.	HCS #BSMH6058-746NHBS		X P	691701
69	1 EA	LABEL-WARNING HAZARDOUS	HCS #BSM5025-742WHBS		X P	691507
68	1 EA	HORIZ,STKR,4-ZN,PNL,LAYOUT,PLYWOOD	SEE DRAWING		X M	C70304
67	400 FT	WIRE,MTW,	#16 AWG		X P	508006
66	200 FT	WIRE,COLORS	12 THIN		X P	508862
65	200 FT	WIRE,COLORS	8 THIN		X P	508864
64	7 FT	MOUNTING RAIL,DM	IDEC #BND-1000		X P	146122
63	13 EA	TY-WRAP,7-1/4",WHITE,MED	RAYBRO #TY-525M		X P	508701
62	30 EA	TY-WRAP,MED,5-1/2	TY-524M		X P	508710
61	30 EA	TY-WRAP,LIGHT,3-1/2	TY-523M		X P	508700
60	15 EA	PAD,PRESSURE,TYWRAP	#TC-5342A		X P	504313
59	75 EA	TY-WRAP,7-1/4",BLACK	TY-525MX		X P	508704
58	1 EA	NAMEPLATE,E-STOP	GE #P9ACPBS229		X P	513683
57	1 EA	NAMEPLATE,HOLDER	GE #P9ARTBS		X P	513676
56	1 EA	LIGHT,120VAC,X-FORM	GE #P9PTNVJ		X P	513652
55	1 EA	CONTACT,BLOCK,1NO/NC	GE #P98IVN		X P	513651
54	1 EA	OPER,P-B,RED,MUSHROOM	GE #P9CET4RL1		X P	513654
53	5 EA	JUMPER,BAR,10-POLE,BJM6	ENTRELEC #168973.07		X P	518143
52	6 EA	END,SECTION,COMPRESSION-CLAMP	ENTRELEC #199336.20		X P	518221
51	116 EA	TERMINAL,BLOCK,ADO-FIELD	ENTRELEC #199034.15		X P	518220
50	6 EA	END,STOP,screwless	ENTRELEC #199408.02		X P	518192
49	20 EA	RIVET-POP,5/32	#ABA53		X P	390005
48	4 EA	SCW,RDHD,SL	1/4-20x3/8	L-CODITIONER	P	341151
47	4 EA	WSHR,FLT	#10	DISC SW	P	365109
46	4 EA	WSHR,LCK,TYP.M	1/4	L-CODITIONER	P	364034

REV.	DATE	DESCRIPTION	BY	CHK'D	APP'D	DATE
45	8 EA	WSHR,LCK,#10,TYP.M	WSHR,LCK,#10,TYP.M	XFMR/PLC	P	364026
44	12 EA	SCW,RDHD,SL	10-32x3/8	XFMR/DISC/PLC	P	341103
43	2 EA	LOCKNUT,FLEX,BL-75,3/4,GALV	3/4	BEACON	P	511193
42	4 EA	NUT,HEX,FINISHED	3/8-16	MAIN ENCL.	P	361605
41	4 EA	WSHR,LCK,SAE	3/8	MAIN ENCL.	P	364042
40	4 EA	WSHR,FLT,SAE	3/8	MAIN ENCL.	P	365123
39	4 EA	C'SCW,HXHD	3/8-16x1-3/4	MAIN ENCL.	P	327267
38	1 EA	KIT,FUSE,PRIMARY XFORMER	ACME #PL112700	208V	P	516400
37	1 EA	KIT,FUSE,SECONDARY,XFMR	ACME #PL112603	208V	P	516401
36	4 EA	CIRCUIT BRKR,1-POLE,2 A,277VAC	GE #V07102	X	P	516423
35	1 EA	NIPPLE,BI.SCH80,CLOSE	3/4	BEACON	P	714601
34	1 EA	RS232,CABLE,TCP/CMM311	TCP #HMI-CAB-C53	X	P	504455
33	1 EA	GROUNDING,BAR	SQUARE-D #PK7GTA	X	P	504229
32	2 EA	RELAY,MODULE,RB122AR	ENTRELEC #010011.17	X	P	514186
31	1 EA	LENS,MODULE,BLUE	EDWARDS #102-LM-B	BEACON	P	513526
30	1 EA	LENS,MODULE,AMBER	EDWARDS #102-LM-A	BEACON	P	513522
29	1 EA	LENS,MODULE,GREEN	EDWARDS #102-LM-G	BEACON	P	513525
28	1 EA	LENS,MODULE,RED	EDWARDS #102-LM-R	BEACON	P	513527
27	1 EA	BEACON,TOWER,BASE,120VAC,120V,3/4"	EDWARDS #120PMBS-N5	BEACON	P	513521
26	4 EA	BEACON,LIGHT,H LGEN,STDY	EDWARDS #102LS-FINH-N5	BEACON	P	513528
25	12 FT	COVER,DUCT,WIRING,PVC	PANDUIT #C2 LG6	X	P	510152
24	12 FT	WIRING,DUCT,PVC	PANDUIT #G2 x 3LG6	X	P	510142
23	1 EA	TOUCHSCREEN,6"DISPLAY	TCP #CQPKSTDN0000,	X	P	504299
22	1 EA	PLC,COMMUNICATION,90-30	GE #IC693CMM311	X	P	504415
21	1 EA	TERM,MARKER,KIT,H-STACKER,4-ZONE	ENTRELEC #RC610	X	P	518310
20	1 EA	RELAY,CONTROL	GE# CR120B02202	X	P	514071
19	2 EA	FUSE,8 A	BUSS #LPJ-8SP	208V/230V	P	516487
19	2 EA	FUSE,4 A	BUSS #LPJ-4SP	460V	P	516484
18	5 EA	END,SECTION,ADO-ADO	ENTRELEC #199341.05	X	P	518203
17	69 EA	TERMINAL,BLOCK,ADOADO	ENTRELEC #199051.26	X	P	518202
16	2 EA	PLC,OUTPUT,120V,16POINT	GE #IC693MDL340	X	P	504405
15	6 EA	PLC,INPUT,AC,16POINT	GE #IC693MDL240	X	P	504403
14	1 EA	PLC,POWER SUPPLY,120VAC	GE #IC693PWR321	X	P	504407
13	1 EA	PLC,RACK,10-SLOT	GE #IC693CHS391	X	P	504412
12	1 EA	PLC,CPU,16K	GE #IC693CPU331	X	P	504402
11	3 EA	CIRCUIT-BREAKER,AUX-CONT,1NO/1NC	GE #VAUX1	X	P	516466
10	1 EA	CIRCUIT-BREAKER,1-POLE,1 A,277VAC	GE #V07101	X	P	516422
9	1 EA	FUSE,10A	BUSSMANN #FNQ-R-10	X	P	516385
8	2 EA	FUSE,CLASS-CC,8AMP	BUSSMANN #FNQ-R-8	208V/230V	P	516391
8	2 EA	FUSE,CLASS-CC,4AMP	BUSSMANN #FNQ-R-4	460V	P	516389
7	1 EA	DISC,HANDLE,OFF/ON	BUSSMANN #BDH106	X	P	509423
6	1 EA	DISC,SHAFT,10.4",.2x.2,PISTOL-HANDLE	BUSSMAN #CDS49P	X	P	509399
5	1 EA	DISC,SWITCH,30A,FUSED	BUSSMANN #BDCF30J6	X	P	509422
4	1 EA	CONDITIONER,250VA	SOLA #63-23-125-4	X	P	509108
3	1 EA	TRANSFORMER,1000VA	ACME #TA-2-81309	208V	P	509174
3	1 EA	TRANSFORMR 1000VA	ACME #TA2-81217	460V/230V	P	509087
2	1 EA	PANEL	HOFFMAN #A-36P36	X	P	477085
1	1 EA	ENCLOSURE	HOFFMAN #A-363612LP	519041	M	90436-101

DIMENSION TOLERANCES, UNLESS OTHERWISE SPECIFIED:
 FRACTIONS ± [1/32] DECIMALS ± [0.01] ANGLES ± [1°]
 TOTAL RUNOUT ± [0.004] MACHINED SURFACES NOT SPECIFIED [0.004]

THIS DRAWING AND/OR DATA SHEET, AND THE CONFIDENTIAL PROPRIETARY INFORMATION THEREON, IS THE PROPERTY OF MITEK INDUSTRIES, INC. AND IS NOT TO BE REPRODUCED OR COPIED IN WHOLE OR IN PART, OR USED FOR UNAUTHORIZED MANUFACTURING OR ANY OTHER EXPLOITATION OF THE ITEM DISCLOSED THEREIN, OR IN ANY OTHER WAY DISCLOSED OR USED FOR FURNISHING INFORMATION.

ASSEMBLY 501 PARTS LIST

MiTek Industries, Inc.
 4203 SHORELINE DRIVE, EARTH CITY, MO. 63045

APPROVED: VDC DATE: MFG. DATE: FINISH PAINT: SCALE: PAGE: 16 of 22
 CHECKED: DATE: DRAWN: VCarroll DATE: FINISH PAINT: SCALE: NONE PAGE: 16 of 22
HORIZONTAL STACKER, 2/4-ZONE
B90436

PUSH BUTTON PANEL

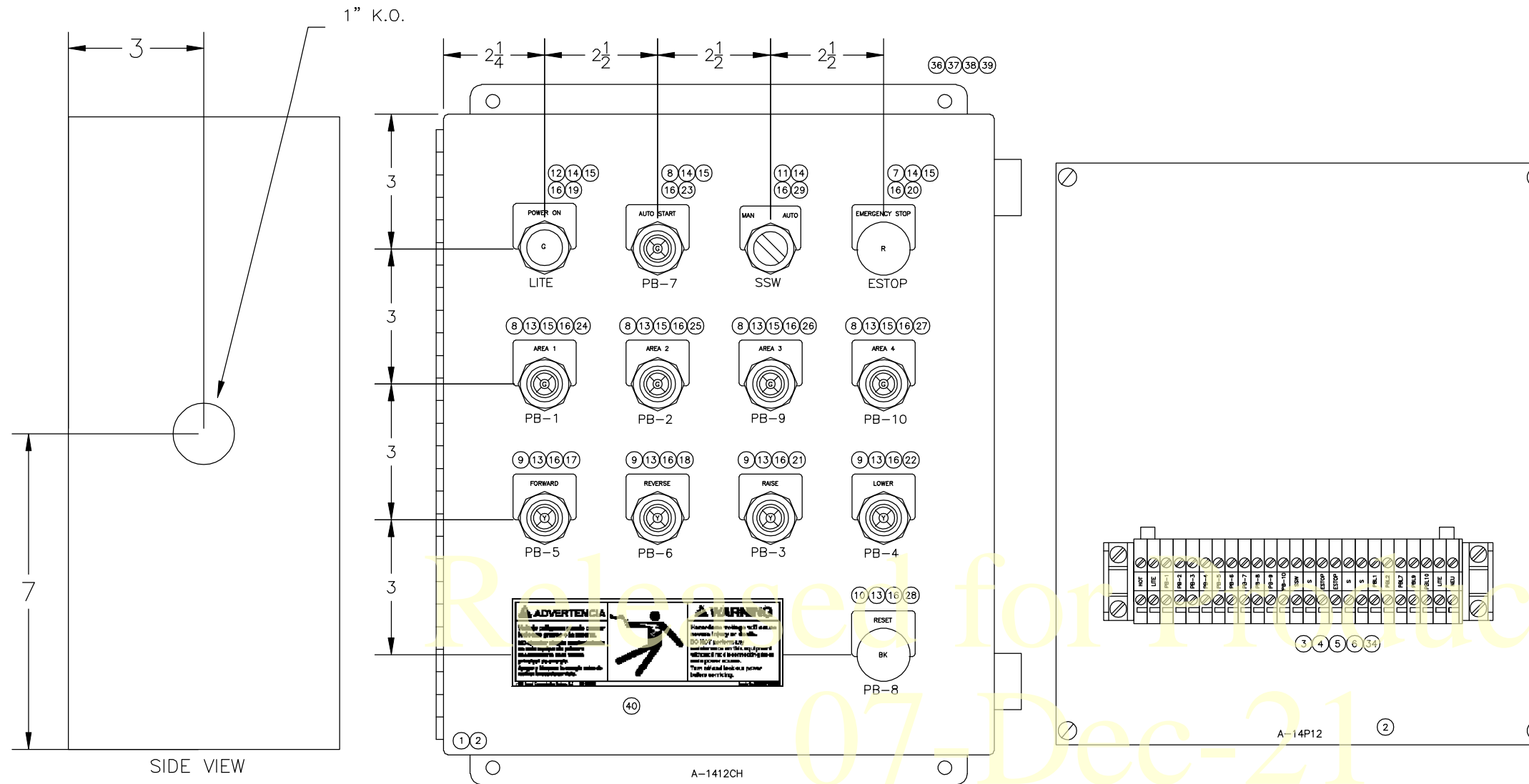

40	1 EA	LABEL-WARNING HAZARDOUS	HCS #BSM5025-742WHBT		P	691509
39	4 EA	WASHR,LCK,TYP.M	1/4		P	364034
38	4 EA	NUT,HEX,FINISHED	1/4-20		P	361601
37	4 EA	WSHR,FLT,SAE,TYP.A,N	1/4x5/8x.049		P	365115
36	4 EA	C'SCW,HXHD,GR.5	1/4-20x3/4		P	327157
35	30 FT	WIRE,MTW,RED	#16 AWG		P	508006
35	2 FT	WIRE,MTW,WHITE	#16 AWG		P	508006
34	1 FT	MOUNTING,RAIL,DIN	IDEC #BND-1000		P	146122
33	20 EA	TY-WRAP,MED.,5-1/2	#TY-524M		P	508710
32	20 EA	TY-WRAP,LIGHT,3-1/2	#TY-523M		P	508700
31	10 EA	PAD,PRESSURE,TYWRAP	#TC-5342A		P	504313
30	25 EA	TY-WRAP,7-1/4",BLACK	TY-525MX		P	508704
29	1 EA	NAMEPLATE,MAN OFF AUTO	GE #P9ACPBS269		P	513699
28	1 EA	NAMEPLATE,RESET	GE #P9ACPBS291		P	513748
27	1 EA	NAMEPLATE,FIG.A,AREA 4,BLACK	GE #P9ARTBSEN		P	513747
26	1 EA	NAMEPLATE,FIG.A,AREA 3,BLACK	GE #P9ARTBSEN		P	513746
25	1 EA	NAMEPLATE,FIG.A,AREA 2,BLACK	GE #P9ARTBSEN		P	513745
24	1 EA	NAMEPLATE,FIG.A,AREA 1,BLACK	GE #P9ARTBSEN		P	513744
23	1 EA	NAMEPLATE,AUTO START	GE #P9ACPBS219		P	513685
22	1 EA	NAMEPLATE,LOWER	GE #P9ACPBS217		P	513687
21	1 EA	NAMEPLATE,RAISE	GE #P9ACPBS216		P	513686
20	1 EA	NAMEPLATE,E-STOP	GE #P9ACPBS229		P	513683
19	1 EA	NAMEPLATE,POWER-ON	GE #P9ACPBS240		P	513682
18	1 EA	NAMEPLATE,REVERSE	GE #P9ACPBS215		P	513681
17	1 EA	NAMEPLATE,FORWARD	GE #P9ACPBS214		P	513680
16	13 EA	NAMEPLATE,HOLDER	GE #P9ARTBS		P	513676
15	7 EA	LIGHT,120VAC,X-FORM	GE #P9PTNVJ		P	513652
14	4 EA	CONTACT,BLOCK,1NO/1NC	GE #P9BIIVN		P	513651
13	9 EA	CONTACT,BLOCK,1-N.O.	GE #P9B10VN		P	513649
12	1 EA	LIGHT,GREEN,LENS	GE #P9CLVD		P	513646
11	1 EA	SWITCH,2-POSITION,MAINTAINED	GE #P9CSMDON		P	513644
10	1 EA	BUTTON,BLACK,MUSHROOM,MMNTRY	GE #P9CEMANN		P	513658
9	4 EA	BUTTON,YEL,EXTENDED,MMNTRY	GE #P9CPNGS		P	513657
8	5 EA	PUSH-BUTTON,GREEN,EXT,ILLUM,MMTRY	GE #P9CPLVSD		P	513664
7	1 EA	OPER,P-B,RED,MUSHROOM	GE #P9CET4RL1		P	513654
6	1 EA	JUMPER,BAR,10-POLE,BJM6	ENTRELEC #168973.07		P	518143
5	1 EA	END,SECTION,COMPRESSION-CLAMP	ENTRELEC #199336.20		P	518221
4	25 EA	TERMINAL,BLOCK,ADO-FIELD	ENTRELEC #199336.15		P	518220
3	2 EA	END,STOP,screwless	ENTRELEC #199 408.02		P	518192
2	1 EA	PANEL 14x12	HOFFMAN #A-14P12		P	519071
1	1 EA	ENCLOSURE 14x12x06	HOFFMAN #A-1412CHNF	519040	M	90436-104

SEE PAGE 17 FOR CABLE WIRING & TERMINAL BLOCK DETAILS

ALL PUSH BUTTONS AND PILOT LIGHTS WILL BE TERMINATED TO THE PROPER TERMINAL BLOCK. A LIST OF ALL CONNECTIONS ARE AS FOLLOWS:

PUSH BUTTON w/ PILOT LIGHT	PUSH BUTTON ONLY	PILOT LIGHT ONLY
PB-1 AREA 1 PBL1	PB-3 RAISE	LITE POWER ON
PB-2 AREA 2 PBL2	PB-4 LOWER	
PB-9 AREA 3 PBL9	PB-5 FORWARD	SELECTOR SWITCH
PB-10 AREA 4 PBL10	PB-6 REVERSE	SSW AUTO/MAN
PB-7 AUTO START PBL7	PB-8 RESET	
E-STOP		

FROM THIS DWG, PAGE 3
E-STOP DETAILS

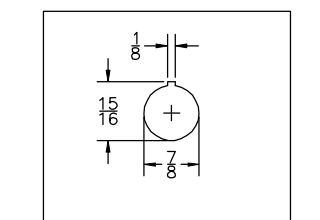
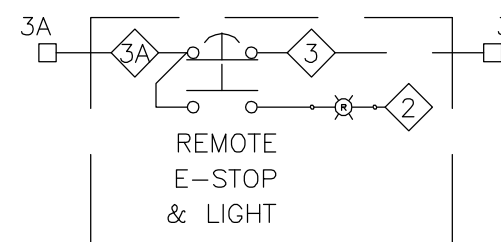

PB/SS HOLE PATTERN

DIMENSION TOLERANCES, UNLESS OTHERWISE SPECIFIED:
 FRACTIONS ± [1/32] DECIMALS ± [0.01] ANGLES ± [1°]
 TOTAL RUNOUT ± [0.004] MACHINED SURFACES NOT SPECIFIED [0.004]

THIS DRAWING AND/OR DATA SHEET, AND THE CONFIDENTIAL PROPRIETARY INFORMATION THEREON, IS PROPERTY OF MITEK INDUSTRIES, INC. AND IS NOT TO BE REPRODUCED OR COPIED IN WHOLE OR IN PART, OR USED FOR UNAUTHORIZED MANUFACTURING OR ANY OTHER EXPLOITATION OF THE ITEM DISCLOSED THEREIN, OR IN ANY OTHER WAY DISCLOSED OR USED FOR FURNISHING INFORMATION.

MITEK INDUSTRIES, INC.
 4203 SHORELINE DRIVE, EARTH CITY, MO. 63045

APPROVED: VDC DATE: MFC: **HORIZONTAL STACKER, 2/4-X**
 CHECKED: DATE: DRAWN: VCarroll DATE: FINISH PAINT: SCALE: NONE PAGE: 17 of 22 **B90436** DASH NO.: 504 REV.: G

Cable Color Code Chart for PB Panel

Cable #508406 16awg 25 Conductor

Wire# Color

- 2 White
- 1 Red
- Gnd Green
- 3 Orange
- 3A Blue
- IN33 White/Black
- IN34 Red/Black
- IN35 Green/Black
- IN36 Orange/Black
- IN37 Blue/Black
- IN38 Black/White
- IN39 Red/White
- IN40 Green/White
- IN41 Blue/White
- IN42 Black/Red
- IN56 White/Red
- Q6 Orange/Red
- Q7 Blue/Red
- Q14 Red/Green
- Q22 Orange/Green
- Q30 Black

- Spare Black/White/Red
- Spare White/Black/Red
- Spare Red/Black/White
- Spare Green/Black/White

PUSH BUTTON PANEL TERMINALS

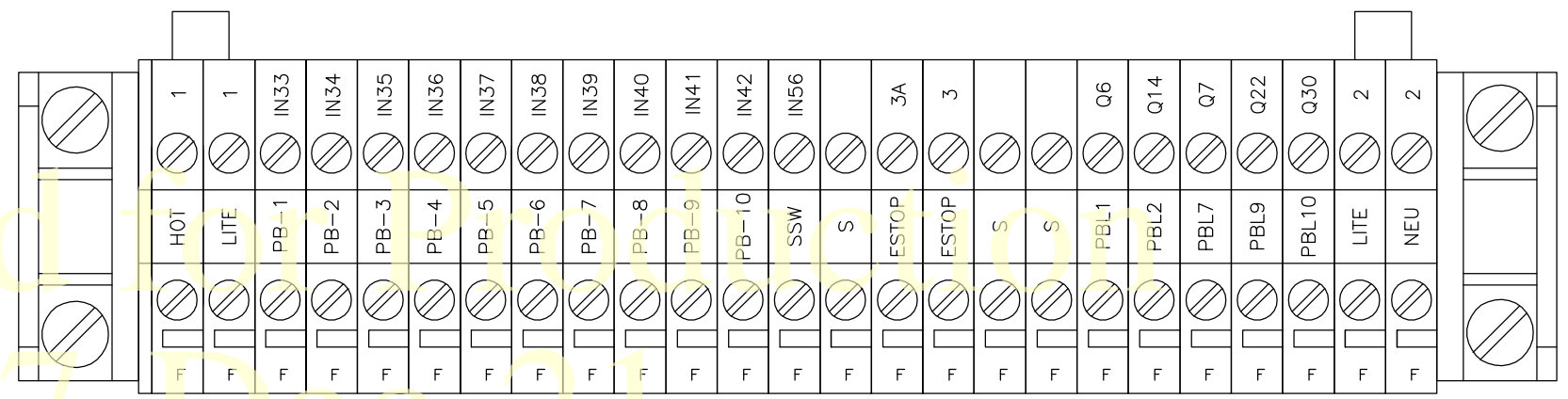

Released
07-Dec-21

ITEM	QTY.	PART NAME	MATERIAL AND/OR DESCRIPTION	LENGTH	CODE	DWG. NO./PART NO.
<small>DIMENSION TOLERANCES, UNLESS OTHERWISE SPECIFIED: FRACTIONS ± [1/32] DECIMALS ± [0.01] ANGLES ± [1°] TOTAL RUNOUT ± [] MACHINED SURFACES NOT SPECIFIED [20°]</small>						
<small>*THIS DRAWING AND/OR DATA SHEET, AND THE CONFIDENTIAL PROPRIETARY INFORMATION THEREON, IS PROPERTY OF MITEK INDUSTRIES, INC. AND IS NOT TO BE REPRODUCED OR COPIED IN WHOLE OR IN PART, OR USED FOR UNAUTHORIZED MANUFACTURING OR ANY OTHER EXPLOITATION OF THE ITEM DISCLOSED THEREIN, OR IN ANY OTHER WAY DISCLOSED OR USED FOR FURNISHING INFORMATION.*</small>						
TERMINAL BLOCK LAYOUT						
APPROVED	VDC	DATE	MFG.	HORIZONTAL STACKER, 2/4-ZONE		
CHECKED		DATE	DRAWN	DATE	FINISH PAINT	SCALE
		2/22/02	VCarroll		X	NONE
				PAGE	18 of 22	DASH NO. REV.
					B90436	G

MAIN CONTROL PANEL TERMINALS

RADIO CONTROL OPTIONS

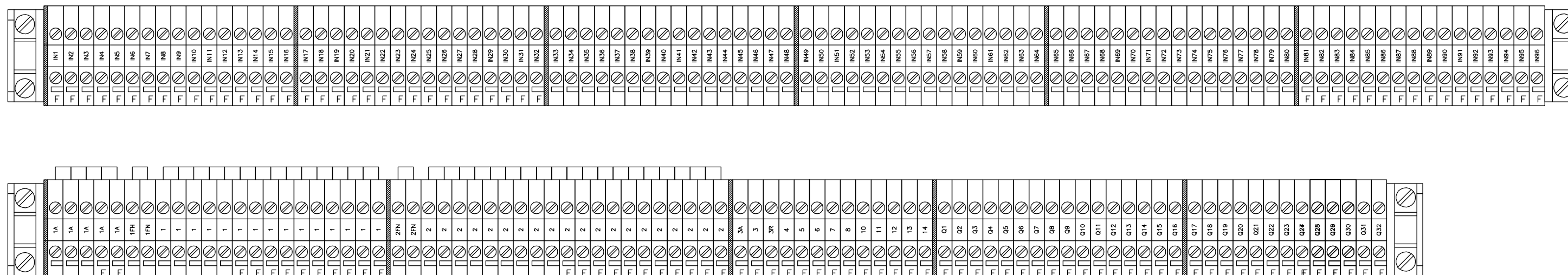

Released for Production
07-Dec-21

CABLE COLOR CODE CHART FOR RADIO WIRING

CABLE #508755 16awg 19 CONDUCTOR

Wire#	Color	Wire#	Color
2	Brown	IN85	Brown/Red
1	Red	IN86	Black/Blue
Gnd	Brown/Black	IN87	Yellow
3R	Orange	IN88	Yellow/Black
4	Blue	IN89	Black/Red
CB-4	Red/Blue	IN90	Yellow/Red
IN81	Red/Black	IN91	Orange/Red
IN82	Orange/Blue	IN92	Blue/Red
IN83	Orange/Black	Spare	Black
IN84	Blue/Black		

ITEM	QTY.	PART NAME	MATERIAL AND/OR DESCRIPTION	LENGTH	CODE	DWG.NO./PART NO.
<small>DIMENSION TOLERANCES, UNLESS OTHERWISE SPECIFIED: FRACTIONS ± [1/32] DECIMALS ± [0.01] ANGLES ± [1°] TOTAL RUNOUT ± [] MACHINED SURFACES NOT SPECIFIED [25/]</small>			<small>THIS DRAWING AND/OR DATA SHEET, AND THE CONFIDENTIAL PROPRIETARY INFORMATION THEREON, IS PROPERTY OF MITEK INDUSTRIES, INC. AND IS NOT TO BE REPRODUCED OR COPIED IN WHOLE OR IN PART, OR USED FOR UNAUTHORIZED MANUFACTURING OR ANY OTHER EXPLOITATION OF THE ITEM DISCLOSED THEREIN, OR IN ANY OTHER WAY DISCLOSED OR USED FOR FURNISHING INFORMATION.</small>			
TERMINAL BLOCK LAYOUT						
APPROVED	VDC	DATE	MFG.	HORIZONTAL STACKER, 2/4-ZONE		
CHECKED		DATE	DRAWN	DATE	FINISH PAINT	SCALE
			VCarroll	2/22/02	X	NONE
				PAGE	19 of 22	DASH NO. B90436
				REV.		G

NOTES:
 ① ITEMS 13-16 SHIP LOOSE

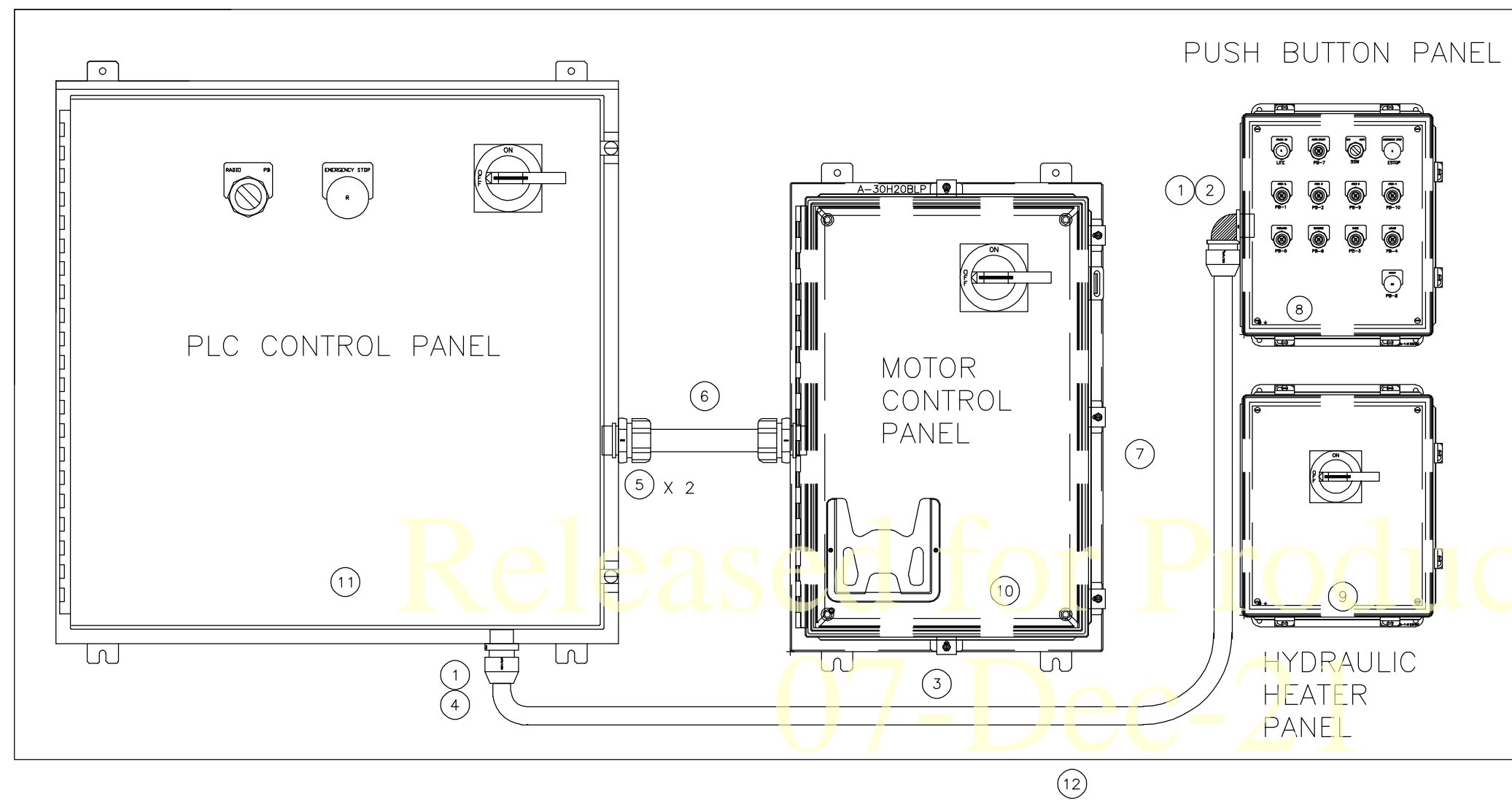

TABLE FOR 2 ZONES SYSTEMS

ASSY	ITEM 11	ITEM 10	ITEM 9	ITEM 16
90436-520-575V	-501-460V	-502-460V	-503-460V	509171
90436-520-460V	-501-460V	-502-460V	-503-460V	-
90436-520-230V	-501-230V	-502-230V	-503-230V	-
90436-520-208V	-501-208V	-502-208V	-503-208V	-

-520 IS A 2 ZONE SYSTEM

ITEM	QTY.	PART NAME	MATERIAL AND/ OR DESCRIPTION	LENGTH	CODE	DWG.NO./PART NO.
16	1 EA	T'FORMER,600/480,3PH,30KVA	(ACME) T-2-52705-1	575V	P	509171
15	2 EA	TRAFFIC COP S/A-HORZ. STACKER		X	M	70530
14	1 EA	PHOTOEYE,RECEVR,CABLE-CON	(AB) 42SRR-6007	X	P	477012
13	1 EA	PHOTOEYE,LIGHT,CABLE-CON	(AB) 42SRL-6006	X	P	477011
12	1 EA	PLYWOOD	1" X 4' X 8'	X	P	85000640000
11	1 EA	CONTROL PANEL ENCLOSURE ASSY	ASSY-501	X	P	SEE TABLE
10	1 EA	MTR ENCLOSURE ASSY	ASSY-502	X	P	SEE TABLE
9	1 EA	HEATER ENCLOSURE ASSY	ASSY-503	X	P	SEE TABLE
8	1 EA	PUSH BUTTON ENCLOSURE ASSY	ASSY-504	X	P	90436-504
7	1 EA	HOLE PLUG 1 1/4" GASKETED	HOFFMAN A-S125	X	P	513131
6	1 FT	CONDUIT-EMT	1-1/4	X	P	510110
5	2 EA	CONN,FLEX,STR,5235	T&B 1-1/4	X	P	511095
4	1 EA	CONN,CABLE,STR,1"CRD,870/1.020	T&B #2678	X	P	511493
3	25 FT	CABLE,16/25,DIA=0.906	BELDON #9622	X	M	508406
2	1 EA	CONN,CABLE,90DEG,1",870/1.020	T&B #2687	X	P	511510
1	2 EA	LOCKNUT,FLEX,1",GALV	APPLETON #BL-100	X	P	511194

DIMENSION TOLERANCES, UNLESS OTHERWISE SPECIFIED:
 FRACTIONS ± [1/32] DECIMALS ± [0.010] ANGLES ± [1°]
 TOTAL RUNOUT ± [] MACHINED SURFACES NOT SPECIFIED []

THIS DRAWING AND/OR DATA SHEET, AND THE CONFIDENTIAL PROPRIETARY INFORMATION THEREON, IS PROPERTY OF MITEK INDUSTRIES, INC. AND IS NOT TO BE REPRODUCED OR COPIED IN WHOLE OR IN PART, OR USED FOR UNAUTHORIZED MANUFACTURING OR ANY OTHER EXPLOITATION OF THE ITEM DISCLOSED THEREIN, OR IN ANY OTHER WAY DISCLOSED OR USED FOR FURNISHING INFORMATION.

FEATURES: DIMENSIONS FINISH PAINT SCALE NONE PAGE 20 of 22 DASH NO. B90436 REV. G

APPROVED: VDC DATE: MFG. DATE: 2/22/02
 CHECKED: DATE: DRAWN: VCarroll
 MiTek Industries, Inc. 4203 SHORELINE DRIVE, EARTH CITY, MO. 63045

NOTES:
 ① ITEMS 13-16 SHIP LOOSE

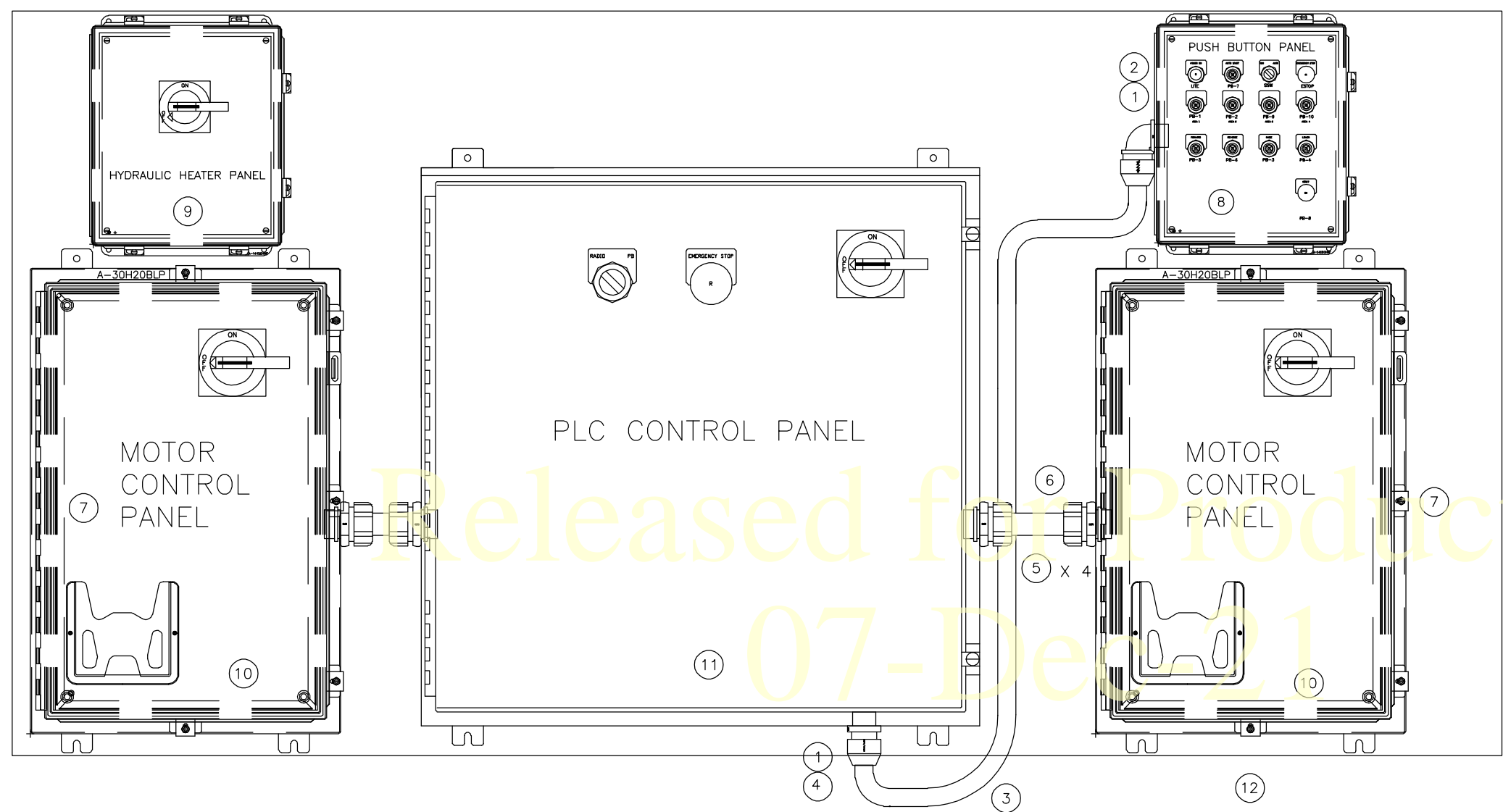

Released for Production
07-Dec-21

TABLE FOR 4 ZONES SYSTEMS

ASSY	ITEM 11	ITEM 10	ITEM 9	ITEM 16
90436-540-575V	-501-460V	-502-460V	-503-460V	509171
90436-540-460V	-501-460V	-502-460V	-503-460V	-
90436-540-230V	-501-230V	-502-230V	-503-230V	-
90436-540-208V	-501-208V	-502-208V	-503-208V	-

-540 IS A 4 ZONE SYSTEM

ITEM	QTY	PART NAME	MATERIAL AND/ OR DESCRIPTION	LENGTH	CODE	DWG. NO./PART NO.
16	1 EA	T ¹ FORMER,600/480,3PH,30KVA	(AGME) T-2-52705-1	575V	P	509171
15	4 EA	TRAFFIC COP S/A-HORZ. STACKER	SEE DRAWING	X	M	D70530
14	2 EA	PHOTOEYE,RECEVR,CABLE-CON	(AB) 42SRR-6007	X	P	477012
13	2 EA	PHOTOEYE,LIGHT,CABLE-CON	(AB) 42SRL-6006	X	P	477011
12	1 EA	PLYWOOD	1" X 4' X 8'	X	P	85000640000
11	1 EA	CONTROL PANEL ENCLOSURE ASSY	ASSY-501	X	P	SEE TABLE
10	2 EA	MTR ENCLOSURE ASSY	ASSY-502	X	P	SEE TABLE
9	1 EA	HEATER ENCLOSURE ASSY	ASSY-503	X	P	SEE TABLE
8	1 EA	PUSH BUTTON ENCLOSURE ASSY	ASSY-504	X	P	90436-504
7	2 EA	HOLE PLUG 1 1/4" GASKETED	HOFFMAN A-S125	X	P	513131
6	1 FT	CONDUIT-EMT	1-1/4	X	P	510110
5	4 EA	CONN,FLEX,STR,5235	T&B 1-1/4	X	P	511095
4	1 EA	CONN,CABLE,STR,1"CRD,870/1.020	T&B #2678	X	P	511493
3	25 FT	CABLE,16/25,DIA=0.906	BELDON #9622	X	M	508406
2	1 EA	CONN,CABLE,90DEG,1",870/1.020	T&B #2687	X	P	511510
1	2 EA	LOCKNUT,FLEX,1",GALV	APPLETON #BL-100	X	P	511194

DIMENSION TOLERANCES, UNLESS OTHERWISE SPECIFIED:
 FRACTIONS ± [1/32] DECIMALS ± [0.010] ANGLES ± [1°]
 TOTAL RUNOUT ± [] MACHINED SURFACES NOT SPECIFIED []

THIS DRAWING AND/OR DATA SHEET, AND THE CONFIDENTIAL PROPRIETARY INFORMATION THEREON, IS PROPERTY OF MITEK INDUSTRIES, INC. AND IS NOT TO BE REPRODUCED OR COPIED IN WHOLE OR IN PART, OR USED FOR UNAUTHORIZED MANUFACTURING OR ANY OTHER EXPLOITATION OF THE ITEM DISCLOSED THEREON, OR IN ANY OTHER WAY DISCLOSED OR USED FOR FURNISHING INFORMATION.

MITEK Industries, Inc.
 4203 SHORELINE DRIVE, EARTH CITY, MO. 63045

APPROVED	VDC	DATE	MFG.	HORIZONTAL STACKER, 2/4-ZONE			
CHECKED		DATE	DRAWN	DATE	FINISH PAINT	SCALE	PAGE
			VCarroll	2/22/02	X	NONE	21 of 22

DASH NO. **B90436** REV. **G**

REV.	DATE	DESCRIPTION	BY	CHK'D	APP'D
------	------	-------------	----	-------	-------

RESERVED

Released for Production
07-Dec-21

ITEM	QTY.	PART NAME	MATERIAL AND/ OR DESCRIPTION	LENGTH	CODE	DWG.NO./PART NO.
DIMENSION TOLERANCES, UNLESS OTHERWISE SPECIFIED: FRACTIONS ± [1/32] DECIMALS ± [0.01] ANGLES ± [1°]			THIS DRAWING AND/OR DATA SHEET, AND THE CONFIDENTIAL PROPRIETARY INFORMATION THEREON, IS PROPERTY OF MITEK INDUSTRIES, INC. AND IS NOT TO BE REPRODUCED OR COPIED IN WHOLE OR IN PART, OR USED FOR UNAUTHORIZED MANUFACTURING OR ANY OTHER EXPLOITATION OF THE ITEM DISCLOSED THEREIN, OR IN ANY OTHER WAY DISCLOSED OR USED FOR FURNISHING INFORMATION.			
TOTAL RUNOUT ± [] MACHINED SURFACES NOT SPECIFIED [20]			 MiTek Industries, Inc. 4203 SHORELINE DRIVE, EARTH CITY, MO. 63045			
APPROVED	VDC	DATE	MFG.	HORIZONTAL STACKER, 2/4-ZONE		
CHECKED		DATE	DRAWN	DATE	FINISH PAINT	SCALE
			VCarroll	2/22/02	X	NONE
				PAGE	22 of 22	DASH NO. REV.
					B90436	G