

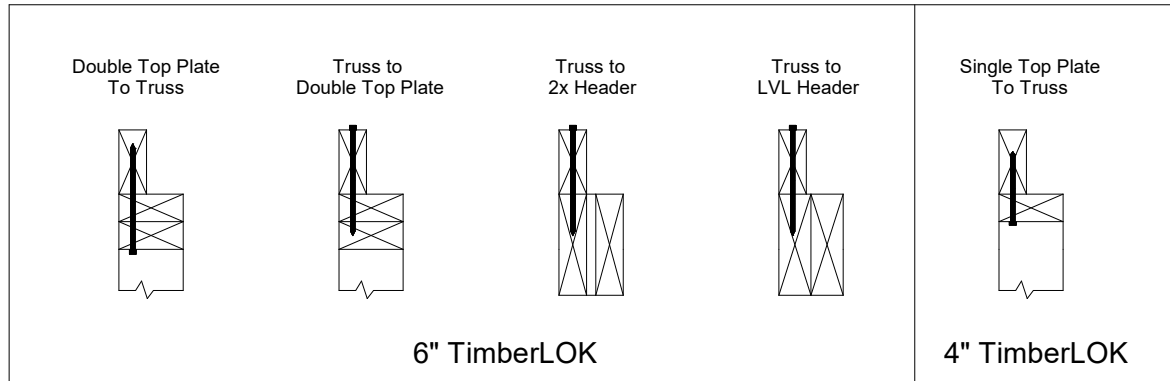

NOTES:

1. SELECT A TimberLOK SCREW WITH A LENGTH SUFFICIENT TO FULLY EMBED THE 2" THREADED PORTION OF THE SCREW INTO THE MAIN MEMBER(S).
2. INSTALL THE REQUIRED NUMBER OF SCREWS TO ACHIEVE THE REQUIRED LATERAL CAPACITY AND THE UPLIFT LOADS USING THE TimberLOK DESIGN CAPACITIES FOR THE RESISTANCE TO THE UPLIFT AND LATERAL LOADS. WHEN BOTH ARE USED, TYPICAL INTERACTION EQUATIONS ARE REQUIRED, SEE NOTE 6 BELOW.
3. WHEN INSTALLED FROM THE TOP DOWN, CENTER THE SCREW ON THE TRUSS CHORD AND DRIVE VERTICALLY UNTIL THE HEAD OF THE SCREW IS FLUSH TO THE TOP OF THE CHORD. DO NOT OVERDRIVE.
4. WHEN INSTALLED UPWARD INTO THE BOTTOM OF A DOUBLE TOP PLATE, MEASURE 3/4" FROM THE OUTER EDGE OF THE BOTTOM PLATE AND DRIVE THE SCREW VERTICALLY UNTIL THE HEAD IS FLUSH TO THE UNDERSIDE OF THE TOP PLATE. DO NOT OVERDRIVE.
5. USE THE LOWER OF THE TWO VALUES IF MIXED SPECIES ARE INVOLVED.
6. LOADS ACTING IN TWO DIRECTIONS SIMULTANEOUSLY MUST BE EVALUATED AS FOLLOWS:
DESIGN SHEAR/ ALLOWABLE SHEAR + DESIGN UPLIFT/ ALLOWABLE UPLIFT <=1.0
7. SCREW SPACING ALONG THE WALL TOP PLATE:
MAXIMUM SCREW SPACING = 24" O.C MINIMUM SCREW SPACING = 6" O.C.



Wood Species	SPF/HF			Douglas Fir			Southern Pine		
	Uplift	Lateral/Shear		Uplift	Lateral/Shear		Uplift	Lateral/Shear	
		Parallel to Wall	Perpendicular to Wall		Parallel to Wall	Perpendicular to Wall		Parallel to Wall	Perpendicular to Wall
Allowable Load	420	320	370	540	385	425	620	410	450

A STANDARD LOAD DURATION FACTOR OF 1.6 HAS BEEN APPLIED TO THESE VALUES PER NDS TABLE 2.3.2

Wood Species	On Center Spacing Between Screws (inches)					
	6"	8"	12"	16"	18"	24"
SPF/HF	640	475	320	240	215	160
Douglas Fir	770	575	385	290	255	195
Southern Pine	820	615	410	310	275	205

A STANDARD LOAD DURATION FACTOR OF 1.6 HAS BEEN APPLIED TO THESE VALUES PER NDS TABLE 2.3.2