

PROVIDE 2x4 BLOCKING BETWEEN THE FIRST TWO TRUSSES AS NOTED. TOENAIL BLOCKING TO TRUSSES WITH (2) - 10d NAILS AT EACH END. ATTACH DIAGONAL BRACE TO BLOCKING WITH (5) - 10d NAILS.

(4) - 8d (0.131" X 2.5") NAILS MINIMUM, PLYWOOD SHEATHING TO 2x4 STD SPF BLOCK

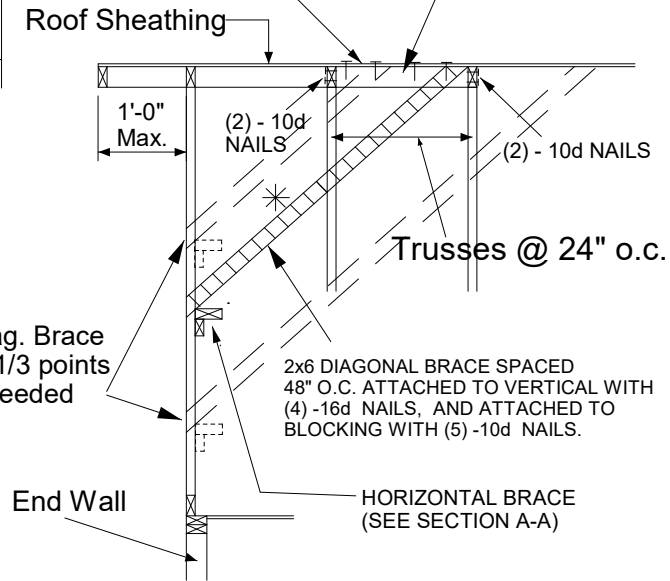

- * - Diagonal Bracing Refer to Section A-A
 - ** - L-Bracing Refer to Section B-B
- NOTE:
1. MINIMUM GRADE OF #2 MATERIAL IN THE TOP AND BOTTOM CHORDS.
 2. CONNECTION BETWEEN BOTTOM CHORD OF GABLE END TRUSS AND WALL TO BE PROVIDED BY PROJECT ENGINEER OR ARCHITECT.
 3. BRACING SHOWN IS FOR INDIVIDUAL TRUSS ONLY. CONSULT BLDG. ARCHITECT OR ENGINEER FOR TEMPORARY AND PERMANENT BRACING OF ROOF SYSTEM.
 4. "L" BRACES SPECIFIED ARE TO BE FULL LENGTH, SPF or SP No.3 OR BETTER WITH ONE ROW OF 10d NAILS SPACED 6" O.C.
 5. DIAGONAL BRACE TO BE APPROXIMATELY 45 DEGREES TO ROOF DIAPHRAM AT 4'-0" O.C.
 6. CONSTRUCT HORIZONTAL BRACE CONNECTING A 2x6 AND A 2x4 AS SHOWN WITH 16d NAILS SPACED 6" O.C. HORIZONTAL BRACE TO BE LOCATED AT THE MIDSPAN OF THE LONGEST GABLE STUD. ATTACH TO VERTICAL GABLE STUDS WITH (4) 10d NAILS THROUGH 2x4. (REFER TO SECTION A-A)
 7. GABLE STUD DEFLECTION MEETS OR EXCEEDS L/240.
 8. THIS DETAIL DOES NOT APPLY TO STRUCTURAL GABLES.
 9. DO NOT USE FLAT BOTTOM CHORD GABLES NEXT TO SCISSOR TYPE TRUSSES.
 10. SOUTHERN PINE LUMBER DESIGN VALUES ARE THOSE EFFECTIVE 06-01-13 BY SPIB/ALSC.
 11. NAILS DESIGNATED 10d ARE (0.131" X 3") AND NAILS DESIGNATED 16d ARE (0.131" X 3.5")

Minimum Stud Size Species and Grade	Stud Spacing	Without Brace	2x4 L-Brace	DIAGONAL BRACE	2 DIAGONAL BRACES AT 1/3 POINTS
2x4 SP No. 3 / Stud	12" O.C.	3-9-7	5-8-8	6-11-1	11-4-4
2x4 SP No. 3 / Stud	16" O.C.	3-4-12	4-11-15	6-9-8	10-2-3
2x4 SP No. 3 / Stud	24" O.C.	2-9-4	4-0-7	5-6-8	8-3-13
2x4 SP No. 2	12" O.C.	3-11-13	5-8-8	6-11-1	11-11-7
2x4 SP No. 2	16" O.C.	3-7-7	4-11-5	6-11-1	10-10-5
2x4 SP No. 2	24" O.C.	3-1-15	4-0-7	6-3-14	9-5-14

* Diagonal braces over 6'-3" require a 2x4 T-Brace attached to one edge. Diagonal braces over 12'-6" require 2x4 I-braces attached to both edges. Fasten T and I braces to narrow edge of diagonal brace with 10d nails 6" o.c., with 3" minimum end distance. Brace must cover 90% of diagonal length. T or I braces must be 2x4 SPF No. 2 or SP No. 2.

MAX MEAN ROOF HEIGHT = 30 FEET
 EXPOSURE D
 ASCE 7-10, ASCE 7-16 170 MPH
 DURATION OF LOAD INCREASE : 1.60

STUD DESIGN IS BASED ON COMPONENTS AND CLADDING.
 CONNECTION OF BRACING IS BASED ON MWFRS.