

The LSSH series connects rafters to ridge beams in vaulted roof structures. This series is field adjustable to meet a variety of skew and/or slope applications. Slopes and skews 0° to 45°.

Materials: See chart

Finish: G-185 galvanizing

Options: See chart for Corrosion Finish Options

Codes: IBC, FL, LA

Installation:

- Use all specified fasteners. See Product Notes, page 18.

Steps:

1. Position LSSH connector against plumb-cut end of joist. Fasten joist side flanges on both sides with 10d (0.148") x 1-1/2" nails. Bend seat up to fit against joist bottom and drive (1) 10d (0.148") x 1-1/2" nail through bottom seat into rafter bottom. Drive (2) 10d (0.148") x 1-1/2" nails at downward angle through dimpled nailing guides.
 2. Lean connector and rafter end against ridge beam at desired position. Install specified 10d (0.148" x 3") or 16d (0.162" x 3-1/2") nails through nail holes into ridge beam at right 90° angle. If skewing the rafter, only drive nails into ridge beam on inside flange.
 3. Bend flange to desired angle.
 4. Hammer outside flange until edge touches header. Fasten outside flange to ridge by driving specified 10d (0.148" x 3) or 16d (0.162" x 3-1/2") nails through nail holes.
- Web stiffeners are required for all wood I-Joist installations.
 - Designer may consider adding a tension restraint for the supported member for roof slopes exceeding 6/12. Refer to page 122.



Typical LSSH179 installation

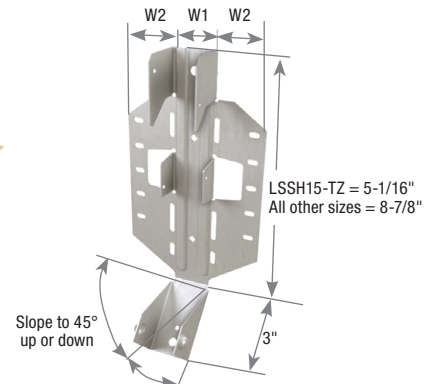

LSSH210

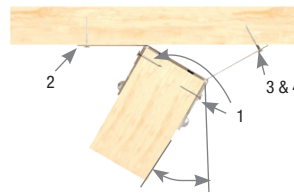

Skew to 45° maximum

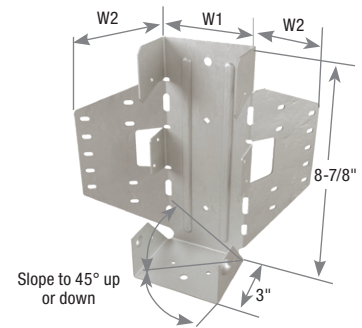

LSSH35

Rafter Width (in)	MiTek USP Stock No.	Ref. No.	Steel Gauge	Dimensions (in)		Fastener Schedule ^{2,3}				DF/SP Allowable Loads (Lbs.)				S-P-F Allowable Loads (Lbs.)				Corrosion Finish	Code Ref.
				W1	W2	Header		Rafter		Floor	Roof	Uplift ¹	160%	Floor	Roof	Uplift ¹	160%		
						Qty	Type	Qty	Type										
SLOPED ONLY HANGERS																			
1-1/2	LSSH15-TZ	LSSJ26LZ, LSSJ26RZ, LSSJ28LZ, LSSJ28RZ	18	1-9/16	1-3/4	6	10d HDG	7	10d x 1-1/2 HDG	720	820	885	565	640	730	785	440		IBC, FL, LA
1-1/2	LSSH210-TZ	LSSJ210LZ, LSSJ210RZ	18	1-9/16	1-3/4	10	10d	7	10d x 1-1/2	1200	1370	1395	410	1065	1090	1090	320		
1-3/4	LSSH179-TZ	LSSR1.81Z	18	1-13/16	1-5/8	10	10d	7	10d x 1-1/2	1200	1370	1395	880	1065	1090	1090	690		
2 - 2-1/8	LSSH20-TZ	LSSR2.1Z	18	2-1/8	2-1/2	10	10d	7	10d x 1-1/2	1200	1370	1395	795	1065	1085	1085	620		
2-1/4 - 2-5/16	LSSH23-TZ	LSSR2.37Z	18	2-5/16	2-3/8	10	10d	7	10d x 1-1/2	1200	1370	1395	795	1065	1085	1085	620		
2-1/2	LSSH25-TZ	LSSR2.56Z	16	2-9/16	2-3/4	18	16d	12	10d x 1-1/2	2095	2095	2095	945	1640	1640	1640	740		
2-5/8	LSSH26-TZ	--	16	2-11/16	2-5/8	18	16d	12	10d x 1-1/2	2095	2095	2095	945	1640	1640	1640	740		
3	LSSH31-TZ	LSSR210-2Z	16	3-1/8	3-3/4	18	16d	12	10d x 1-1/2	2645	3000	3090	1310	2345	2415	2415	1025		
3-1/2	LSSH35-TZ	LSSR410Z	16	3-9/16	3-1/2	18	16d	12	10d x 1-1/2	2645	3000	3090	1310	2345	2405	2405	1020		
SKWEDED HANGERS or SLOPED & SKWEDED HANGERS																			
1-1/2	LSSH15-TZ	LSSJ26LZ, LSSJ26RZ, LSSJ28LZ, LSSJ28RZ	18	1-9/16	1-3/4	6	10d HDG	7	10d x 1-1/2 HDG	620	620	620	510	485	485	485	400		IBC, FL, LA
1-1/2	LSSH210-TZ	LSSJ210LZ, LSSJ210RZ	18	1-9/16	1-3/4	10	10d	7	10d x 1-1/2	1200	1370	1395	880	1065	1090	1090	690		
1-3/4	LSSH179-TZ	LSSR1.81Z	18	1-13/16	1-5/8	10	10d	7	10d x 1-1/2	1200	1370	1395	880	1065	1090	1090	690		
2 - 2-1/8	LSSH20-TZ	LSSR2.1Z	18	2-1/8	2-1/2	10	10d	7	10d x 1-1/2	1200	1230	1230	795	960	960	960	620		
2-1/4 - 2-5/16	LSSH23-TZ	LSSR2.37Z	18	2-5/16	2-3/8	10	10d	7	10d x 1-1/2	1200	1230	1230	795	955	955	955	620		
2-1/2	LSSH25-TZ	LSSR2.56Z	16	2-9/16	2-3/4	14	16d	12	10d x 1-1/2	1610	1610	1610	945	1260	1260	1260	740		
2-5/8	LSSH26-TZ	--	16	2-11/16	2-5/8	14	16d	12	10d x 1-1/2	1610	1610	1610	945	1260	1260	1260	740		
3	LSSH31-TZ	LSSR210-2Z	16	3-1/8	3-3/4	14	16d	12	10d x 1-1/2	1610	1610	1610	1310	1260	1260	1260	1025		
3-1/2	LSSH35-TZ	LSSR410Z	16	3-9/16	3-1/2	14	16d	12	10d x 1-1/2	1610	1610	1610	1310	1255	1255	1255	1020		

1) Uplift loads have been increased 60% for wind or seismic loads; no further increase shall be permitted.

2) Stainless steel ring shank nails must be used with stainless steel connectors to achieve tabulated allowable loads.

3) **NAILS:** 10d x 1-1/2 nails are 0.148" dia. x 1-1/2" long, 10d nails are 0.148" dia. x 3" long, 16d nails are 0.162" dia. x 3-1/2" long.

New products or updated product information are designated in **blue font**.

Corrosion Finish

- Stainless Steel
- Gold Coat
- HDG
- Triple Zinc