



ICC-ES Evaluation Report

ESR-2266

Reissued March 2023

This report is subject to renewal March 2025.

DIVISION: 03 00 00—CONCRETE
Section: 03 16 00—Concrete Anchors

REPORT HOLDER:

MITEK® INC.

EVALUATION SUBJECT:

MITEK PROPRIETARY STB AND STBL ANCHOR BOLT SERIES CAST-IN-PLACE ANCHOR BOLTS

1.0 EVALUATION SCOPE

Compliance with the following codes:

- 2021, 2018, 2015, 2012, 2009 and 2006 *International Building Code*® (IBC)
- 2021, 2018, 2015, 2012, 2009 and 2006 *International Residential Code*® (IRC)

For evaluation for compliance with codes adopted by the Los Angeles Department of Building and Safety (LADBS), see [ESR-2266 LABC and LARC Supplement](#).

Property evaluated:

Structural

2.0 USES

MiTek proprietary STB series and STBL series cast-in-place anchor bolts are used to transfer wind- and earthquake-induced uplift forces (tension) in light-frame wood and cold-formed steel structures from their lateral force-resisting elements into their foundations. These anchor bolts may be used to transfer wind and earthquake forces (Seismic Design Categories A through F) in accordance with Section 1604.8.1 of the IBC, and may also be used to resist hold-down forces for braced walls in accordance with Section R602.10 of the 2021, 2018, 2015, and 2012 IRC; Section R602.12 of the 2009 IRC; or Section R703.7 of the 2012 and 2006 IRC, as applicable. For wall bracing applications, the allowable load capacities in this report must be used to develop allowable design capacities equal to or exceeding the required load capacity in the applicable sections of the IRC. The STB series and STBL series anchor bolts are acceptable alternatives to cast-in-place anchors described in Section 1901.3 of the 2021, 2018 and 2015 IBC, Sections 1908 and 1909 of the 2012 IBC or corresponding Sections 1911 and 1912 of the 2009 and 2006 IBC for resisting uplift forces (tension), when used in buildings of light-frame wood and cold-formed steel construction, as applicable. For

structures regulated under the IRC, the anchors may be used where an engineered design is submitted in accordance with Section R301.1.3, or may be used when approved by the building official as authorized in Section R104.1.

3.0 DESCRIPTION

3.1 General:

3.1.1 STB Series Anchor Bolt: The STB series anchor bolts are cast-in-place ductile steel anchor bolts, installed into concrete stem-walls or concrete slab foundations to transfer tensile (uplift) forces only. The anchor bolt has a 3³/₄-inch-long (95 mm), cold rolled threaded upper portion, a straight unthreaded vertical shank with an embossed embedment line, and a triple radius deformed hook at the lower (embedded) end. The rolled threads are either 7/₈ x 9 Unified National Coarse (UNC) or 5/₈ x 11 UNC compliant. The deformed hook extends several inches off the vertical axis of the shank. The STB series anchor bolt must be installed into the concrete foundation up to the embedment line to achieve the allowable tension loads shown in Table 1. These loads are transferred through the bolt and into the foundation through a combination of bond and interlocking mechanical forces between the steel and the concrete. Table 1 also provides product geometry and Figures 1 to 5 provide installation details and other relevant information. An embossed angle guide (see Figures 1, 3 and 5) is located on the top of the exposed anchor to provide easy verification of the correct orientation of the triple radius deformed hook.

3.1.2 STBL Series Anchor Bolt: The STBL series anchor bolt is identical to the STB series anchor bolt except that it has a 5¹/₂-inch-long (140 mm) threaded upper portion for use with 3-by sill plates. Load values for the STBL series anchor bolt are identical to those for the STB series.

3.2 Material:

3.2.1 STB and STBL Anchor Bolts: The STB and STBL series anchor bolts are produced from steel that conforms to the requirements in ASTM F1554 Grade 36, having a minimum yield strength of 36 ksi (248 MPa) and a minimum tensile strength of 58 ksi (400 MPa). The steel has a tensile elongation over 14 percent and an area reduction greater than 30 percent, and is classified as ductile per the requirements of Section 1.4.3 of ICC-ES AC309 and ACI 318 Chapter 2 (ACI 318 Section D.1 for the 2012, 2009, and 2006 IBC). STB and STBL Anchor Bolts are also available in a hot-dipped galvanized (HDG) finish having an average coating weight of 1.25 ounces of zinc per square foot of

surface area (381 g/m²) as prescribed for ASTM A153 Class C. This finish is indicated by the addition of "HDG" to the end of the stock number, as in STB34-HDG. The allowable load values in this report are also applicable to anchors with an HDG coating.

Anchor bolts used in contact with preservative-treated or fire-treated lumber must comply with Section 2304.10.6 of the 2021 IBC, Section 2304.10.5 of the 2018 and 2015 IBC or Section 2304.9.5 of the 2012, 2009 and 2006 IBC, Section R317.3 of the IRC, or Section R319.3 of the 2006 IRC, as applicable. The lumber treater, the report holder (MiTek), or both, must be contacted for recommendations on minimum corrosion resistance used with specific proprietary preservative-treated or fire-retardant-treated lumber.

3.2.2 Concrete Foundation: The concrete must be normal-weight and comply with the provisions of Chapter 19 of the IBC or Section R402.2 of the IRC, as applicable. The concrete must have a minimum compressive strength, f_c , of 2500 psi (17.24 MPa) and must also meet the strength (durability) requirements of Section 1904 of the IBC or Section 402.2 of the IRC, or as specified by the design professional, as applicable. Materials used to make the concrete, and the mixing and placement of the concrete, must comply with Chapter 26 of ACI 318 (Chapter 3 and Chapter 5 of ACI 318 for the 2012, 2009, and 2006 IBC), as applicable.

3.2.3 Steel Reinforcement Bars (Rebar): Steel reinforcement must be at least one No. 4 rebar and must comply with Section 20.2 of ACI 318 (Section 3.5.3 of ACI 318 for the 2012, 2009, and 2006 IBC).

4.0 DESIGN AND INSTALLATION

4.1 Design:

Allowable Stress Design (ASD) tension loads for the cast-in-place STB Series and STBL Series anchor bolts are shown in Table 1. The table reflects allowable tension loads for three different anchor locations (End Wall, Mid Wall and Corner) for wind or seismic loading conditions. Where required for compliance with 2021, 2018 and 2015 IBC Section 1905, 2012 IBC Section 1909, or 2009 and 2006 IBC Section 1912, the tabulated allowable (ASD) load values must be converted to strength design (LRFD) load values. The procedure for converting the ASD values to strength design (LRFD) values is provided in the footnotes to Table 1.

Detached one- and two-family dwellings, assigned to Seismic Design Category A, B or C, are exempt from the requirements of seismic design based on the first exception in Section 1613.1 of the IBC.

4.2 Installation:

Installation of the STB Series and STBL Series anchor bolts must be in accordance with this evaluation report and the manufacturer's published installation instructions. In the event of a conflict, this report governs.

The anchor bolts are to be installed into normal-weight concrete of continuous foundation stem walls with minimum thicknesses of, respectively, 6 inches (152 mm) and 8 inches (203 mm) for $\frac{5}{8}$ -inch-diameter (15.9 mm) anchors and $\frac{7}{8}$ -inch-diameter (22 mm) anchors. The anchor bolts may also be installed into a monolithic concrete foundation slab with an integral footing. A horizontal cold joint is not allowed within the anchor's required minimum embedment depth, unless provisions are made to transfer the load. One No. 4 steel reinforcing rebar must be installed adjacent to the anchor bolt, placed longitudinally to the stem wall, 3 to 6 inches below the top of the stem wall. It is not required to be tied to the anchor bolt but must extend a minimum

distance of $2 \times l_e$ (minimum anchor embedment) past the anchor bolt as shown in Figures 3, 4 and 5. The anchor bolts and the No. 4 steel reinforcing rebar must be secured in place to prevent movement during placement of the concrete.

The steel reinforcement in a reinforced concrete foundation may be used in lieu of the No. 4 steel reinforcing rebar provided it is located 3 to 6 inches below the top of the stem wall.

STB Series and STBL Series anchor bolts must be installed before the concrete is poured, with the lower triple radius deformed hook portion placed approximately 45 degrees from the longitudinal axis of the foundation wall. This is to be verified by the alignment indicator stamped on the exposed top end of the bolt. The anchor bolts must be embedded with the embedment line flush with the concrete surface and must have a $1\frac{3}{4}$ -inch (45 mm) minimum edge distance and a 5-inch (127 mm) minimum end distance. To achieve full tension capacity, the minimum on-center spacing of anchor bolts expected to be loaded in tension simultaneously must be equal to or greater than three times the required embedment depth for the anchor bolts. See Figures 1 to 5 for typical installation details.

4.3 Special Inspection:

Special inspections must be conducted in accordance with Section 1705.3 of the 2021, 2018, 2015, and 2012 IBC or Section 1704.4 of the 2009 and 2006 IBC, as applicable, when required by the code official. Special inspections are not required for foundations that qualify for the exceptions set forth in Section 1704.2 and Section 1705.3 of the 2021, 2018, 2015, and 2012 IBC and Section 1704.1 and Section 1704.4 of the 2009 and 2006 IBC, as applicable.

When the STB Series anchor bolts are used to resist wind forces, special inspections must be conducted in accordance with Section 1705.12 of the 2021 IBC, Section 1705.11 of the 2018 and 2015 IBC, Section 1705.10 of the 2012 IBC, Section 1706.1 of the 2009 IBC or Section 1705.4 of the 2006 IBC, as applicable. Special inspections are not required for foundations that qualify for the exceptions set forth in Sections 1704.2, 1705.12.1 and 1705.12.2 of the 2021 IBC, Sections 1704.2, 1705.11.1 and 1705.11.2 of the 2018 and 2015 IBC, Sections 1704.2, 1705.10.1 and 1705.10.2 of the 2012 IBC; Sections 1704.1, 1706.2 and 1706.3 of the 2009 IBC; or Section 1704.1 of the 2006 IBC.

When the STB Series anchor bolts are used to resist seismic forces in Seismic Design Category C, D, E or F, special inspections must be conducted in accordance with Section 1705.13 of the 2021 IBC, Section 1705.12 of the 2018 and 2015 IBC or Section 1705.11 of the 2012 IBC or Section 1707 (Special Inspections for Seismic Resistance) of the 2009 and 2006 IBC, as applicable. Special inspections are not required for foundations that qualify for the exceptions set forth in Section 1705.13.2 or Section 1705.13.3 of the 2021 IBC, Section 1705.12.2 or Section 1705.12.3 of the 2018 and 2015 IBC; Section 1705.11.2 or Section 1705.11.3 of the 2012 IBC; Section 1704.1, Section 1705.3 or Section 1707.3 of the 2009 IBC and 2006 IBC; or Section 1707.4 of the 2009 IBC.

For installations under the IRC, special inspection is not normally required. However, for an engineered design where calculations are required to be signed by a registered design professional, special inspection requirements and exemptions are as stated above, as applicable for installations under the IRC.

5.0 CONDITIONS OF USE

The MiTek STB Series and STBL Series anchor bolts described in this report comply with, or are suitable

alternatives to what is specified in, those codes listed in Section 1.0 of this report, subject to the following conditions:

- 5.1 Proprietary bolt sizes, dimensions, minimum embedment depths, spacing and edge distances are as set forth in this report.
- 5.2 Calculations showing compliance with this report must be submitted to the code official. The calculations must be prepared by a registered design professional where required by the statutes of the jurisdiction in which the project is to be considered.
- 5.3 The anchor bolts are limited to resisting tension forces only.
- 5.4 Use of the anchor bolts with preservative- or fire-retardant-treated lumber must be in accordance with Section 3.2.1 of this report.
- 5.5 Special inspection is provided in accordance with Section 4.3 of this report.

6.0 EVIDENCE SUBMITTED

Data in accordance with the ICC-ES Acceptance Criteria for Cast-in-place Propriety Bolts in Concrete for Light-frame Construction (AC399), dated February 2017 (editorially revised December 2020).

7.0 IDENTIFICATION

- 7.1 The STB and STBL series anchor bolts are identified with the letter “U” followed by a number correlating to the stock number and length (for example U28) alongside an orientation symbol indicating proper installation angle, stamped onto the exposed top of the anchor bolt. This means of identification is shown in Figure 1. The anchor bolts are shipped in cartons or containers which must be labeled with the manufacturer’s name (MiTek), the stock number, and the evaluation report number (ESR-2266).

- 7.2 The report holder’s contact information is the following:

MITEK® INC.
16023 SWINGLEY RIDGE ROAD
CHESTERFIELD, MISSOURI 63017
(800) 328-5934
www.mitek-us.com

TABLE 1—ALLOWABLE STRESS DESIGN (ASD) LOADS FOR STB and STBL SERIES CAST-IN-PLACE ANCHOR BOLTS^{1,7}

STB ANCHOR BOLT			INSTALLATION ^{2,3,4}			ALLOWABLE TENSION LOADS ^{5,6} (lbs.) BASED ON ANCHOR LOCATION:								
Model No.	Major Thread Dia. (in.)	Total Length (in.)	Min. Stem-Wall Width (in.)	H ²	Min. Anchor Embed., I _e (in.)	Continuous Concrete Foundation Stem Wall ⁶ (See Figure 3)			Corner of Concrete Foundation Stem Wall ⁶ (See Figure 4)			End of Concrete Foundation Stem Wall ⁶ (See Figure 5)		
						Seismic Design Categories		Wind	Seismic Design Categories		Wind	Seismic Design Categories		Wind
						A, B	C, D, E, F		A, B	C, D, E, F		A, B	C, D, E, F	
STB16	5/8	17 ^{13/16}	6	5	12 ^{13/16}	4,230	3,525	4,230	4,230	3,525	4,230	4,230	3,525	4,230
STBL16		19 ^{13/16}		6 ^{3/4}	12 ^{13/16}	4,230	3,525	4,230	4,230	3,525	4,230	4,230	3,525	4,230
STB20		21 ^{13/16}		5	16 ^{13/16}	5,120	4,265	5,115	4,740	3,555	4,230	4,740	3,555	4,230
STBL20		23 ^{9/16}		6 ^{3/4}	16 ^{13/16}	5,120	4,265	5,115	4,740	3,555	4,230	4,740	3,555	4,230
STB24		25 ^{13/16}		5	20 ^{13/16}	5,990	4,990	5,990	5,915	4,675	5,570	5,915	4,675	5,570
STBL24		27 ^{9/16}		6 ^{3/4}	20 ^{13/16}	5,990	4,990	5,990	5,915	4,675	5,570	5,915	4,675	5,570
STB28	7/8	31	8	5	26	10,100	7,650	9,110	9,490	7,650	9,110	9,490	7,650	9,110
STBL28		32 ^{3/4}		6 ^{3/4}	26	10,100	7,650	9,110	9,490	7,650	9,110	9,490	7,650	9,110
STB34		36		6	30	11,415	9,515	11,390	10,525	8,770	10,525	10,250	7,900	9,405
STB36		38		8	30	11,415	9,515	11,390	10,525	8,770	10,525	10,250	7,900	9,405

For SI: 1 in. = 25.4 mm, 1 lb. = 4.45 N, 1 psi = 6.895 kPa.

¹STB Series anchor bolts have 3^{3/4}-inch thread lengths. STBL Series anchor bolts have 5^{1/2}-inch thread lengths for use with 3x sill plates. One No. 4 rebar must be installed approximately 3 to 6 inches from the top of the foundation stem wall.

²H is the length of anchor bolt exposed above embedment line, used for inspection.

³Allowable loads are based on a minimum edge distance of 1^{3/4} inches and a minimum end distance of 5 inches. Per Sections 17.7 and 20.6 of ACI 318 or Sections D.8.2 and 7.7.1 of ACI 318 for the 2012, 2009 and 2006 IBC, use Hot Dip Galvanized (HDG) anchor when unprotected concrete will be exposed to earth or weather.

⁴Allowable loads are based on a minimum center-to-center spacing of 3 times minimum anchor embedment for bolts loaded simultaneously.

⁵Where required for compliance with 2021, 2018 and 2015 IBC Section 1905, 2012 IBC Section 1909, or 2009 and 2006 IBC Section 1912, the allowable (ASD) seismic or wind loads must be converted to strength design (LRFD) load values by multiplying the tabulated Allowable Stress Design (ASD) load values by 1.43 or 1.67, respectively. The tabulated ASD loads are adjusted nominal strength values and include a strength reduction factor, Φ = 0.75, for tension (uplift) loads. Consequently, when using the load combinations of 2021, 2018, 2015, and 2012 IBC Section 1605.2 or 2009 and 2006 IBC Section 1605.2.1, it is not necessary to apply a strength reduction factor, Φ, because it is already incorporated into the derived strength design (LRFD) load values.

⁶Minimum specified concrete compressive strength, f_c, must be 2,500 psi, unless required otherwise by the applicable Code.

⁷Detached one- and two-family dwellings, assigned to Seismic Design Category (SDC) A, B, or C are exempt from the requirements of seismic design per the first exception in Section 1613.1 (Scope) of the IBC.

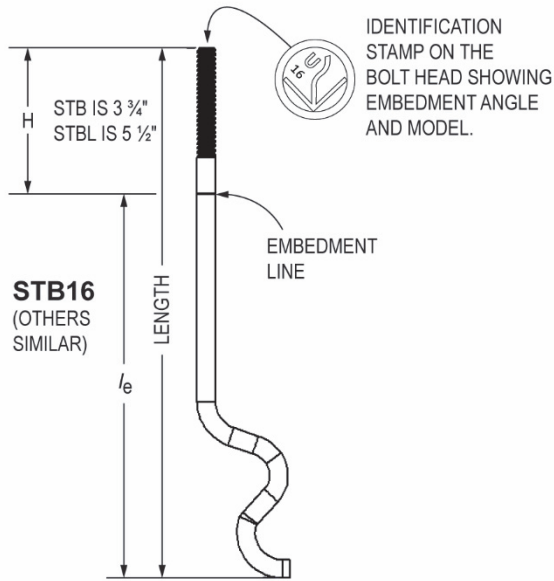

FIGURE 1 – TYPICAL STB ANCHOR BOLT
 (Identification on bolt head, minimum anchor embedment, l_e)

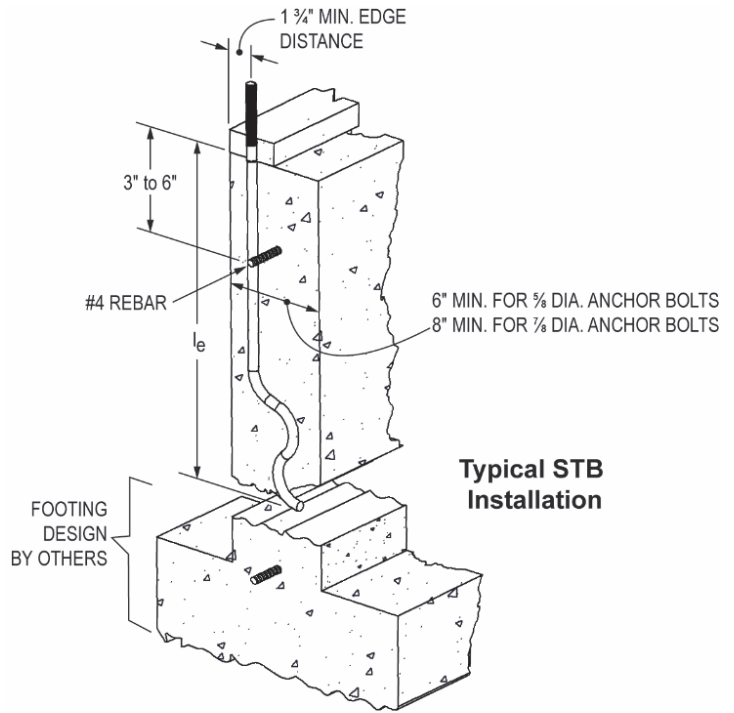

FIGURE 2 – TYPICAL STB ANCHOR BOLT INSTALLATION
 (No. 4 Rebar in Breakout Zone, Min. 1 3/4" Edge Distance)

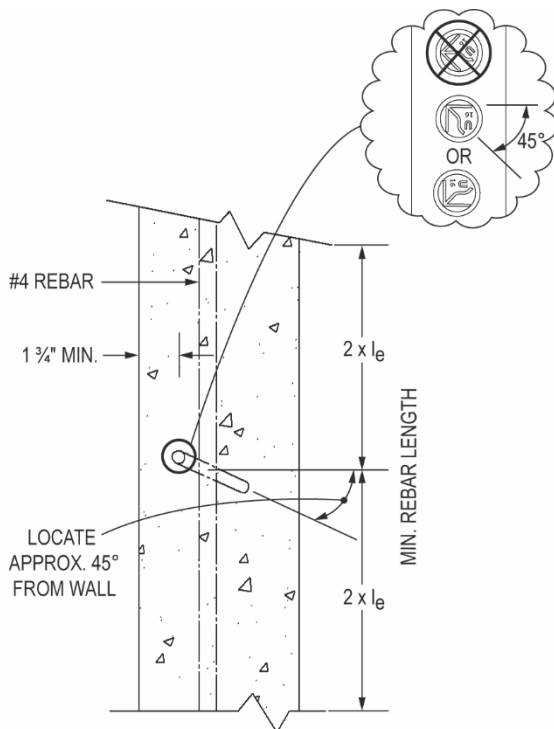

FIGURE 3 – STB ANCHOR BOLT INSTALLATION – ALONG CONTINUOUS STEM WALL
 (No. 4 Rebar Min. Length = $4 \times l_e$, Min. 1 3/4" Edge Distance)

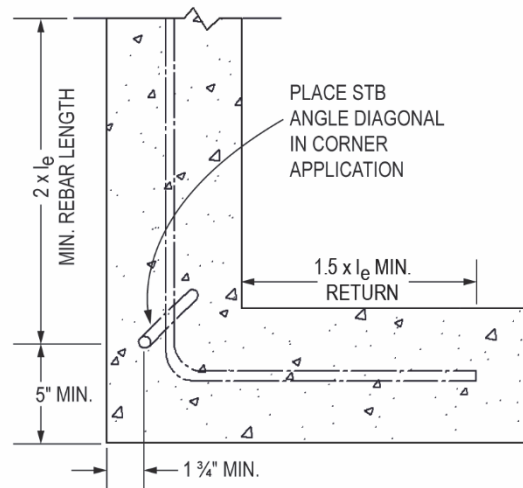
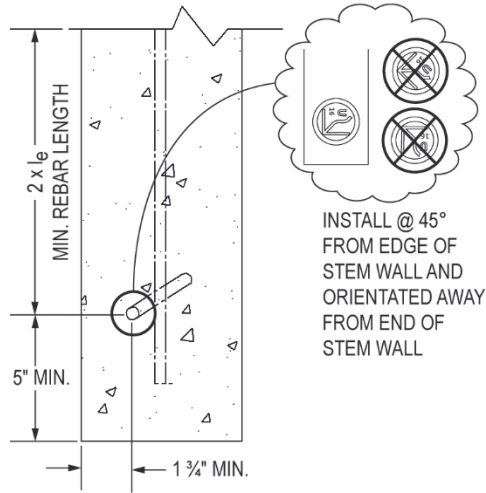

FIGURE 4 – STB ANCHOR BOLT INSTALLATION – CORNER OF STEM WALL
 (Min. 1.5 x l_e Return Rebar Length, Min. 5" End Distance)



**FIGURE 5 – STB ANCHOR
BOLT INSTALLATION –
END OF STEM WALL**
(Min. 5" End Distance, and
No. 4 Rebar Min. Length)

DIVISION: 03 00 00—CONCRETE
Section: 03 16 00—Concrete Anchors

REPORT HOLDER:

MITEK® INC.

EVALUATION SUBJECT:

MITEK PROPRIETARY STB AND STBL ANCHOR BOLT SERIES CAST-IN-PLACE ANCHOR BOLTS

1.0 REPORT PURPOSE AND SCOPE**Purpose:**

The purpose of this evaluation report supplement is to indicate that MiTek proprietary STB series and STBL series cast-in-place anchor bolts, described in ICC-ES evaluation report [ESR-2266](#), have also been evaluated for compliance with the codes noted below as adopted by the Los Angeles Department of Building and Safety (LADBS).

Applicable code editions:

- 2020 *City of Los Angeles Building Code* (LABC)
- 2020 *City of Los Angeles Residential Code* (LARC)

2.0 CONCLUSIONS

The MiTek proprietary STB series and STBL series cast-in-place anchor bolts, described in Sections 2.0 through 7.0 of the evaluation report [ESR-2266](#), comply with the LABC Chapter 19, and the LARC, and are subjected to the conditions of use described in this supplement.

3.0 CONDITIONS OF USE

The MiTek proprietary STB series and STBL series cast-in-place anchor bolts, described in this evaluation report supplement, must comply with all of the following conditions:

- All applicable sections in the evaluation report [ESR-2266](#).
- The design, installation, conditions of use and labeling are in accordance with the 2018 *International Building Code*® (IBC) provisions noted in the evaluation report [ESR-2266](#).
- The tabulated allowable loads in the evaluation report [ESR-2266](#) must not be increased for duration of loading.
- The design, installation and inspection are in accordance with additional requirements of LABC Chapter 16 and 17, as applicable.
- Under the LARC, an engineered design in accordance with LARC Section R301.1.3 must be submitted.

This evaluation report supplement expires concurrently with the evaluation report ESR-2266, reissued March 2023.

DIVISION: 03 00 00—CONCRETE
Section: 03 16 00—Concrete Anchors

REPORT HOLDER:

MITEK® INC.

EVALUATION SUBJECT:

MITEK PROPRIETARY STB AND STBL ANCHOR BOLT SERIES CAST-IN-PLACE ANCHOR BOLTS

1.0 REPORT PURPOSE AND SCOPE**Purpose:**

The purpose of this evaluation report supplement is to indicate that MiTek proprietary STB series and STBL series cast-in-place anchor bolts described in ICC-ES evaluation report ESR-2266, have also been evaluated for compliance with the codes noted below.

Applicable code editions:

- 2020 *Florida Building Code—Building*
- 2020 *Florida Building Code—Residential*

2.0 CONCLUSIONS

The MiTek proprietary STB series and STBL series cast-in-place anchor bolts, described in Sections 2.0 through 7.0 of ICC-ES evaluation report ESR-2266, comply with the *Florida Building Code—Building* and the *Florida Building Code—Residential*, provided the design requirements are determined in accordance with the *Florida Building Code—Building* or the *Florida Building Code—Residential*, as applicable. The installation requirements noted in ICC-ES evaluation report ESR-2266 for the 2018 *International Building Code*® meet the requirements of the *Florida Building Code—Building* or the *Florida Building Code—Residential*, as applicable.

Use of the MiTek proprietary STB series and STBL series cast-in-place anchor bolts have also been found to be in compliance with the High-Velocity Hurricane Zone provisions of the *Florida Building Code—Building* and the *Florida Building Code—Residential* with the following condition:

- a. For connections subject to uplift, the connection must be designed for no less than 700 pounds (3114 N).

For products falling under Florida Rule 61G20-3, verification that the report holder's quality assurance program is audited by a quality assurance entity approved by the Florida Building Commission for the type of inspections being conducted is the responsibility of an approved validation entity (or the code official when the report holder does not possess an approval by the Commission).

This evaluation report supplement expires concurrently with the evaluation report ESR-2266, reissued March 2023.