



MITEK INC.
16023 Swingley Ridge Rd.
Chesterfield, Missouri 63017
(800) 328-5934
www.mitek-us.com

MITEK® STRUCTURAL CONNECTORS FOR COLD-FORMED STEEL CONSTRUCTION

CSI Section:
05 05 23 Metal Fastenings

1.0 RECOGNITION

MiTek® structural connectors recognized in this report have been evaluated for use as cold-formed steel (CFS) framing connectors. The structural performance properties of the MiTek structural connectors comply with the intent of the provisions of the following codes and regulations:

- 2024, 2021, 2018, and 2015 International Building Code® (IBC)
- 2024, 2021, 2018, and 2015 International Residential Code® (IRC)
- 2023 City of Los Angeles Building Code (LABC) – attached Supplement
- 2023 City of Los Angeles Residential Code (LARC) – attached Supplement
- 2023 Florida Building Code®—Building – attached Supplement
- 2023 Florida Building Code®—Residential – attached Supplement

1.1 Reference Standards

The term *AISI Specification* used throughout this report refers to the reference standard for the applicable building code as follows:

- 2024 and 2021 IBC – North American Specification for the Design of Cold-Formed Steel Structural Members (S100-16(2020) w/S2-20)
- 2018 IBC – North American Specification for the Design of Cold-Formed Steel Structural Members with Supplement 1 (S100-16w/S1-18)
- 2015 IBC – North American Specification for the Design of Cold-Formed Steel Structural Members (S100-12)

2.0 LIMITATIONS

Use of the MiTek structural connectors recognized in this report is subject to the following limitations:

2.1 Connectors shall be manufactured, identified, and installed in accordance with this report and the manufacturer's published installation instructions. Where conflicts occur, the more restrictive governs. A copy of the instructions shall be available at the jobsite during installation.

2.2 Calculations showing compliance with this report shall be submitted to the building official. The calculations shall be prepared by a registered design professional where required by the statutes of the jurisdiction in which the project is to be constructed.

2.3 Adjustment factors noted in Section 3.2 of this report and the applicable codes shall be applied to allowable loads when warranted by the service conditions.

2.4 Connected steel members and fasteners shall comply, respectively, with Sections 4.2.2 and 4.2.3 of this report.

2.5 MiTek structural connectors for cold-formed steel (CFS) construction are fabricated at MiTek.

3.0 PRODUCT USE

3.1 General: The MiTek structural connectors for cold-formed steel (CFS) construction may be used as CFS framing connectors in accordance with Section 2206.1 of the 2024 IBC (Section 2211.1 of the 2021, 2018, and 2015 IBC). Holdown products in this report may also be used in structures regulated under the IRC when the corresponding tabulated Allowable Strength Design (ASD) capacity exceeds that prescribed by the IRC or when an engineered design is submitted in accordance with Section R301.1.3 of the IRC.

3.2 Design

3.2.1 General: The loads shown in Table 1 of this report for CFS members are based on Allowable Strength Design (ASD) and Load and Resistance Factor Design (LRFD) determined in accordance with the *AISI Specification*.

3.2.2 Tabulated allowable strength design (ASD) loads for the connectors in this report are based on the least value of the following criteria unless otherwise noted:

1. Average test load under which ¼-inch (6.4 mm) deflection occurs multiplied by 0.70 in accordance with AISI S913 Section 10.1.2.
2. Average peak test load, divided by a safety factor, Ω , determined in accordance with *AISI Specification* Chapter K2.
3. Allowable loads for screws used in steel-to-steel connections calculated in accordance with *AISI Specification* Section J4.

The product described in this Uniform Evaluation Service (UES) Report has been evaluated as an alternative material, design or method of construction in order to satisfy and comply with the intent of the provision of the code, as noted in this report, and for at least equivalence to that prescribed in the code in quality, strength, effectiveness, fire resistance, durability and safety, as applicable, in accordance with Section 104.2.3 of the 2024 IBC and Section 104.11 of previous editions. This document shall only be reproduced in its entirety.





3.2.3 Tabulated Load and Resistance Factor Design (LRFD) loads for the connectors in this report are based on the least value of the following criterion:

1. Average test load under which $\frac{1}{4}$ inch (6.4 mm) deflection occurs.
2. Average peak test load, multiplied by the resistance factor, ϕ , determined in accordance with *AISI Specification* Chapter K2.
3. Design strength for screws used in steel-to-steel connections calculated in accordance with *AISI Specification* Section J4.

3.3 Installation: Installation of the connectors shall be in accordance with this evaluation report and the approved plans. In the event of a conflict between this report and the approved plans, the more restrictive governs.

3.4 Special Inspection

3.4.1 A statement of special inspection shall be prepared by the registered design professional in responsible charge and submitted to the building official for approval when required by Section 1704.3 of the IBC. A statement of responsibility shall be submitted by each responsible contractor to the building official for approval when required by IBC Section 1704.4.

3.4.2 Periodic special inspection shall be conducted when connectors are components within the main wind-force resisting system of structures constructed in areas listed in 2024, 2021, and 2018 IBC Section 1705.11 or 2015 IBC Section 1705.10. Special inspection requirements do not apply to structures, or portions thereof, that qualify for an exception pursuant to 2024 and 2021 IBC Sections 1704.2, 1705.3, 1705.11, or 1705.12.2 (2018 and 2015 IBC Sections 1704.2, 1705.3, 1705.11.1, or 1705.11.2).

3.4.3 Periodic special inspection shall be conducted for seismic resistance in accordance with 2024 and 2021 IBC Section 1705.12 (2018 and 2015 IBC Section 1705.11) where required. Special inspection requirements for seismic resistance do not apply to structures, or portions thereof, that qualify for an exception pursuant to 2024 and 2021 IBC Sections 1704.2, 1705.3, 1705.13, or 1705.13.3 (2018 and 2015 IBC Sections 1704.2, 1705.3, 1705.12, or 1705.12.3).

3.4.4 For installations under the IRC, special inspection is not normally required. However, for an engineered design where calculations are required to be signed by a registered design professional, periodic special inspection requirements and exemptions are as stated in Sections 3.4.2 and 3.4.3 of this report, as applicable, for installations under the IRC.

4.0 PRODUCT DESCRIPTION

4.1 S/PHD Holdowns: S/PHD series holdowns are used to anchor CFS member(s) to foundations or to connect upper story to lower story CFS member(s) (floor-to-floor ties). The connectors are also used for anchoring concrete and masonry walls to CFS member(s) to provide lateral support for the walls in accordance with IBC Sections 1604.8.1 and 1604.8.2.

When regulated under the IRC, the hold-down connectors may also be used when their tabulated ASD load exceeds that required by IRC Section R603.9.4.2 or when an engineered design is submitted in accordance with Section R301.1.3 of the IRC.

S/PHD4 and S/PHD6 holdowns consist of pre-deflected bodies formed from No. 14 gage galvanized steel, and a base washer fabricated from No. 3 gage steel. S/PHD9 holdowns consist of pre-deflected bodies formed from No. 12 gage galvanized steel, and a base washer fabricated from No. 3 gage steel. S/PHD series holdowns use self-tapping screws to attach to the CFS member(s). Figure 1 and Table 1 of this report provide dimensions, required fasteners, and ASD and LRFD loads.

4.2 Material Information

4.2.1 Steel: Galvanized steel connector components described in this report are manufactured from steel complying with ASTM A653 SS. Non-galvanized steel connector components comply with ASTM A36. Steel used to fabricate the CFS connectors shown in this report complies with Connector Material Properties in Table 2 of this report.

Connector components fabricated from steel complying with ASTM A653 have a minimum G90 zinc coating specification. Connector components fabricated from steel complying with ASTM A36 have a hot-dipped galvanized coating with a minimum specified coating weight of 2.0 ounces of zinc per square foot of surface area (610 g/m^2), total for both sides, in accordance with ASTM A123.

4.2.2 Cold-Formed Steel Members and Structural Members: Structural cold-formed steel framing members that are attached to the connectors shown in this report shall comply with 2024 IBC Sections 2204 and 2206 (2021, 2018, and 2015 IBC Sections 2210 and 2211). Evidence shall be submitted upon the request of the building official to prove such compliance.

At a minimum, the material specification for structural cold-formed steel framing members that are attached to the connectors shown in this report shall comply with ASTM A1003. Loads in this report are based on CFS members with a minimum yield strength, F_y , of 33 ksi (228 MPa) and a minimum tensile strength, F_u , of 45 ksi (310 MPa) for



43 mil (1.09 mm) (No. 18 gage) and thinner steel and a minimum yield strength, F_y , of 50 ksi (345 MPa) and a minimum tensile strength, F_u , of 65 ksi (448 MPa) for 54 mil (1.37 mm) (No. 16 gage) and thicker steel.

Use of the connectors in this report with materials not complying with the requirements of this section is outside the scope of this report.

4.2.3 Fasteners: At a minimum, anchor bolts shall comply with ASTM F1554 Grade 36 or A307.

Self-tapping screw fasteners for connectors described in this report shall be #14 self-drilling 0.250-inch diameter hardened washer-head screws with a minimum nominal shear strength of 3,050 pounds, complying with ASTM C1513 or evaluated for compliance to the IBC in an evaluation report by IAPMO UES or another accredited evaluation service agency.

5.0 IDENTIFICATION

A label shall be affixed on at least one of the following: products, packaging, installation instructions, or descriptive literature. The label shall include the company name or trademark, model number, the name of the inspection agency (when applicable), and the Evaluation Report Number (ER-566) to identify the products recognized in this report. A die-stamp label may also substitute for the label. Either IAPMO UES Mark of Conformity may also be used as follows:

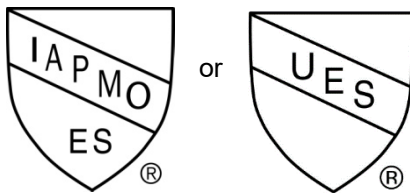

IAPMO UES ER-566

6.0 SUBSTANTIATING DATA

6.1 Data and reports of testing in accordance with AISI S905 and AISI S100.

6.2 Manufacturer's descriptive literature and installation instructions.

6.3 Reports of physical and mechanical property testing.

6.4 Test results are from laboratories in compliance with ISO/IEC 17025.

7.0 STATEMENT OF RECOGNITION

This evaluation report describes the results of research completed by IAPMO Uniform Evaluation Service on MiTek Structural Connectors for Cold-Formed Steel (CFS) Construction to assess conformance to the codes shown in Section 1.0 of this report and serves as documentation of the product certification. The product is manufactured under a quality control program with periodic inspections under the supervision of IAPMO UES.

For additional information about this evaluation report please visit www.uniform-es.org or email us at info@uniform-es.org



TABLE 1 - S/PHD HOLDOWN TENSION LOADS AND DISPLACEMENTS

MiTek Stock No.	Steel Gauge No.	Dimensions (in)				Fastener Schedule					Metal Stud Member ⁴ Mils (Gauge No.)	ASD (Lbs.)		LRFD (Lbs.)									
		W	H	D	CL	Anchor Bolt ¹		Min/Max	Stud			Tension Load	Deflection at ASD Load (in) ²	Tension Load	Deflection at LRFD Load (in) ²								
						Qty	Dia (in)		Qty	Type ³													
S/PHD4	14	2 ³ / ₈	7 ³ / ₄	3 ¹ / ₄	1 ³ / ₈	1	5 ⁸ / ₁₆	Min	6	#14	2-33 (20Ga)	2,255	0.080	3,605	0.118								
											2-43 (18Ga)	3,165	0.104	5,070	0.149								
											2-54 (16Ga)	3,955	0.132	6,330	0.188								
								S/PHD6	14	2 ³ / ₈	10 ³ / ₈	3 ¹ / ₄	1 ³ / ₈	1	5 ⁸ / ₁₆	Min	12	#14	2-33 (20Ga)	4,880	0.100	7,805	0.173
																			2-43 (18Ga)	5,525	0.105	8,840	0.161
																			2-54 (16Ga)	6,670	0.108	10,670	0.188
S/PHD9	12	2 ³ / ₈	12 ³ / ₄	3 ¹ / ₄	1 ³ / ₈	1	7 ⁸ / ₁₆									--	18	#14	2-33 (20Ga)	5,390	0.087	8,620	0.166
																			2-43 (18Ga)	6,315	0.096	10,105	0.157
																			2-54 (16Ga)	6,435	0.112	10,300	0.183
								S/PHD9	12	2 ³ / ₈	12 ³ / ₄	3 ¹ / ₄	1 ³ / ₈	1	7 ⁸ / ₁₆	--	18	#14	2-33 (20Ga)	6,495	0.096	10,390	0.154
																			2-43 (18Ga)	8,875	0.112	14,195	0.191
																			2-54 (16Ga)	10,345	0.099	16,345	0.152

For SI: 1 inch = 25.4 mm, 1 Lb. = 4.448 N

- 1) The structural designer shall specify the anchor bolt type, length, and embedment.
- 2) Deflections are derived from static, monotonic load tests and are a measurement of the displacement between the anchor bolt and a point on the cold-formed steel studs just above the holdown location. This displacement at the tabulated load includes fastener slip, holdown elongation, and elongation of an anchor bolt 4 inches in length. For every additional 1 inch in anchor bolt length, the deflection will increase 0.00010 inch (S/PHD4, S/PHD6) and 0.00006 inch (S/PHD9) for every 1,000 pounds of applied load.
- 3) #14 screws are self-drilling 0.250 inch diameter hardened washer-head screws with a minimum nominal shear strength of 3,050 pounds. See Section 4.2.3 for further information.
- 4) The structural designer shall specify the metal stud size and mil thickness.

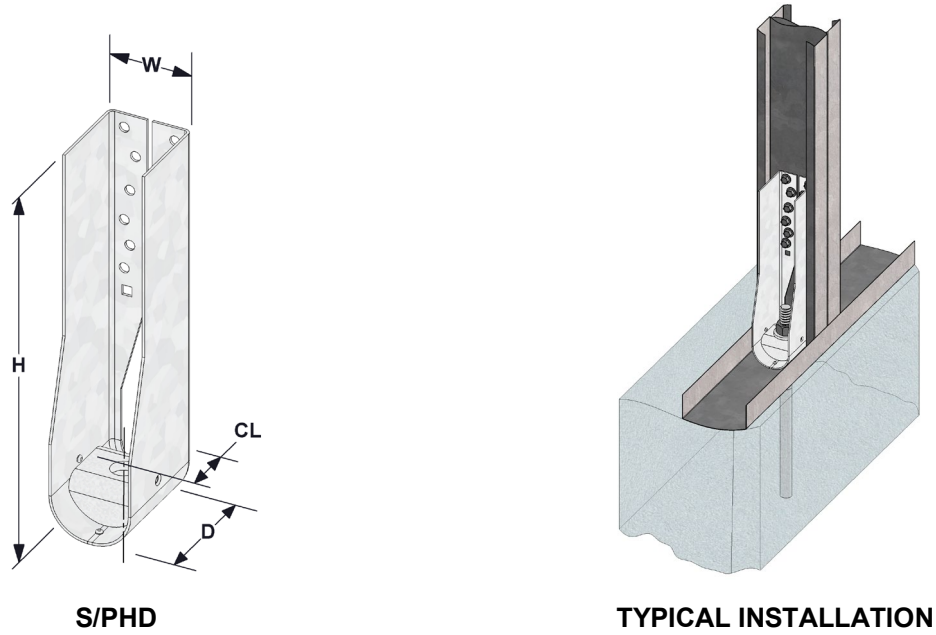

FIGURE 1 – S/PHD HOLDOWN

TABLE 2 – CONNECTOR MATERIAL PROPERTIES TABLE

Stock No.	ASTM Specification	Minimum Yield Strength F_y (ksi)	Minimum Tensile Strength F_u (ksi)	Gauge (in)	Minimum Base Metal Thickness (in)
S/PHD4 & S/PHD6 (Body)	A653 SS GR 40	40	55	14 GA.	0.070
S/PHD9 (Body)	A653 SS GR 40	40	55	12 GA.	0.099
S/PHD4 & S/PHD6, and S/PHD9 (Washer)	A36	36	58	3 GA.	0.238

For SI: 1 inch = 25.4 mm, 1 ksi = 6.895 MPa



CITY OF LOS ANGELES SUPPLEMENT

MITEK INC.
16023 Swingley Ridge Rd.
Chesterfield, Missouri 63017
(800) 328-5934
www.mitek-us.com

MITEK® STRUCTURAL CONNECTORS FOR COLD-FORMED STEEL CONSTRUCTION

CSI Section:
05 05 23 Metal Fastenings

1.0 RECOGNITION

MiTek Structural Connectors for Cold-Formed Steel (CFS) Construction described in ER-566 and this supplemental report have been evaluated for use as CFS framing connectors. MiTek Structural Connectors for CFS Construction have been evaluated for structural performance properties, subject to the requirements in ER-566 and this supplemental report. MiTek Structural Connectors for CFS Construction were evaluated for compliance with the following codes and regulations:

- 2023 City of Los Angeles Building Code (LABC)
- 2023 City of Los Angeles Residential Code (LARC)

2.0 LIMITATIONS

Use of the MiTek Structural Connectors for CFS Construction recognized in this supplement is subject to the following limitations in addition to the limitations shown in the ER-566:

2.1 For use under the 2023 LABC and LARC, the MiTek Structural Connectors for CFS Construction shall comply with the provisions applicable to the 2021 IBC and 2021 IRC as noted in ER-566.

2.2 MiTek Structural Connectors for CFS Construction shall be manufactured, identified, and installed in accordance with ER-566 and the manufacturer's published installation instructions. A copy of the installation instructions shall be available at the job site continuously during installation. If there is a conflict between this report and the manufacturer's published installation instructions, the more restrictive prevails.

2.3 Calculations verifying the compliance with ER-566 and this report supplement shall be submitted to the plan check engineer at the time of permit application. The calculations shall be prepared, stamped, and signed by a California registered design professional.

2.4 The design, installation, and inspection of MiTek Structural Connectors for CFS Construction shall be in accordance with LABC Chapters 16 and 17, as applicable, due to local amendments to these chapters.

2.5 This supplement expires concurrently with ER-566.

For additional information about this evaluation report please visit www.uniform-es.org or email us at info@uniform-es.org



FLORIDA SUPPLEMENT

MITEK INC.

16023 Swingley Ridge Rd.
Chesterfield, Missouri 63017
(800) 328-5934
www.mitek-us.com

MITEK® STRUCTURAL CONNECTORS FOR COLD-FORMED STEEL CONSTRUCTION

CSI Section:

05 05 23 Metal Fastenings

1.0 RECOGNITION

MiTek Structural Connectors for CFS Construction evaluated and represented in IAPMO UES Evaluation Report ER-566 and with changes as noted in this supplement are satisfactory alternatives for use in buildings built under the following codes (and regulations):

- 2023 Florida Building Code®—Building
- 2023 Florida Building Code®—Residential

MiTek Structural Connectors for CFS Construction have also been evaluated for and found to be in compliance with the High-Velocity Hurricane Zone provisions of the Florida Building Code®—Building and Florida Building Code®—Residential.

2.0 LIMITATIONS

MiTek Structural Connectors for CFS Construction recognized in IAPMO UES ER-566 and this supplement are subject to the following additional limitations:

2.1 Design requirements shall be determined in accordance with the Florida Building Code®—Building or Florida Building Code®—Residential, as applicable.

2.2 Use and installation of MiTek Structural Connectors for CFS Construction shall be in accordance with the 2021 International Building Code® provisions of IAPMO UES ER-566, unless otherwise noted in this supplement.

2.3 Verification that the report holder's quality assurance program is audited by a quality assurance entity approved by the Florida Building Commission (or the building official when the report holder does not possess an approval by the Commission), to provide oversight and determine that the products are being manufactured as described in this evaluation report to establish continual product performance shall be provided for products falling under Section (5)(d) of Florida Rule 61G20-3.008.

2.4 This supplement expires concurrently with ER-566.

For additional information about this evaluation report please visit www.uniform-es.org or email us at info@uniform-es.org