

PAF post anchors are used to secure wood posts to concrete footings. These one-piece post anchors also provide moisture damage protection and feature a 1" stand-off plate to elevate wood posts above concrete surfaces as required by building code. PAF post anchors come in models suitable for 4x4, 4x6 and 6x6 nominal lumber posts.

**Materials:** 14 gauge

**Finish:** G-185 galvanizing

**Codes:** ESR-3449, FL17239, LABC

**Options:** PAF44, PAF46 and PAF66 are available in Gold Coat finish. To order, add "-GC" to end of stock number, as in PAF44-GC

**Installation:**

- Install the required fasteners according to the table.
- Anchor bolts, washers and nuts are not supplied with the PAF Post Anchors.
- Anchor bolt installation – place specified diameter anchor bolt at desired location with minimum 4" embedment into minimum 2,500 psi concrete. A minimum 2" edge distance from the outermost edge of the post base to the edge of the concrete is required to achieve allowable loads. Tighten the anchor bolt to PAF base with nut and washer.
- **For cured concrete or retrofit installations** – use specified diameter threaded rod with adhesive epoxy, following manufacturer's installation instructions.
- **Not recommended for fence posts or other unrestrained (not fixed or fastened at top) applications. These anchors are not designed to resist overturning (moment) loads.**

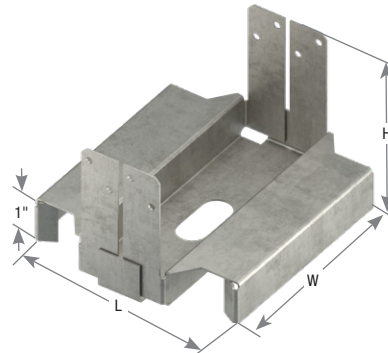

PAF

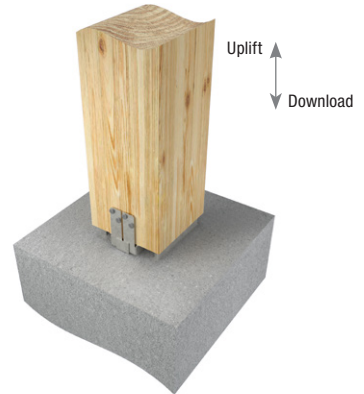

Typical PAF installation

AVAILABLE IN  
**GOLD  
COAT**

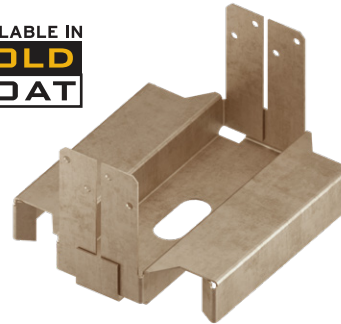

PAF66-GC

Post/ Column Size	MiTek Stock No.	Ref. No.	Steel Gauge	Dimensions (in)			Fastener Schedule <sup>3</sup>				DF/SP Allowable Loads (Lbs.) <sup>1</sup>		Ctn Qty
				W	H	L	Anchor Bolt		Post		Bearing 100%	Uplift <sup>1</sup> 160%	
							Qty	Dia. (in)	Qty	Type			
4 x 4	PAF44-TZ	ABA44Z	14	3-11/16	2-11/16	3-5/16	1	1/2	8	10d HDG	7245	810	10
4 x 6	PAF46-TZ	ABA46Z	14	3-11/16	3-1/4	4-15/16	1	5/8	8	10d HDG	8490	1365	10
										16d HDG	8835		
6 x 6	PAF66-TZ	ABA66Z	14	5-11/16	3-1/4	4-15/16	1	5/8	8	10d HDG	10870	1375	5
										16d HDG	12040		

1) Uplift loads have been increased 60% for wind or seismic loads; no further increase shall be permitted.

2) The PAF device is anchored to the concrete or masonry surface with the specified diameter anchor bolt listed with a cut washer (furnished by others).

3) **NAILS:** 10d nails are 0.148" dia. x 3" long, 16d nails are 0.162" dia. x 3.5" long.