

# HIGH WIND RESISTANCE CONSTRUCTION GUIDE



## VALUES FOR DOUGLAS FIR – LARCH (DF)

### *Continuous Load Path*

Research and field investigations have proven wood frame buildings fail at connection points.

Wood buildings can survive high wind loads when structurally rated and tested lumber connectors are used to develop a continuous load path, effectively transferring loads from roof to foundation. This guide illustrates structurally-rated products

manufactured by MiTek, to aid the designer in achieving continuous load paths. All load values published in this guide are at a 1.6 load duration factor. Refer to the **MiTek Product Catalog** or appropriate code evaluation reports for nail schedules, installations, and product information at [MITek-US.com](http://MITek-US.com).

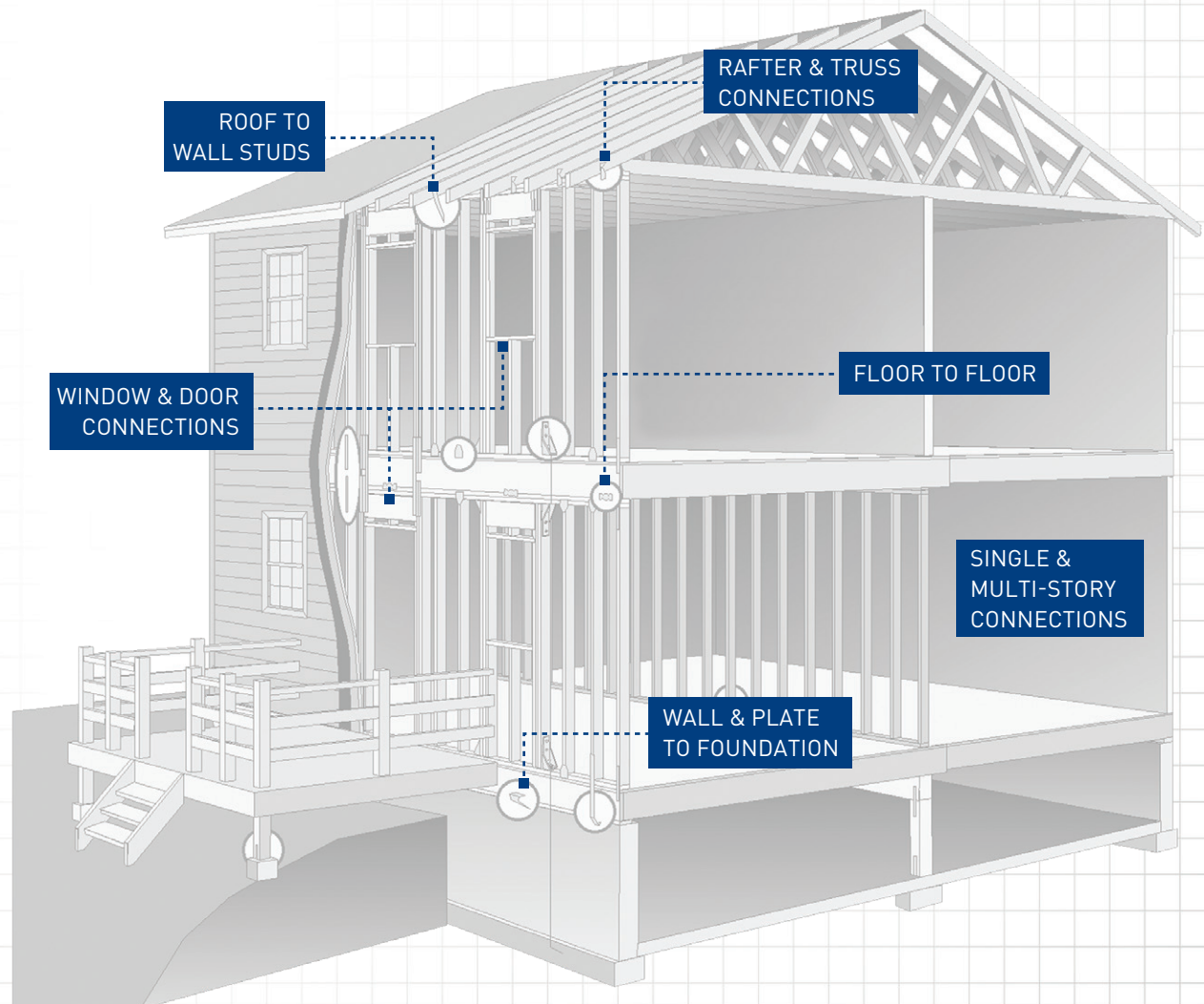

# MiTek<sup>®</sup>

1-800-328-5934  
MiTek-US.com

©2021 MiTek Industries, Inc. All Rights Reserved. #704-03/2021

# FOUNDATION CONNECTIONS

## FOUNDATION OUTSIDE VIEW

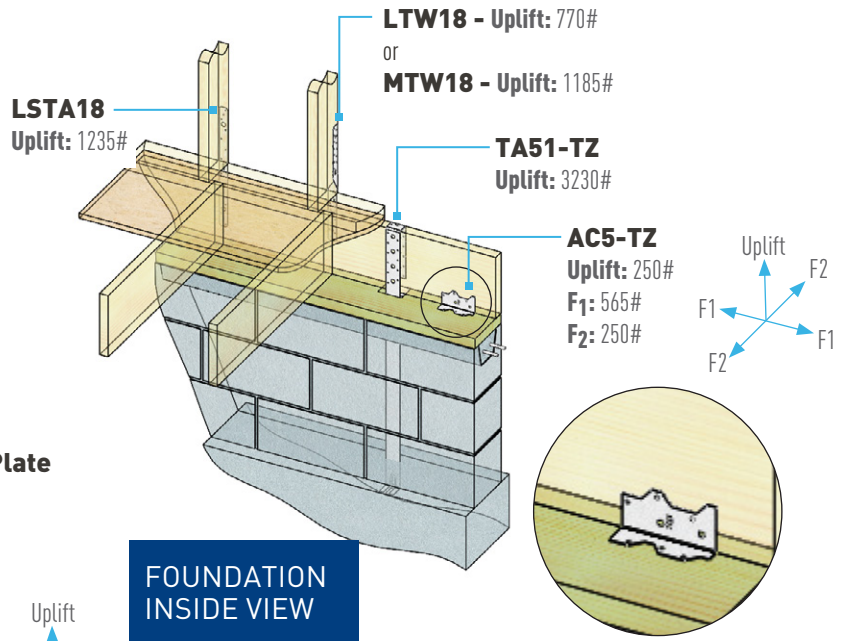
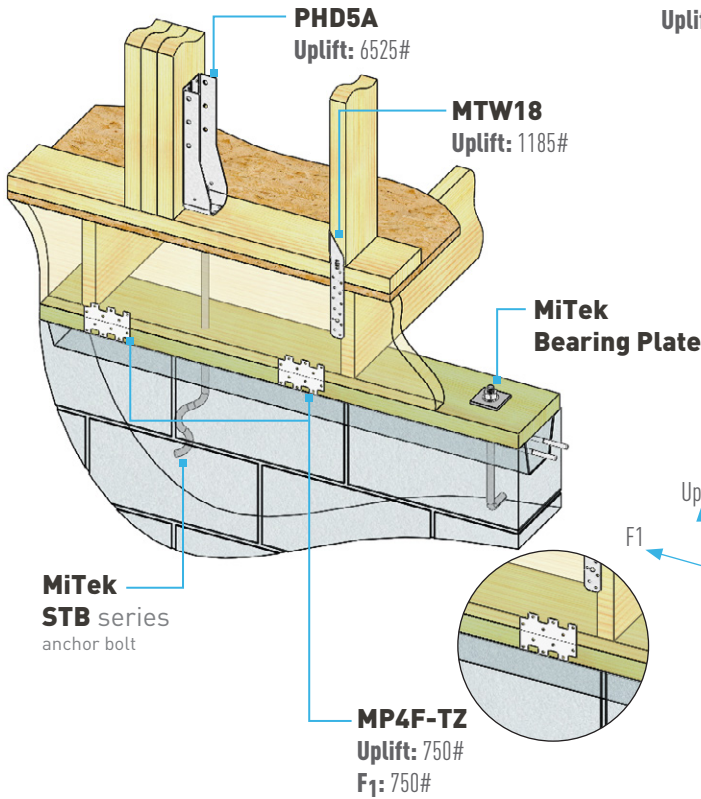

## MONO CONCRETE SLAB

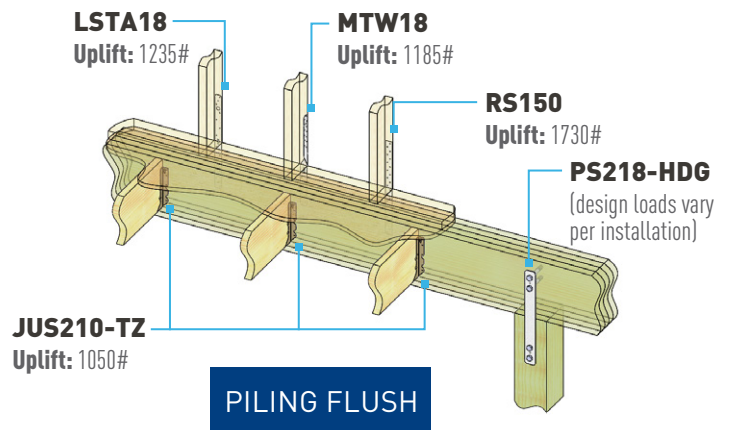
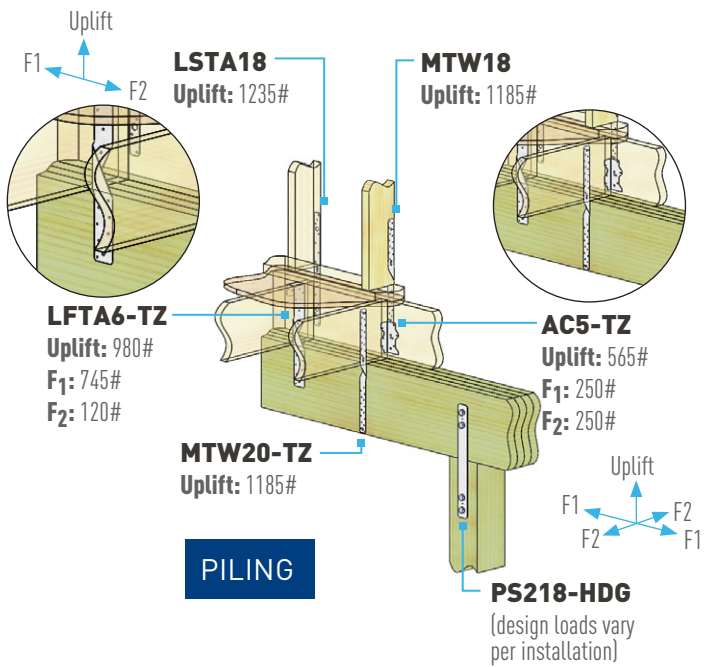
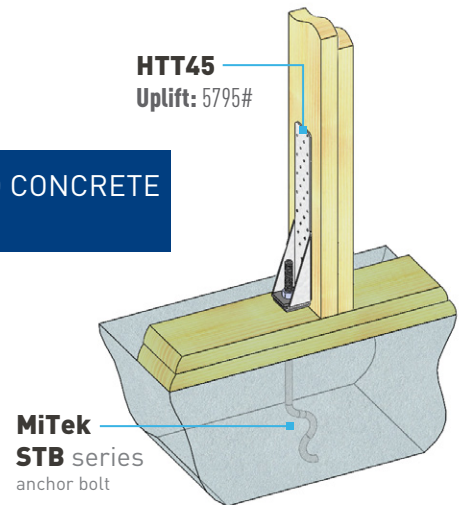

Reference MiTek's current Product Catalog for alternate fastener schedules, allowable loads, or installation options. Contact MiTek Customer Service for further assistance.

# RAFTER AND TRUSS CONNECTIONS

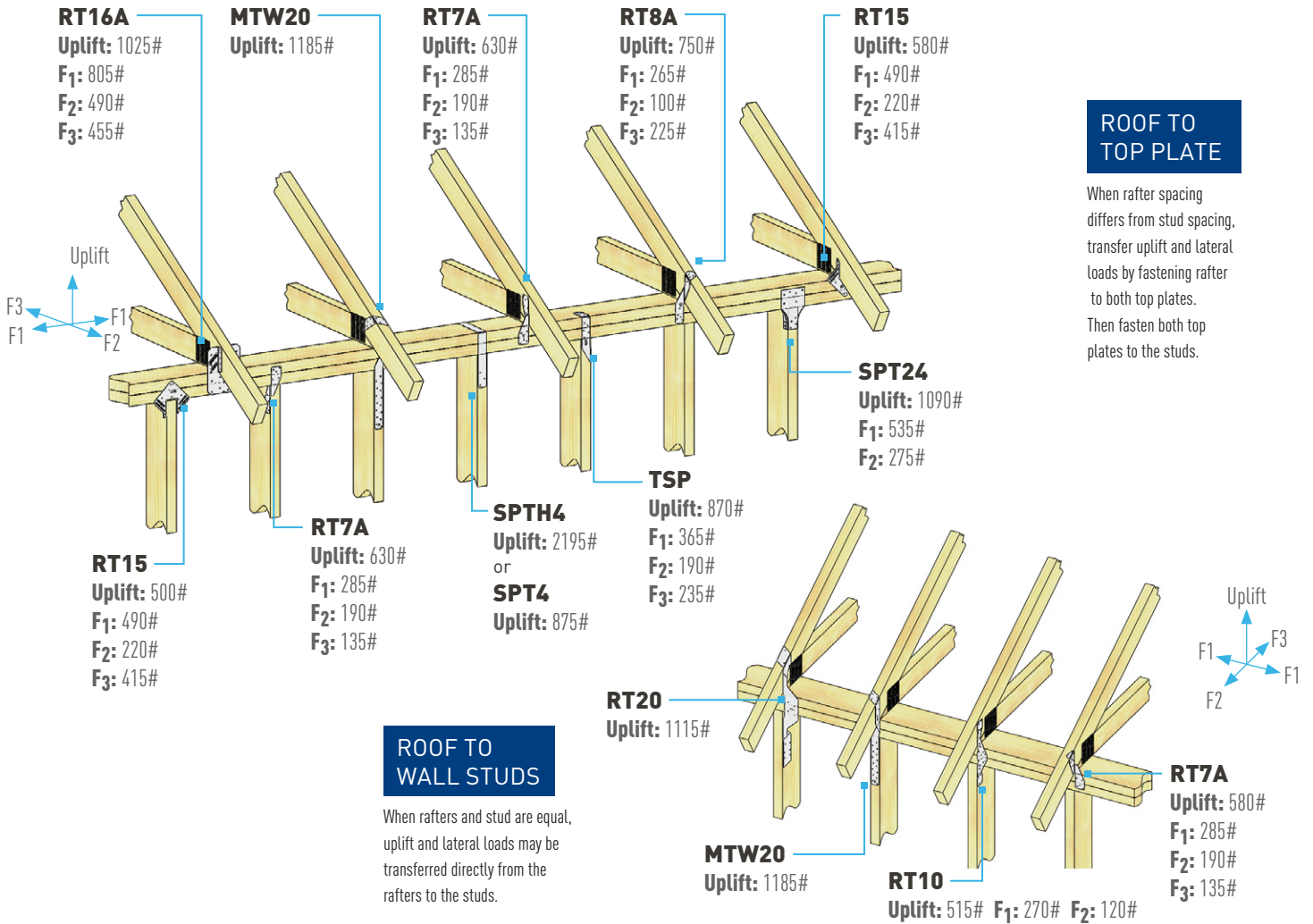

# MASONRY WALLS TO RAFTER OR TRUSS

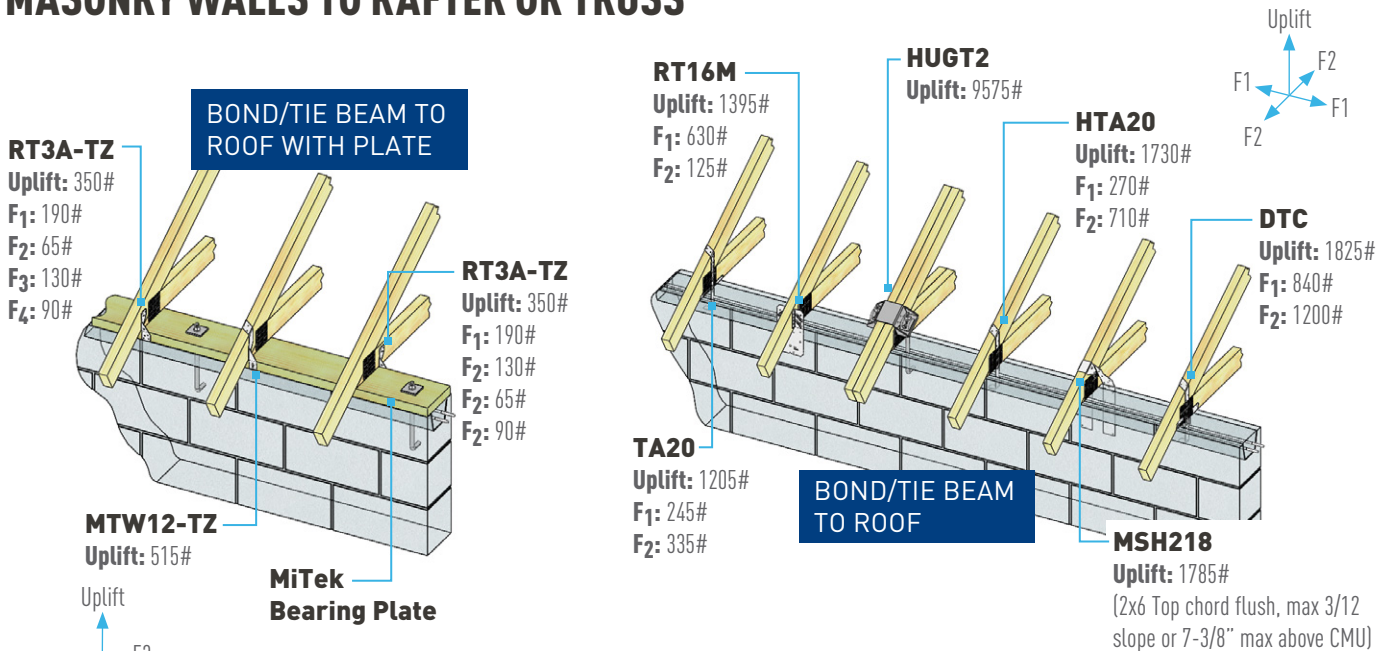

For fastener schedules, installation, and load information to masonry walls refer to MiTek's Masonry Application Technical Bulletins: [Mitek-US.com/resources/product/technical-bulletins-masonry-application/](http://Mitek-US.com/resources/product/technical-bulletins-masonry-application/)

Reference MiTek's current Product Catalog for alternate fastener schedules, allowable loads, or installation options. Contact MiTek Customer Service for further assistance.



# MULTI-STORY CONNECTIONS

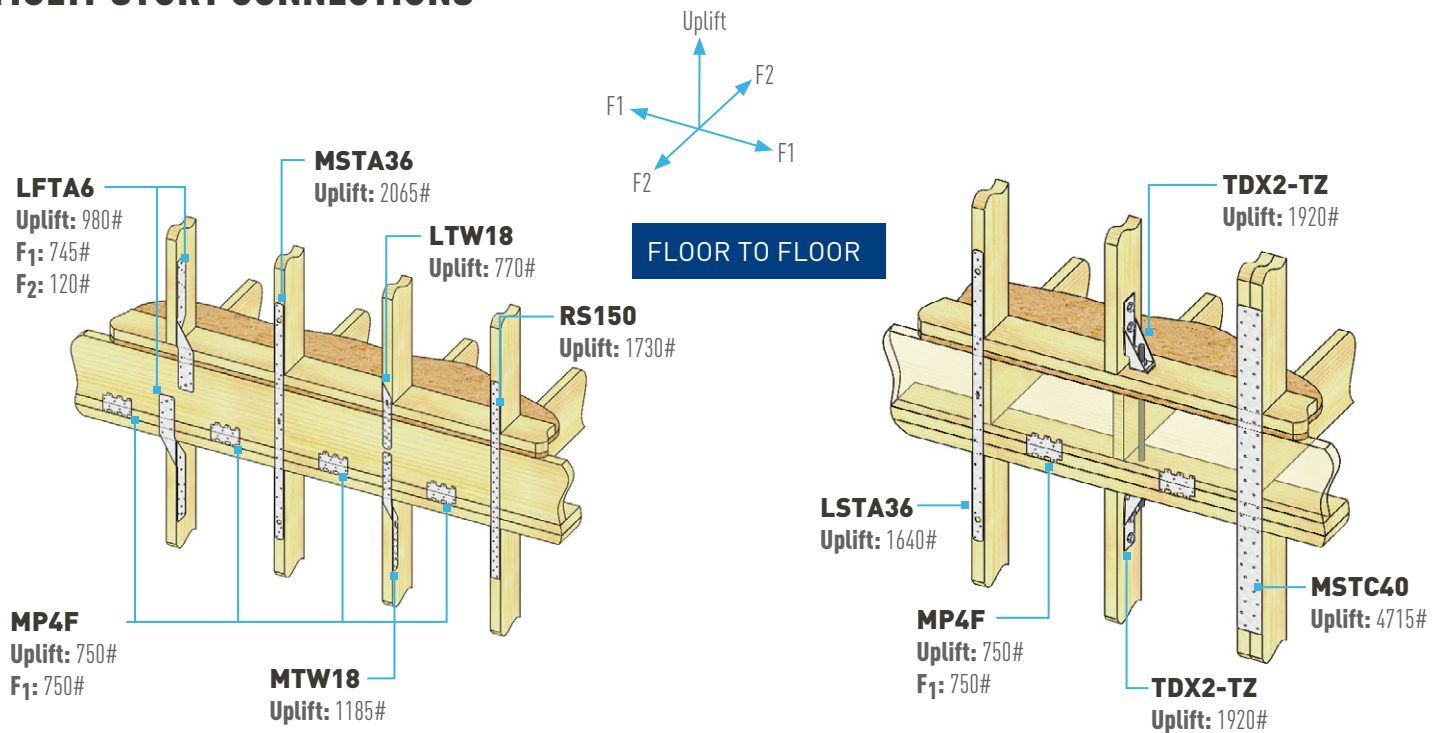

# WINDOW AND DOOR OPENINGS

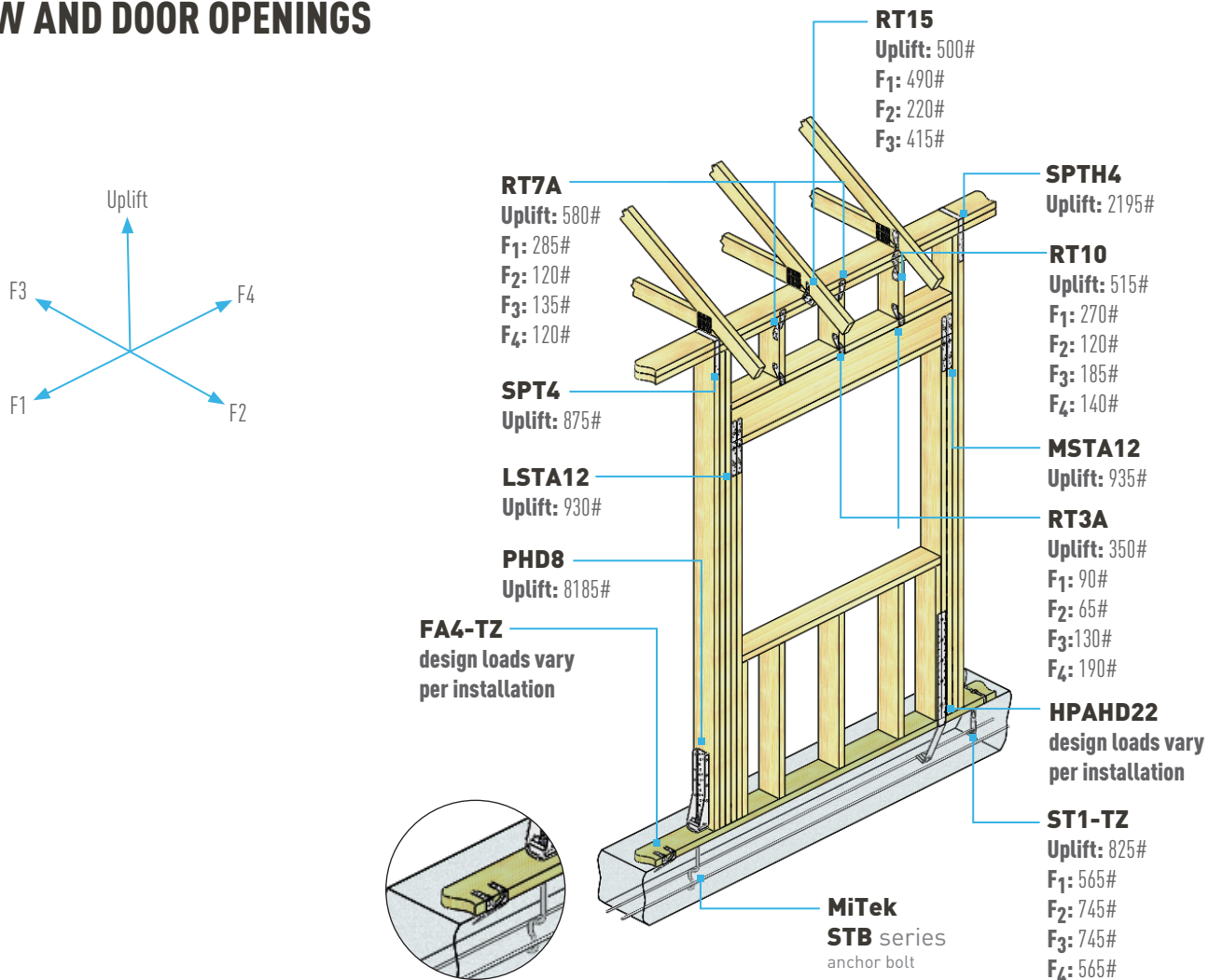

Reference MiTek's current Product Catalog for alternate fastener schedules, allowable loads, or installation options. Contact MiTek Customer Service for further assistance.

# SINGLE-STORY WOOD FRAME (TO TRUSS)

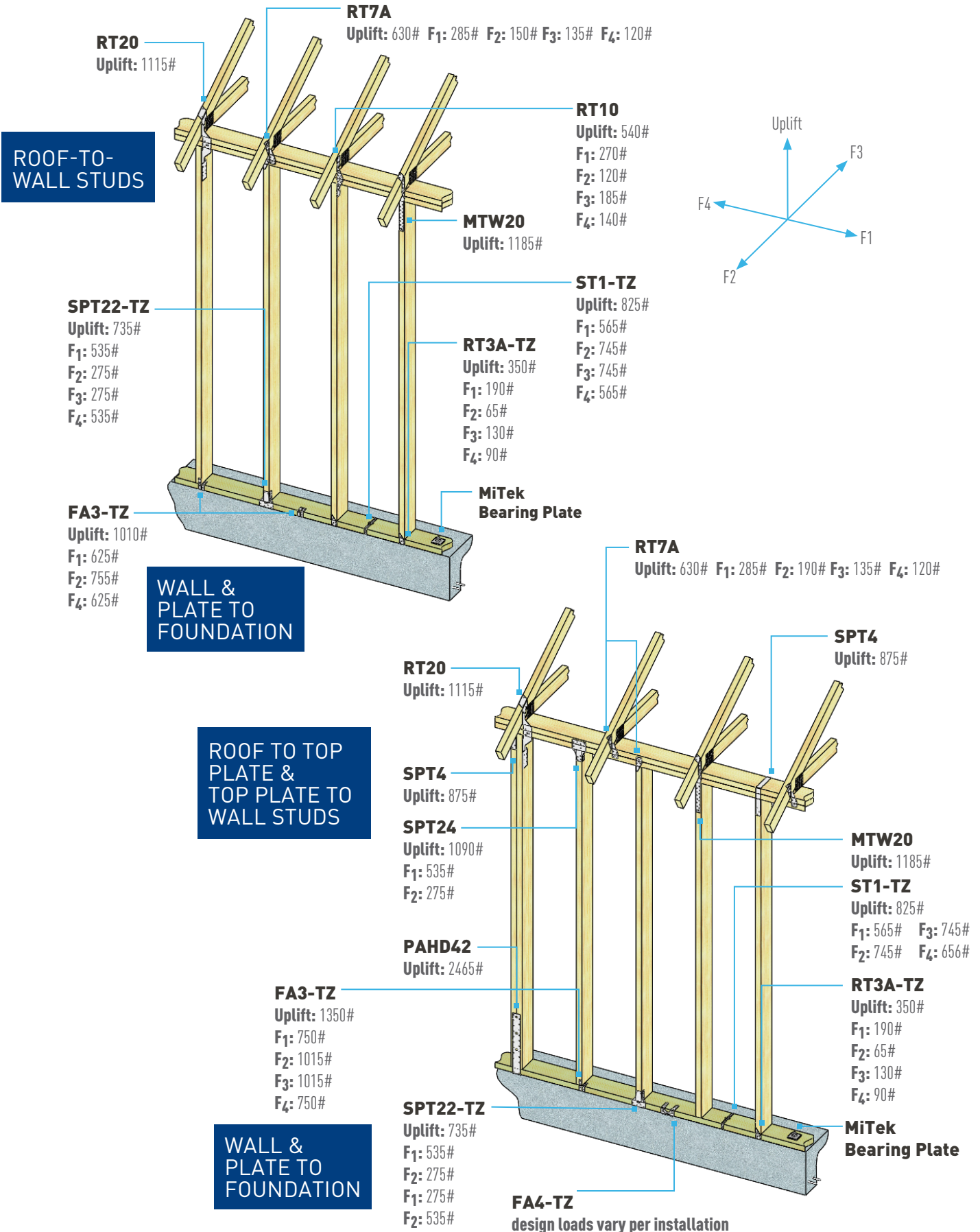

Reference MiTek's current Product Catalog for alternate fastener schedules, allowable loads, or installation options. Contact MiTek Customer Service for further assistance.

# RAFTER TO PLATE OR RIDGE CONNECTIONS

## RIDGE RAFTER TIEDOWN

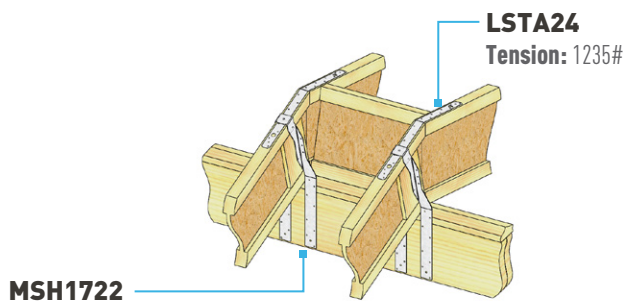

As shown for 1-3/4" wide joist.  
A different MSH hanger may be required depending on rafter width.

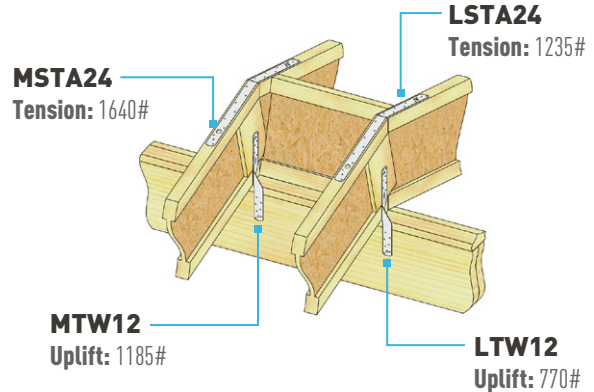

## RAFTER TO RIDGE BEAM

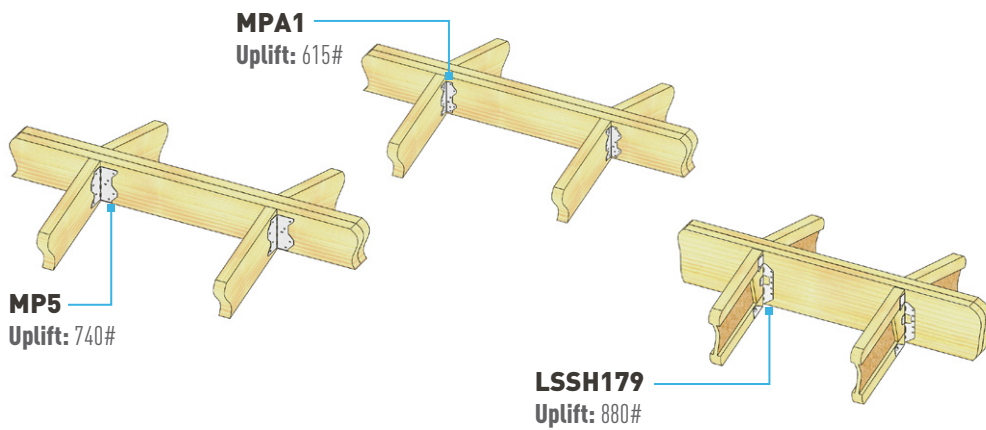

## RAFTER-TO-WALL

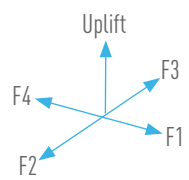
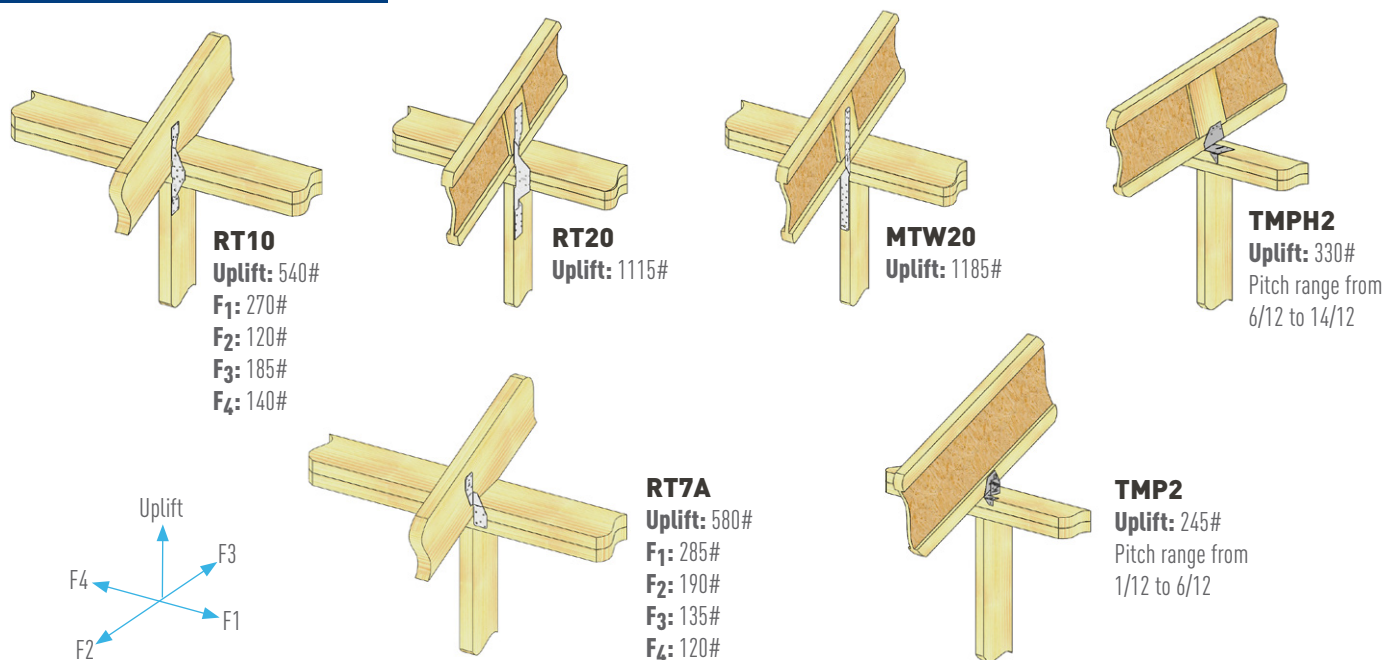

Reference MiTek's current Product Catalog for alternate fastener schedules, allowable loads, or installation options.  
Contact MiTek Customer Service for further assistance.