



ICC-ES Evaluation Report

ESR-3754

Reissued September 2021

This report is subject to renewal September 2022.

DIVISION: 03 00 00—CONCRETE
Section: 03 16 00—Concrete Anchors

DIVISION: 06 00 00—WOOD, PLASTICS, AND COMPOSITES
Section: 06 05 23—Wood, Plastic, and Composite Fastenings

REPORT HOLDER:

MITEK® INC.

EVALUATION SUBJECT:

MITEK COLUMN BASES EMBEDDED IN CONCRETE

1.0 EVALUATION SCOPE

Compliance with the following codes:

- 2021, 2018, 2015 and 2012 *International Building Code*® (IBC)
- 2021, 2018, 2015 and 2012 *International Residential Code*® (IRC)

For evaluation for compliance with codes adopted by Los Angeles Department of Building and Safety (LADBS), see [ESR-3754 LABC and LARC Supplement](#).

Property evaluated:

Structural

2.0 USES

The MiTek column bases described in this report are connectors used to transfer downward, uplift and lateral loads from wood columns or posts to concrete foundations, in accordance with IBC Section 1604.8.1, and are alternatives to the cast-in-place concrete anchors addressed in IBC Section 1901.3 (2012 IBC Sections 1908 and 1909). They may also be used to separate untreated lumber posts from concrete foundations to address IBC Section 2304.12.2.2 (Section 2304.11.2.7 for the 2012 IBC). The column bases may also be used under the IRC in accordance with Sections R301.1.3, R317.1, and R407.3.

3.0 DESCRIPTION

3.1 Column Bases:

The MiTek column bases are cold-formed steel devices which are partially embedded in cast-in-place concrete and connected to wood columns or posts using fasteners.

3.1.1 WAS Wet Post Anchor: The WAS Wet Post Anchor is a two piece anchor used to attach nominal 4-by-4, 4-by-6, and 6-by-6-inch sawn lumber wood posts to cast-in-place concrete. It is designed to provide download, lateral and uplift resistance in cracked and uncracked concrete. The anchor provides a one-inch standoff between the post and the concrete, with the bottom of the support stand installed flush with the surface of the concrete. The WAS anchor consists of a U-shaped stirrup (straps) and a support stand. The support stand is riveted to the stirrup at the manufacturing facility. The straps for these connectors are manufactured from either 12- or 14-gage, ASTM A653 SS Grade 40 galvanized steel, and the support stand is manufactured from 12- or 16-gage ASTM A653 SS Grade 40 galvanized steel, both with a minimum yield strength of 40 ksi. The WAS anchor straps are pre-punched with holes for use with 16d common nails and 1/2-inch-diameter bolts. See Table 1 for product dimensions, applicable post size, required fasteners and allowable loads. See Figure 1 for illustrations of the anchor, its typical installation, and load orientations corresponding to the allowable loads in Table 1.

3.1.2 WE Wet Post Anchor: The WE Wet Post Anchor is a one-piece anchor used to attach nominal 4-by-4, 4-by-6, and 6-by-6 sawn lumber wood posts to cast-in-place concrete. It is designed to provide lateral and uplift resistance in cracked and uncracked concrete. The WE anchor is manufactured from 12-gage, ASTM A653 SS Grade 40 galvanized steel, with a minimum yield strength of 40 ksi. The WE is pre-punched for 16d common nails and 1/2-inch-diameter bolts. See Table 2 for product dimensions, applicable post sizes, required fasteners, and allowable loads. See Figure 2 for illustrations of the column bases, typical installation, and load orientations corresponding to the allowable loads in Table 2.

3.1.3 EPB/EBG Elevated Post Base: The EPB/EBG Elevated Post Bases are two-piece anchors used to attach nominal 4-by-4, 4-by-6 and 6-by-6 sawn lumber wood posts to cast-in-place concrete. They are designed to provide download, lateral and uplift resistance in cracked and uncracked concrete. The post base allows a maximum one-inch standoff between the post and the concrete.

The EPB Elevated Post Base consists of a 12-gage ASTM A1011 Grade 40 steel bucket welded to an ASTM A513 Type 1021 Grade 40 round steel tube with an outside diameter of 1.25 inches (32 mm) and a wall thickness of 0.070 inch (2 mm). It is painted with a corrosion resistant primer after fabrication.

The EBG Elevated Post Base consists of a 14-gage ASTM A653 SS Grade 40 steel bucket crimped to a 16-gage ASTM A500 Grade B round steel tube with an outside diameter of 1.00 inches (25 mm) and a wall thickness of 0.055 inch (1.4 mm). It is painted with a corrosion resistant primer after fabrication.

See Table 3 for product dimensions, applicable post size, required fasteners and allowable loads. See Figure 3 for illustrations of the post bases, typical installation, and load orientations corresponding to the allowable loads in Table 3.

3.1.4 CBE Column Base: The CBE Column Base is a two-piece anchor used to attach nominal 4-by-4, 4-by-6, and 6-by-6 sawn lumber wood posts to cast-in-place concrete. It is designed to provide uplift resistance in cracked and uncracked concrete. The anchor consists of a U shaped stirrup (straps) with a flat base plate welded to the straps. The stirrup is embedded into the concrete so that the base plate is installed flush with the surface of the concrete. The straps and the base plate are manufactured from 12-gage ASTM A653 SS Grade 40 galvanized steel with a minimum yield strength of 40 ksi. The CBE straps are pre-punched with holes for use with 16d common nails and 1/2-inch-diameter bolts. See Table 4 for product dimensions, applicable post size, required fasteners, and allowable loads. See Figure 4 for illustrations of the connector, its typical installation in a concrete slab, and load orientations corresponding to the allowable loads in Table 4. When installed in a concrete pier, the minimum pier size must be 8 inches square and the pier must be reinforced with a minimum of two No. 5 reinforcing bars placed vertically at opposite corners. Larger pier dimensions may be required to provide concrete protection in accordance with the applicable codes.

3.1.5 EPB44T-TZ Elevated Post Base: The EPB44T-TZ elevated post base is a two-piece anchor used to attach nominal 4-by-4 posts to either cast-in-place concrete or a preformed concrete pier block. It is designed to provide download and uplift resistance in uncracked concrete. The base consists of a 5/8-inch-diameter ASTM A307 Grade C galvanized threaded rod and a 12-gage ASTM A653 SS Grade 40 galvanized steel bucket. The threaded rod component of the anchor is preset to provide a maximum height of 2 1/2 inches between the post and the concrete, eliminating direct post-to-concrete contact and providing adjustable base height to accommodate site conditions. A minimum embedment depth of 2 1/2 inches is maintained by a 1 3/4-inch ASTM F844 galvanized washer and a 1/2-inch ASTM A536 Grade C galvanized nut. The threads of the threaded rod are indented at the 2 1/2-inch mark to prevent the nut-washer from moving past this point. See Table 5 for product dimensions, applicable post size, required fasteners, and allowable loads. See Figure 5 for illustrations of the anchor, its typical installation in cast-in-place concrete, and load orientations corresponding to the allowable loads in Table 5.

3.2 Materials:

3.2.1 Connector Steel: The specific types of steel for each product are described in Sections 3.1.1 through 3.1.5. Products designated by TZ have a G185 galvanized coating in accordance with ASTM A653. All other products are protected by a minimum G90 galvanized coating or corrosion resistant primer. Minimum base-steel thicknesses for the different gages are shown in the following table:

GAGE NO.	MINIMUM BASE STEEL THICKNESS (inch)
16	0.055
14	0.070
12	0.099

For SI: 1 inch = 25.4 mm.

3.2.2 Wood: Wood members must be sawn lumber with a minimum equivalent specific gravity of 0.50 for fastener design. For connectors installed with nails, the thickness of the wood member must be sufficient such that the specified fasteners do not protrude through the opposite side of the member.

3.2.3 Fasteners: Required fastener types and sizes specified in Tables 1 through 5 for use with the column bases must be as described in this section. Nails used in contact with preservative-treated or fire-retardant-treated lumber must be hot-dipped galvanized carbon steel nails. Nails of other materials or finishes may be used when they are evaluated in an ICC-ES evaluation report for use in the applicable treated lumber. Bolts used in contact with preservative-treated or fire-retardant-treated wood must comply with IBC Section 2304.10.6 (2304.10.5 for the 2018 and 2015 IBC and 2304.9.5 for the 2012 IBC) and IRC Section R317.3, as applicable.

3.2.3.1 Bolts: At a minimum, bolts must comply with ASTM A307 and must have a minimum bending yield strength of 45,000 lbf/in² (310 MPa). Bolt diameters must be as specified in the applicable tables of this report.

3.2.3.2 Nails: The 10d and 16d common nails specified in the tables for use with the column bases must be bright carbon or galvanized carbon steel complying with ASTM F1667 including the requirements of Section S1 of ASTM F1667. Alternatively, nails of other materials or finishes may be used when they are evaluated in an ICC-ES evaluation report as having bending yield strength and withdrawal capacity equal to or greater than those of a bright carbon steel nail of the same nominal diameter.

3.2.4 Concrete: Concrete must be normal-weight concrete complying with the provisions of IBC Chapter 19 or IRC Section R402.2, as applicable. The allowable loads in the tables in this report are based on a minimum specified concrete compressive strength, f'_c , of 2500 psi (17.2 MPa).

4.0 DESIGN AND INSTALLATION

4.1 Design:

4.1.1 General: Allowable loads for the Column Bases in this report are shown in Tables 1 through 5 and are based on allowable stress design (ASD). Methods for converting the allowable loads to design strengths for use in LRFD are addressed in the footnotes to the tables.

4.1.2 Load Duration: Allowable uplift and lateral loads include the load duration factor (C_D) corresponding with wind and earthquake loading ($C_D = 1.6$) in accordance with the AWC *National Design Specification® for Wood Construction* (NDS). Allowable download loads are based on normal duration of load ($C_D = 1.0$). When used with the load combinations in IBC Section 1605.1 (2018, 2015, and 2012 IBC Section 1605.3), no increases in the allowable loads are allowed.

4.1.3 Moisture Content: Tabulated allowable loads are for connections in wood seasoned to a maximum moisture content of 19 percent used under continuously dry conditions. When connectors are installed using nails or bolts, in wood having a moisture content greater than 19 percent, or where the in-service moisture content is

expected to exceed this value, the wet service factor, C_M , must be applied, as specified in the NDS for lateral loading of dowel-type fasteners.

4.1.4 Temperature: Tabulated allowable loads are for connections and where sustained temperatures are limited to 100°F (37.8°C) or less. When connectors are installed in wood that will experience sustained exposure to temperatures exceeding 100°F (37.8°C), the allowable loads in this evaluation report must be adjusted by the temperature factor, C_t , specified in the NDS.

4.1.5 Wood and Concrete Members: The allowable loads shown in Tables 1 through 5 are based on the strength of the connection of the wood to the connector, the strength of the connector itself, and the anchorage capacity of the connector in the concrete. Design of the wood members and concrete members to which the connectors are attached is outside the scope of this report, including the analysis of the wood member stresses at the connection in accordance with Section 11.1.2 of the 2018 and 2015 NDS for the 2021, 2018, and 2015 IBC and IRC, as applicable (Section 10.1.2 of the 2012 NDS for the 2012 IBC and IRC). The connection of the wood member to the concrete must be considered to be a pinned (not fixed) connection. Use of the column bases to resist moments is outside the scope of this report.

4.2 Installation:

Installation of the column bases and the connected wood posts or columns must be in accordance with this report, the column base manufacturer's published installation instructions and the approved plans. In the event of a conflict amongst these documents, the most restrictive requirements govern.

The column bases addressed in this report may be cast in place, or may be wet set provided concrete is properly consolidated around the embedded portion of the device. Wood members may only be attached after final set of concrete. Concrete must be fully cured prior to application of load.

Wood posts must be square cut on the bottom and concentrically fitted into the base. Notching of the posts, using undersized posts or making field alterations to the column bases are not allowed.

4.2.1 The installation of nails and bolts must be in accordance with the requirements of the NDS. Holes for bolts must be predrilled between $1/32$ -inch to $1/16$ -inch larger than the bolt diameter per 2018 and 2015 NDS Section 12.1.3.2 for the 2021, 2018, and 2015 IBC and IRC, as applicable (Section 11.1.3.2 of the 2012 NDS for the 2012 IBC and IRC).

4.3 Special Inspection:

4.3.1 IBC: For the purpose of determining special inspection requirements, connectors may be considered to be special cases in accordance with Section 1705.1.1 of the IBC (Section 1704.15 of the 2009 IBC). Periodic special inspection shall be provided except where otherwise required or accepted by specific provisions of the IBC.

4.3.2 IRC: For installations complying with the IRC, special inspection is not required.

5.0 CONDITIONS OF USE

The connectors described in this report comply with, or are suitable alternatives to what is specified in, those codes listed in Section 1.0 of this report, subject to the following conditions:

5.1 The column bases must be manufactured, identified and installed in accordance with this report and the

manufacturer's published installation instructions. A copy of the instructions must be available at the jobsite at all times during installation. In the event of conflict between this report and the manufacturer's published installation instructions, the more restrictive requirements govern.

5.2 Calculations and details showing compliance with this report must be submitted to the code official. The calculations must be prepared by a registered design professional where required by the statutes of the jurisdiction in which the project is to be constructed. Calculations and details verifying the wood post and concrete foundation's ability to resist the imposed loads must also be submitted to the code official.

5.3 Use of fasteners with preservative- or fire-retardant-treated lumber shall be in accordance with Section 3.2.3 of this report. Connectors with a G185 coating may be used with preservative- or fire-retardant-treated lumber in accordance with IBC Section 2304.10.6.1 (Section 2304.10.5.1 for the 2018 and 2015 IBC and Section 2304.9.5.1 for the 2012 IBC). Other connectors addressed in this report may be used in treated lumber in accordance with the manufacturer's recommendations only.

5.4 Embedded column bases in concrete may be installed in cracked or uncracked concrete. Cracking occurs in regions of concrete where analysis indicates cracking may occur ($f_t > f_r$), subject to the conditions of this report.

5.5 Special inspection must be provided in accordance with Section 4.3 of this report.

5.6 The embedded column bases in this report are limited in use to resisting uplift, download, and lateral loads resulting from wind loads or earthquake effects, and gravity loads only.

5.7 Minimum concrete protection for the embedded portions of the steel column bases must be as required for steel reinforcement in accordance with IBC Section 1808.8.2.

5.8 Column bases are manufactured under a quality-control program with inspections by ICC-ES.

6.0 EVIDENCE SUBMITTED

Data in accordance with the ICC-ES Acceptance Criteria for Steel Connectors for Connecting Light-Frame Construction Members to Concrete (AC398), dated February 2020 (editorially revised December 2020).

7.0 IDENTIFICATION

7.1 The connectors described in this report are identified with a die-stamped label indicating the name of the manufacturer (MiTek), the stock number, the number of the ICC-ES index evaluation report for MiTek (ESR-2685), and by one or more of the following designations: MiTek, USP Structural Connectors, or USP.

7.2 The report holder's contact information is the following:

MITEK® INC.
16023 SWINGLEY RIDGE ROAD
CHESTERFIELD, MISSOURI 63017
(800) 328-5934
www.mitek-us.com
uspcustomerservice@mii.com

TABLE 1—WAS WET POST ANCHOR ALLOWABLE LOADS^{1,2}

STOCK NUMBER	STEEL GAGE		DIMENSIONS (inches)					WOOD POST NOMINAL SIZE	FASTENER SCHEDULE ^{3,4}		ALLOWABLE LOADS (lbf) ^{5,6,7}							
											Concrete Condition	Wind and SDC A & B ⁸			SDC C through F ⁹			Download ¹⁰ C _D = 1.0
	Support Stand	Strap	W ₁	W ₂	H ₁	H ₂	L	Qty	Type	Uplift (C _D = 1.6)		F ₁ (C _D = 1.6)	F ₂ (C _D = 1.6)	Uplift (C _D = 1.6)	F ₁ (C _D = 1.6)	F ₂ (C _D = 1.6)		
WAS44	16	14	3 ⁹ / ₁₆	3 ¹ / ₂	6 ³ / ₄	3 ¹ / ₂	2 ¹ / ₄	4x4	14	16dC Nails	Uncracked	3090	1365	1095	2705	1195	960	6775
											Cracked	2165	955	770	1895	835	675	
									2	1/2"Ø Bolts	Uncracked	3075	1365	1095	2705	1195	960	6775
											Cracked	2165	955	770	1895	835	675	
WAS46	12	14	3 ⁹ / ₁₆	5 ¹ / ₂	6 ³ / ₄	3 ¹ / ₂	2 ¹ / ₄	4x6	14	16dC Nails	Uncracked	3090	1365	1095	2705	1195	960	13815
											Cracked	2165	955	770	1895	835	675	
									2	1/2"Ø Bolts	Uncracked	3075	1365	1095	2705	1195	960	13815
											Cracked	2165	955	770	1895	835	675	
WAS66	12	12	5 ¹ / ₂	5 ¹ / ₂	6 ³ / ₄	5	2 ¹ / ₄	6x6	14	16dC Nails	Uncracked	3365	1955	1685	3135	1715	1685	16005
											Cracked	2505	1370	1685	2195	1200	1665	
									2	1/2"Ø Bolts	Uncracked	3575	1955	1685	3135	1715	1685	16005
											Cracked	2505	1370	1685	2195	1200	1665	

For SI: 1 inch = 25.4 mm, 1 lbf = 4.45 N, 1 psi = 6.89 kPa

¹Design values in this table apply to the connection of the wood member to the concrete. The capacities of the wood members and concrete members are outside the scope of this report and must be determined by others.

²Refer to Figure 1 for illustrations of the WAS Wet Post Anchor and typical installation; additional installation requirements, and depiction of load directions (Uplift, F1, F2, Download).

³Allowable loads are based on fastening of the WAS anchor to the post using either nails only or bolts only. Nails and bolts must not be used in combination.

⁴A 16dC nail denotes a 16d common nail, which has a diameter of 0.162 inch and a length of 3¹/₂ inches. Bolts must meet or exceed the requirements of ASTM A307.

⁵Allowable loads are applicable to use with sawn lumber with a minimum specific gravity of 0.50.

⁶Minimum specified concrete compressive strength, f_c, is 2,500 psi.

⁷Allowable Uplift, F1 and F2 loads are based on allowable stress design (ASD) and include the load duration factor (C_D) corresponding with wind and earthquake loading in accordance with the NDS (C_D = 1.6). No further increase is allowed.

⁸To obtain design strengths for use in LRFD for Wind and SDC A & B: multiply the tabulated allowable (ASD) loads for Wind and SDC A & B by 1.67.

⁹To obtain design strengths for use in LRFD for SDC C through F: multiply the tabulated allowable (ASD) loads for SDC C thru F by 1.43.

¹⁰Allowable download capacity is applicable to lumber with a minimum compression parallel to grain reference design value of 775 psi and normal load duration. No increase is allowed for wood members with greater compression parallel to grain reference design values, or for other load durations.



FIGURE 1—WAS WET POST ANCHOR DIMENSIONS AND INSTALLATION DETAILS

TABLE 2—WE WET POST ANCHOR ALLOWABLE LOADS^{1,2}

STOCK NUMBER	STEEL GAGE	DIMENSIONS (inches)				WOOD POST NOMINAL SIZE ³	FASTENER SCHEDULE ^{4,5}		Concrete Condition	ALLOWABLE LOADS (lbf) ^{6,7}						
										Wind and SDC A & B ^{8,9}			SDC C through F ^{8,10}			DOWN-LOAD ¹¹ (C _D = 1.0)
		W ₁	H ₁	H ₂	L		Qty	Type		Uplift (C _D = 1.6)	F1 (C _D = 1.6)	F2 (C _D = 1.6)	Uplift (C _D = 1.6)	F1 (C _D = 1.6)	F2 (C _D = 1.6)	
WE44	12	3 1/2	4 3/4	3 3/8	3 1/4	4x4	12	16dC	Uncracked	1405	860	970	1255	755	850	15335
									Cracked	1245	600	680	1090	525	595	
								1/2" Ø Bolts	Uncracked	1430	860	970	1255	755	850	
									Cracked	1245	600	680	1090	525	595	
WE44R	12	4	5	3 5/8	3 3/8	4X4 Rough	12	16dC	Uncracked	1405	860	970	1255	755	850	
									Cracked	1245	600	680	1090	525	595	
WE46	12	5 1/2	4 3/4	3 3/8	3 1/4	4x6	12	16dC	Uncracked	1405	860	970	1255	755	850	24130
									Cracked	1245	600	680	1090	525	595	
								1/2" Ø Bolts	Uncracked	1430	860	970	1255	755	850	
									Cracked	1245	600	680	1090	525	595	
WE46R	12	6	5	3 5/8	3 3/8	4x6 Rough	12	16dC	Uncracked	1405	860	970	1255	755	850	
									Cracked	1245	600	680	1090	525	595	
WE66	12	5 1/2	5	3 3/8	5 3/8	6x6	12	16dC	Uncracked	1405	860	970	1255	755	850	29565
									Cracked	1245	600	680	1090	525	595	
WE66R	12	6	5	3 5/8	5 3/8	6x6 Rough	12	16dC	Uncracked	1405	860	970	1255	755	850	
									Cracked	1245	600	680	1090	525	595	

For SI: 1 inch = 25.4 mm, 1 lbf = 4.45 N, 1 psi = 6.89 kPa

¹Design values in this table apply to the connection of the wood member to the concrete. The capacities of the wood members and concrete members are outside the scope of this report and must be determined by others.

²Refer to Figure 2 for illustrations of the WE Wet Post Anchor and typical installation; additional installation requirements, and depiction of load directions (Uplift, F1, F2).

³Actual dimensions of rough-sized lumber must be in accordance with Standard Grading Rules for West Coast Lumber No. 17, West Coast Lumber Inspection Bureau.

⁴Allowable loads are based on fastening of the WE anchor to the post using either nails only or bolts only. Nails and bolts must not be used in combination.

⁵A 16dC nail denotes a 16d common nail, which has a diameter of 0.162 inch and a length of 3 1/2 inches. Bolts must meet or exceed the requirements of ASTM A307.

⁶Allowable loads are applicable to use with sawn lumber with a minimum specific gravity of 0.50.

⁷Minimum specified concrete compressive strength, f'_c, is 2,500 psi.

⁸Allowable Uplift, F1 and F2 loads are based on allowable stress design (ASD) and include the load duration factor (C_D) corresponding with wind and seismic loading in accordance with the NDS (C_D = 1.6). No further increase is allowed.

⁹To obtain design strengths for use in LRFD for Wind and SDC A & B: multiply the tabulated allowable (ASD) loads for Wind and SDC A & B by 1.67.

¹⁰To obtain design strengths for use in LRFD for SDC C thru F: multiply the tabulated allowable (ASD) loads for SDC C through F by 1.43.

¹¹Download capacity is based upon a parallel-to-grain bearing capacity of 1350 psi for posts less than nominal 5-by-5 and 1000 psi for posts 5-by-5 nominal and larger.

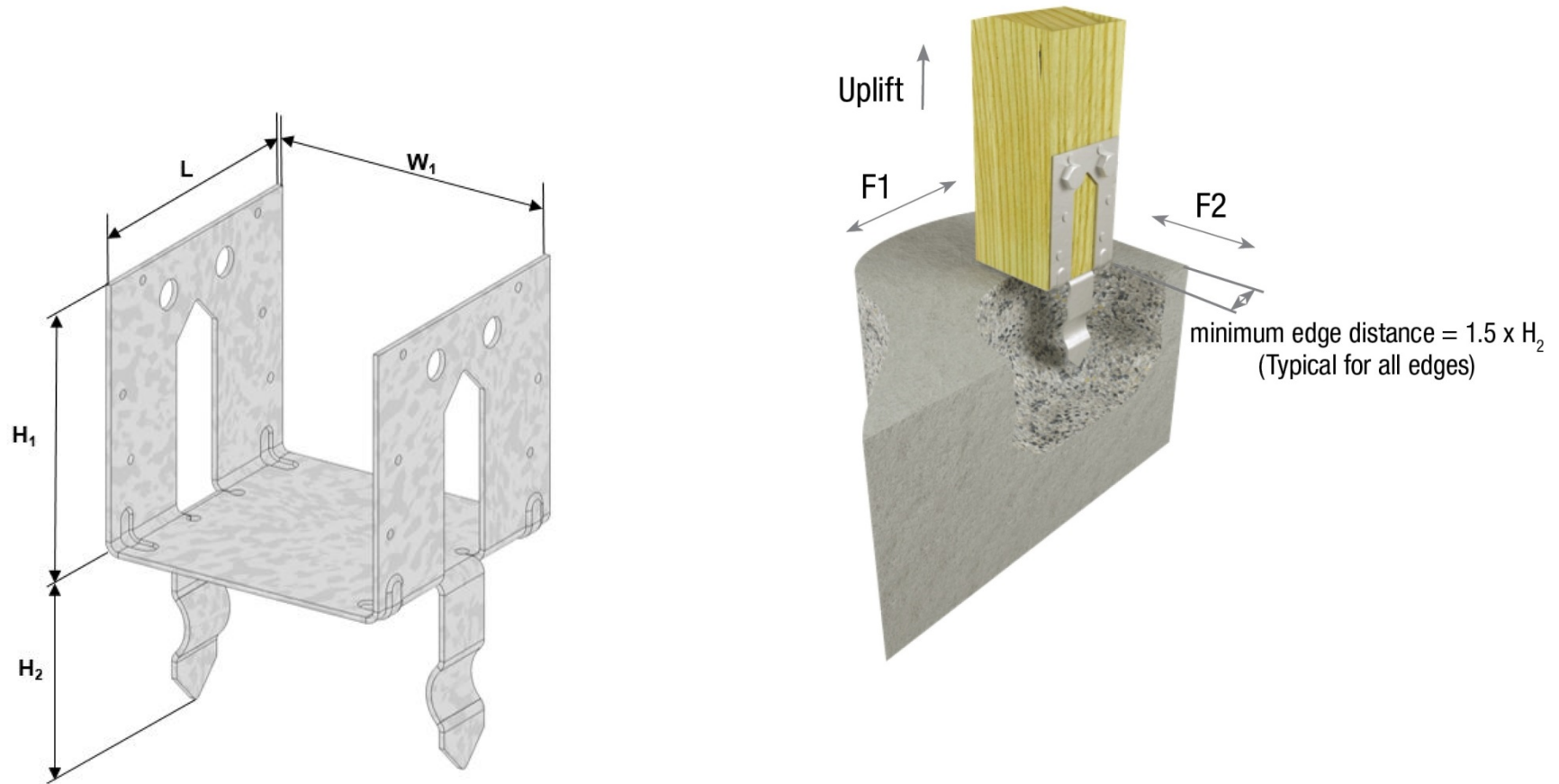

FIGURE 2—WE WET POST ANCHOR DIMENSIONS AND INSTALLATION DETAILS

TABLE 3—EPB/EBG ELEVATED POST BASE ALLOWABLE LOADS^{1,2}

STOCK NUMBER	BUCKET STEEL GAGE	STEM	DIMENSIONS (inches)				WOOD POST NOMINAL SIZE	FASTENER SCHEDULE ³		Concrete Condition	ALLOWABLE LOADS (lbf) ^{4,5,6,7}						
											Wind and SDC A and B ⁸			SDC C through F ⁹			Down-load ¹⁰ (C _D = 1.0)
			W	L	H ₁	H ₂		Qty	Type		Uplift (C _D = 1.6)	F1 (C _D = 1.6)	F2 (C _D = 1.6)	Uplift (C _D = 1.6)	F1 (C _D = 1.6)	F2 (C _D = 1.6)	
EPB4408	12	Tube	3 ⁹ / ₁₆	3	3	8	4x4	8	16dC	Uncracked	1110	1440	1295	970	1260	1135	3045
										Cracked	775	1010	905	680	885	795	
EPB4608	12	Tube	3 ⁹ / ₁₆	5	3	8	4x6	12	16dC	Uncracked	1110	1440	1295	970	1260	1135	3045
										Cracked	775	1010	905	680	885	795	
EPB6608	12	Tube	5 ⁹ / ₁₆	5	3 ³ / ₁₆	8	6x6	12	16dC	Uncracked	1110	1440	1295	970	1260	1135	4665
										Cracked	775	1010	905	680	885	795	
EBG44-TZ	14	Tube	3 ⁹ / ₁₆	2 ³ / ₄	2 ³ / ₈	7 ¹ / ₂	4x4	8	16dC	Uncracked	1085	1440	1295	1000	1260	1135	4615
										Cracked	800	1010	905	700	885	795	

For SI: 1 inch = 25.4 mm, 1 lbf = 4.45 N, 1 psi = 6.89 kPa

¹Design values in this table apply to the connection of the wood member to the concrete. The capacities of the wood members and concrete members are outside the scope of this report and must be determined by others.

²Refer to Figure 3 for illustrations of the Elevated Post Bases and typical installation; additional installation requirements; and depiction of load directions (Uplift, F1, F2, Download).

³A 16dC nail denotes a 16d common nail, which has a diameter of 0.162 inch and a length of 3¹/₂ inches.

⁴Allowable loads are applicable to use with sawn lumber with a minimum specific gravity of 0.50.

⁵Allowable loads are based on a maximum distance of 1 inch between the top of the concrete foundation and the bottom of the steel bucket.

⁶Minimum specified concrete compressive strength, *f_c*, is 2,500 psi.

⁷Allowable Uplift, F1, and F2 loads are based on allowable stress design (ASD) and include the load duration factor (C_D) corresponding to wind and earthquake loading in accordance with the NDS (C_D = 1.6). No further increase is allowed.

⁸To obtain design strengths for use in LRFD for Wind and SDC A & B: multiply the tabulated allowable (ASD) loads for Wind and SDC A and B by 1.67.

⁹To obtain design strengths for use in LRFD for SDC C through F: multiply the tabulated allowable (ASD) loads for SDC C through F by 1.43.

¹⁰Allowable download capacity is applicable to lumber with a minimum compression parallel to grain reference design value of 775 psi and normal load duration. No increase is allowed for wood members with greater compression parallel to grain reference design values, or for other load durations.

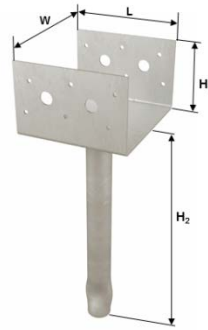

EPB

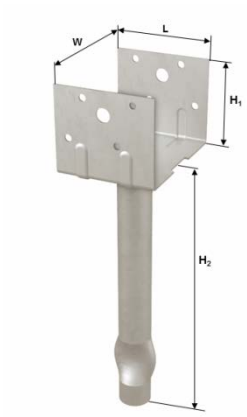

EBG44-TZ

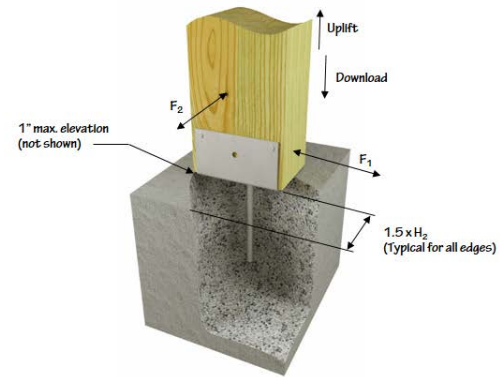

EBG44-TZ Installation (EPB and EPBH Similar)

FIGURE 3—EPB / EBG ELEVATED POST BASE DIMENSIONS AND INSTALLATION DETAILS

TABLE 4—CBE COLUMN BASE SERIES ALLOWABLE LOADS ^{1,2,12}

STOCK NO.	STEEL GAGE		DIMENSIONS (inches)					WOOD POST NOMINAL SIZE ³	FASTENER SCHEDULE ^{4,5}		ALLOWABLE UPLIFT LOADS (lbs.) ^{6,7,8,10,11}				DOWNLOAD ¹² (C _D =1.0)
	Strap	Base	W1	W2	H	L	Embedment ⁹		Qty	Type	Uncracked Concrete		Cracked Concrete		
											Wind and SDC A,B (C _D =1.60)	SDC C through F (C _D =1.60)	Wind and SDC A,B (C _D =1.60)	SDC C through F (C _D =1.60)	
CBE44	12	12	3 ⁹ / ₁₆	3 ¹ / ₂	7 ¹ / ₂	2	6 ¹ / ₂	4x4	12	16dC	2975	2975	2975	2770	
									2	1/2 Ø Bolt	4090	3605	3160	2770	
CBE44R	12	12	4 ¹ / ₁₆	3 ¹ / ₂	7 ¹ / ₂	2	6 ¹ / ₄	4x4 Rough	12	16dC	2975	2975	2975	2770	
									2	1/2 Ø Bolt	4090	3605	3160	2770	
CBE46	12	12	3 ⁹ / ₁₆	5 ¹ / ₂	7 ¹ / ₂	2	6 ¹ / ₂	4x6	12	16dC	2975	2975	2975	2770	
									2	1/2 Ø Bolt	4090	3605	3160	2770	
CBE46R	12	12	4 ¹ / ₁₆	5 ¹ / ₂	7 ¹ / ₂	2	6 ¹ / ₄	4x6 Rough	12	16dC	2975	2975	2975	2770	
									2	1/2 Ø Bolt	4090	3605	3160	2770	
CBE66	12	12	5 ¹ / ₂	5 ¹ / ₂	7 ¹ / ₂	2	5 ¹ / ₂	6x6	12	16dC	2975	2975	2975	2770	
									2	1/2 Ø Bolt	4090	3605	3160	2770	
CBE66R	12	12	6 ¹ / ₁₆	6	7 ¹ / ₂	2	5 ¹ / ₄	6x6 Rough	12	16dC	2975	2975	2975	2770	
									2	1/2 Ø Bolt	4090	3605	3160	2770	

For **SI**: 1 inch = 25.4 mm, 1 lbf = 4.45 N, 1 psi = 6.89 kPa

¹Design values in this table apply to the connection of the wood member to the concrete. The capacities of the wood members and concrete members are outside the scope of this report and must be determined by others.

²Refer to Figure 4 for illustrations of the CBE Column Base and typical installation in a concrete slab, additional installation requirements, and load direction (uplift). See Section 3.1.4 for installation in a cast-in-place concrete pier.

³Actual dimensions of rough-sized lumber must be in accordance with Standard Grading Rules for West Coast Lumber No. 17, West Coast Lumber Inspection Bureau.

⁴ Allowable loads are based on fastening of the CBE anchor to the post using either nails only or bolts only. Nails and bolts must not be used in combination.

⁵A 16dC nail denotes a 16d common nail, which has a diameter of 0.162 inch and a length of 3¹/₂ inches. Bolts must meet or exceed the requirements of ASTM A307.

⁶Allowable loads are applicable to use with sawn lumber with a minimum specific gravity of 0.50.

⁷Minimum specified concrete compressive strength, *f_c*, is 2,500 psi. ⁸Allowable Uplift loads are based on allowable stress design (ASD) and include the load duration factor (C_D) corresponding with wind or seismic loading in accordance with the NDS (C_D = 1.6). No further increase is allowed.

⁹The CBE device shall be embedded into concrete up to this depth.

¹⁰To obtain design strengths for use in LRFD for Wind and SDC A & B: multiply the tabulated allowable (ASD) loads for Wind and SDC A & B by 1.67.

¹¹To obtain design strengths for use in LRFD for SDC C through F: multiply the tabulated allowable (ASD) loads for SDC C through F by 1.43.

¹²Download capacity is based upon a parallel-to-grain bearing capacity of 1350 psi for posts less than nominal 5-by-5 and 1000 psi for posts 5-by-5 (nominal) and larger.

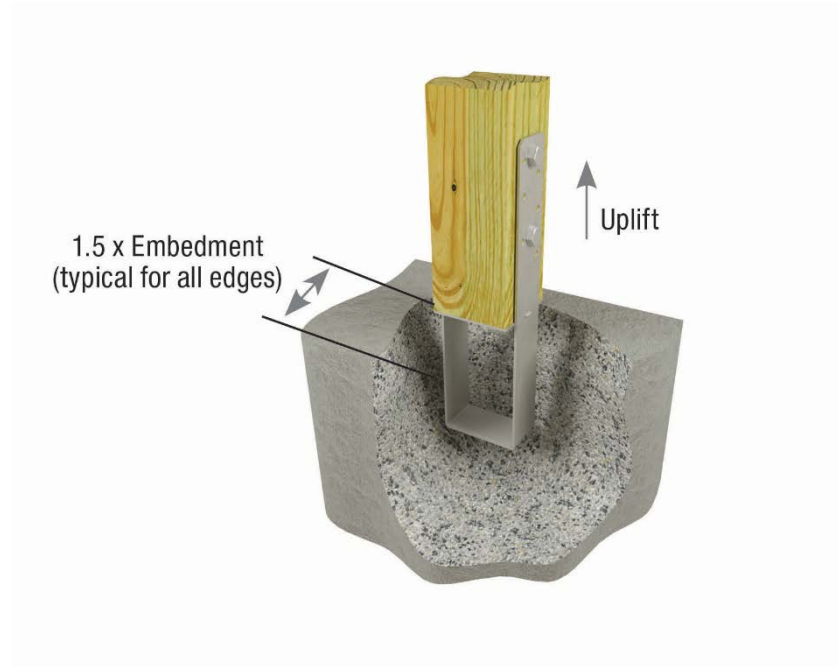
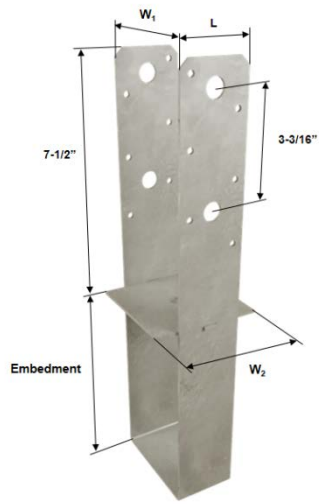

FIGURE 4—CBE COLUMN BASE DIMENSIONS AND INSTALLATION DETAILS (BOLTS OPTION SHOWN)

TABLE 5—EPBT-TZ ELEVATED POST BASE ALLOWABLE LOADS^{1,2}

STOCK NUMBER	STEEL GAGE	THREAD ROD DIA. (inch)	DIMENSIONS (inches)				WOOD POST SIZE	FASTENER SCHEDULE ³		INSTALLATION TYPE	ALLOWABLE LOADS (lbf) ^{4,5,6}	
											Uncracked Concrete Wind and SDC A and B Uplift ^{7,8,10} (C _D = 1.60)	Download ⁹ C _D = 1.0
	Bucket		W	L	H1	H2		Qty	Type			
EPB44T-TZ	12	5/8	3 ⁹ / ₁₆	2 ⁷ / ₈	2 ⁷ / ₁₆	4 ⁷ / ₈	4x4	8	10dC	Concrete Pier Block ¹¹	- -	5525
										Cast-in-place Concrete	790	5525

For SI: 1 inch = 25.4 mm, 1 lbf = 4.45 N, 1 psi = 6.89 kPa

¹Design values in this table apply to the connection of the wood member to the concrete. The capacities of the wood members and concrete members are outside the scope of this report and must be determined by others.

²Refer to Figure 5 for illustrations of the EPBT Post Base and typical installation; additional installation requirements, and load direction (uplift and download).

³A 10dC nail has a diameter of 0.148 inch and a length of 3 inches.

⁴Allowable loads are applicable to use with sawn lumber with a specific gravity of 0.50.

⁵Allowable loads are based on a maximum distance of 2¹/₂ inches between the concrete foundation and the bottom of the post base.

⁶Minimum specified concrete compressive strength, *f*_c, is 2,500 psi.

⁷Allowable Uplift loads are based on allowable stress design (ASD) and include the load duration factor (C_D) corresponding with wind and earthquake loading in accordance with the NDS (C_D = 1.6). No further increase is allowed.

⁸To obtain design strengths for use in LFRD for Wind and SDC A & B: multiply the tabulated allowable (ASD) loads for Wind and SDC A and B by 1.67.

⁹The Allowable download capacity is applicable to lumber with a minimum compression parallel to grain reference design value of 775 psi and normal load duration. No increase is allowed for wood members with greater compression parallel to grain reference design values, or for other load durations.

¹⁰The Allowable Uplift capacity requires a minimum edge distance of 5 inches and concrete member capable of resisting the upward force. The Allowable Download capacity requires a minimum edge distance of 4 inches.

¹¹For Pier Block installation, drill a 5/8-inch-diameter hole a minimum of 4 inches deep.

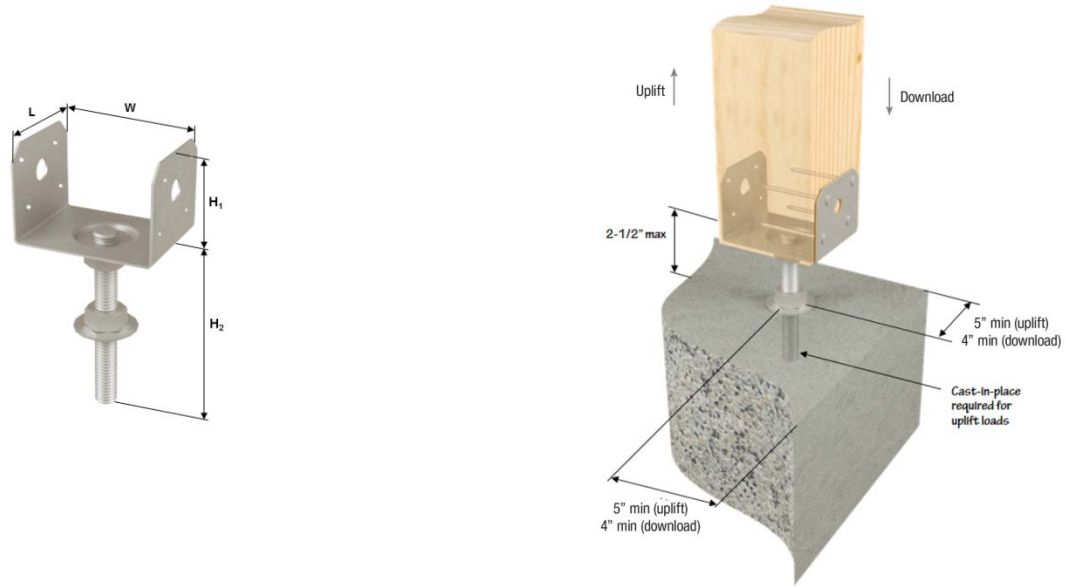

FIGURE 5—EPB44T-TZ ELEVATED POST BASE DIMENSIONS AND INSTALLATION DETAILS

DIVISION: 03 00 00—CONCRETE
Section: 03 16 00—Concrete Anchors

DIVISION: 06 00 00—WOOD, PLASTICS, AND COMPOSITES
Section: 06 05 23—Wood, Plastic, and Composite Fastenings

REPORT HOLDER:

MITEK® INC.

EVALUATION SUBJECT:

MITEK COLUMN BASES EMBEDDED IN CONCRETE

1.0 REPORT PURPOSE AND SCOPE

Purpose:

The purpose of this evaluation report supplement is to indicate that the MiTek Column Bases Embedded in Concrete, described in ICC-ES evaluation report [ESR-3754](#), have also been evaluated for compliance with the codes noted below as adopted by the Los Angeles Department of Building and Safety (LADBS).

Applicable code editions:

- 2020 *City of Los Angeles Building Code* (LABC)
- 2020 *City of Los Angeles Residential Code* (LARC)

2.0 CONCLUSIONS

The MiTek Column Bases Embedded in Concrete, described in Sections 2.0 through 7.0 of the evaluation report [ESR-3754](#), comply with the LABC Chapters 19, 22 and 23, and the LARC, and are subjected to the conditions of use described in this supplement.

3.0 CONDITIONS OF USE

The MiTek Column Bases Embedded in Concrete described in this evaluation report supplement must comply with all of the following conditions:

- All applicable sections in the evaluation report [ESR-3754](#).
- The design, installation, conditions of use and identification of the MiTek Column Bases Embedded in Concrete are in accordance with the 2018 *International Building Code*® (IBC) provisions noted in the evaluation report [ESR-3754](#).
- The design, installation and inspection are in accordance with additional requirements of LABC Chapters 16 and 17, as applicable.
- Under the LARC, an engineered design in accordance with LARC Section R301.1.3 must be submitted.
- The seismic design provisions for hillside buildings referenced in LABC Section 2301.1 have not been considered and are outside the scope of this supplement.

This supplement expires concurrently with the evaluation report, reissued September 2021.

DIVISION: 03 00 00—CONCRETE

Section: 03 16 00—Concrete Anchors

DIVISION: 06 00 00—WOOD, PLASTICS, AND COMPOSITES

Section: 06 05 23—Wood, Plastic, and Composite Fastenings

REPORT HOLDER:

MITEK® INC.

EVALUATION SUBJECT:

MITEK COLUMN BASES EMBEDDED IN CONCRETE

1.0 REPORT PURPOSE AND SCOPE

Purpose:

The purpose of this evaluation report supplement is to indicate that MiTek Column Bases Embedded in Concrete, described in ICC-ES evaluation report ESR-3754, have also been evaluated for compliance with the codes noted below.

Applicable code editions:

- 2020 *Florida Building Code—Building*
- 2020 *Florida Building Code—Residential*

2.0 CONCLUSIONS

The MiTek Column Bases Embedded in Concrete, described in Sections 2.0 through 7.0 of ICC-ES evaluation report ESR-3754, complies with the *Florida Building Code—Building* and the *Florida Building Code—Residential*, provided the design requirements are determined in accordance with the *Florida Building Code—Building* or the *Florida Building Code—Residential*, as applicable. The installation requirements noted in ICC-ES evaluation report ESR-3754 for the 2018 *International Building Code*® meet the requirements of the *Florida Building Code—Building* or the *Florida Building Code—Residential*, as applicable.

Use of the MiTek Column Bases Embedded in Concrete has also been found to be in compliance with the High-Velocity Hurricane Zone provisions of the *Florida Building Code—Building* and the *Florida Building Code—Residential* with the following condition:

- a) For connections subject to uplift, the connection must be designed for no less than 700 pounds (3114 N).

For products falling under Florida Rule 61G20-3, verification that the report holder's quality assurance program is audited by a quality assurance entity approved by the Florida Building Commission for the type of inspections being conducted is the responsibility of an approved validation entity (or the code official when the report holder does not possess an approval by the Commission).

This supplement expires concurrently with ICC-ES evaluation report ESR-3754, reissued September 2021.