

DIVISION: 06 00 00—WOOD, PLASTICS AND COMPOSITES
Section: 06 05 23—Wood, Plastic, and Composite Fastenings

REPORT HOLDER:

MITEK INC.

EVALUATION SUBJECT:

MITEK® STABILIZER™

1.0 EVALUATION SCOPE

Compliance with the following codes:

- 2021, 2018, 2015, 2012, 2009, and 2006 *International Building Code*® (IBC)
- 2021, 2018, 2015, 2012, 2009, and 2006 *International Residential Code*® (IRC)

For evaluation for compliance with codes adopted by Los Angeles Department of Building and Safety (LADBS), see [ESR-2362 LABC and LARC Supplement](#).

Property evaluated:

Structural

2.0 USES

The MiTek® Stabilizer™ is used as temporary or permanent lateral bracing for nominally 2-inch-wide wood truss members spaced 24 inches (610 mm) on center.

3.0 DESCRIPTION

The MiTek® Stabilizer™ is an upside-down U-shaped member formed using steel with a base-metal thickness of 0.036 inch (0.91 mm) that conforms to ASTM A653 SS Grade 40. The steel has a G60 galvanized coating complying with ASTM A653. Each side flange of the U-shaped connector is 1 inch (25 mm) wide, and the center web is 1½ inches (38 mm) wide. Each end of the connector has two flange tabs that are formed at approximately 71 degrees to the side flanges. These flange tabs create the location points used to establish truss spacing. Each flange tab has a set of integral teeth that are stamped and formed at right angles to the parent metal. Each set of integral teeth is fabricated by punching two teeth into the flange tab with each tooth forming a slot 0.45-inch long (11 mm) and 0.125-inch wide (3 mm). When the flange tabs are formed, the remaining steel produces a web tab that laps over the member being braced. Four series of teeth are stamped and formed at right angles to the parent metal into the web tab. The teeth are identical to the teeth formed into the flange

tabs. The longitudinal centerlines of the adjacent slots are staggered 0.25 inch (6 mm) in the transverse direction. The transverse centerlines of the slots are staggered 0.15 inch (4 mm) in the longitudinal direction. Each slot has a 0.33-inch-long (8 mm) tooth at each end. Each tooth is additionally shaped into an approximate 22-degree twist at its end. This process of forming flange tabs, web tabs and integral teeth is applied at both ends of the Stabilizer™. See Figure 1.

4.0 DESIGN AND INSTALLATION

4.1 Design:

The maximum allowable axial load capacity of the MiTek® Stabilizer™ is as shown in Table 1. The wood framing, having nominally 2-inch-wide (51 mm) members to which the Stabilizer™ is attached, must have a minimum specific gravity of 0.42. Lateral bracing design, details and locations must comply with the requirements of IBC Section 2303.4 or IRC Section R802.10.3.

4.2 Installation:

The MiTek® Stabilizer™ is installed at right angles in the plane of the nominally 2-inch-wide wood truss members by driving the teeth on the web tab of the Stabilizer™ down into the narrow edge of the wood truss member using a hammer. The flange tabs must then be secured by driving the teeth of each flange tab into the face of the truss member. The Stabilizer™ is properly installed when the web tab and flange tabs are flush with the truss member, with the teeth fully embedded into the truss member. The allowable axial load in tension may be increased to the value specified in Table 1 when one 8d or 10d common wire nail is installed through one of the tooth slots of each web tab into the truss member, as illustrated in Figure 2. The Stabilizer™ must be staggered in adjacent truss bays with the web tabs in side-to-side contact.

5.0 CONDITIONS OF USE

The MiTek® Stabilizer™ described in this report complies with, or is a suitable alternative to what is specified in, those codes listed in Section 1.0 of this report, subject to the following conditions:

- 5.1** The Stabilizer™ is located where there are no wood defects, such as knots.
- 5.2** The Stabilizer™ is limited to use with untreated lumber and dry service conditions.
- 5.3** The Stabilizer™ locations must be on the truss design drawings in accordance with Section 2303.4 of the IBC.
- 5.4** The MiTek® Stabilizer™ is manufactured by MiTek, Inc. in Hazelwood, Missouri, under a quality-control program with inspections by ICC-ES.

6.0 EVIDENCE SUBMITTED

- 6.1 Test reports on compression, tension and moment capacity.
- 6.2 A quality-control manual.

7.0 IDENTIFICATION

- 7.1 The MiTek® Stabilizer™ itself or the packaging must be labeled with the manufacturer's name (MiTek, Inc.), manufacturing location, the product name (Stabilizer™) and the evaluation report number (ESR-2362).

7.2 The report holder's contact information is the following:

MITEK INC.
16023 SWINGLEY RIDGE ROAD
CHESTERFIELD, MISSOURI 63017
(800) 328-5934
www.mitek-us.com

TABLE 1—ALLOWABLE AXIAL LOAD

TYPE OF LOAD	CAPACITY ^{1,2} (lbs)
Tension	105
Tension (with fastener ²)	155
Compression	420

For SI: 1 pound = 4.448 N.

¹Wood framing must have a minimum specific gravity of 0.42.

²Fastener must be one 8d or 10d common wire nail installed through one of the slots in the web tab. (See Figure 2.)

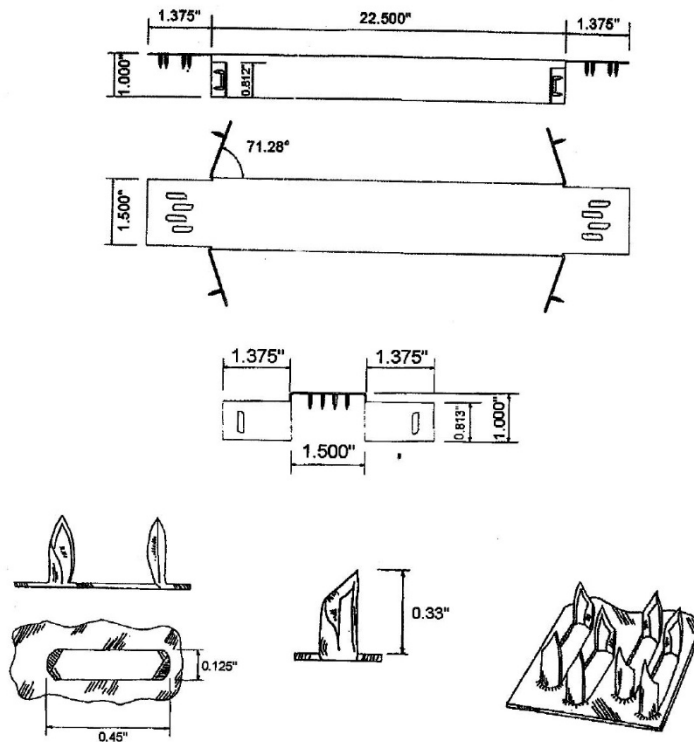

FIGURE 1—STABILIZER™

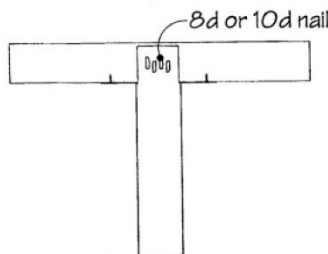

FIGURE 2—FASTENER INSTALLATION

DIVISION: 06 00 00—WOOD, PLASTICS, AND COMPOSITES
Section: 06 05 23—Wood, Plastic, and Composite Fastenings

REPORT HOLDER:

MITEK INC.

EVALUATION SUBJECT:

MITEK® STABILIZER™

1.0 REPORT PURPOSE AND SCOPE**Purpose:**

The purpose of this evaluation report supplement is to indicate that the Mitek® Stabilizer™, described in ICC-ES evaluation report [ESR-2362](#), have also been evaluated for compliance with the codes noted below as adopted by the Los Angeles Department of Building and Safety (LADBS).

Applicable code editions:

- 2020 *City of Los Angeles Building Code* (LABC)
- 2020 *City of Los Angeles Residential Code* (LARC)

2.0 CONCLUSIONS

The Mitek® Stabilizer™, described in Sections 2.0 through 7.0 of the evaluation report [ESR-2362](#), comply with the LABC Chapter 23, and the LARC, and are subjected to the conditions of use described in this supplement.

3.0 CONDITIONS OF USE

The Mitek® Stabilizer™ described in this evaluation report must comply with all of the following conditions:

- All applicable sections in the evaluation report [ESR-2362](#).
- The design, installation, conditions of use and labeling are in accordance with the 2018 *International Building Code*® (2018 IBC) provisions noted in the evaluation report [ESR-2362](#).
- The design, installation and inspection are in accordance with additional requirements of LABC Chapters 16, 17 and 23, and LARC Section R802, as applicable.
- Metal connector teeth with 1/2 inch of the ends of truss wood members must be considered ineffective to carry any load.

This evaluation report supplement expires concurrently with the evaluation report ESR-2362, reissued May 2021.

DIVISION: 06 00 00—WOOD, PLASTICS AND COMPOSITES
Section: 06 05 23—Wood, Plastic, and Composite Fastenings

REPORT HOLDER:

MITEK INC.

EVALUATION SUBJECT:

MITEK® STABILIZER™

1.0 REPORT PURPOSE AND SCOPE**Purpose:**

The purpose of this evaluation report supplement is to indicate that the Mitek® Stabilizer™, described in ICC-ES evaluation report ESR-2362, has also been evaluated for compliance with the codes noted below.

Applicable code editions:

- 2019 *California Building Code (CBC)*

For evaluation of applicable chapters adopted by the California Office of Statewide Health Planning and Development (OSHPD) and Division of the State Architect (DSA), see Sections 2.1.1 and 2.1.2 below.

- 2019 *California Residential Code (CRC)*

2.0 CONCLUSIONS**2.1 CBC:**

The Mitek® Stabilizer™, described in Sections 2.0 through 7.0 of the evaluation report ESR-2362, complies with CBC Chapter 23, provided the design and installation are in accordance with the 2018 *International Building Code*® (IBC) provisions noted in the evaluation report, and the additional requirements of the CBC Chapters 16, 17, and 23, as applicable.

2.1.1 OSHPD: OSHPD requirements as indicated in the CBC are beyond the scope of this supplement.

2.1.2 DSA: DSA requirements as indicated in the CBC are beyond the scope of this supplement.

2.2 CRC

The Mitek® Stabilizer™, described in Sections 2.0 through 7.0 of the evaluation report ESR-2362, comply with the CRC Chapter 8, provided the design and installation are in accordance with the 2018 *International Residential Code*® (IRC) provisions noted in the evaluation report.

This evaluation report supplement expires concurrently with the evaluation report ESR-2362, reissued May 2021.

DIVISION: 06 00 00—WOOD, PLASTICS AND COMPOSITES
Section: 06 05 23—Wood, Plastic, and Composite Fastenings

REPORT HOLDER:

MITEK INC.

EVALUATION SUBJECT:

MITEK® STABILIZER™

1.0 REPORT PURPOSE AND SCOPE**Purpose:**

The purpose of this evaluation report supplement is to indicate that the MiTek® Stabilizer™, described in ICC-ES report ESR-2362, has also been evaluated for compliance with the codes noted below.

Applicable code editions:

- 2020 *Florida Building Code—Building*
- 2020 *Florida Building Code—Residential*

2.0 CONCLUSIONS

The MiTek® Stabilizer™, described in Sections 2.0 through 7.0 of the evaluation report ESR-2362, complies with the *Florida Building Code—Building* and the *Florida Building Code—Residential*, provided the design requirements are determined in accordance with the *Florida Building Code—Building* or the *Florida Building Code—Residential*, as applicable. The installation requirements noted in ICC-ES evaluation report ESR-2362 for the 2018 *International Building Code*® meet the requirements of the *Florida Building Code—Building* or the *Florida Building Code—Residential*, as applicable, with the following conditions:

Use of the MiTek® Stabilizer™ has also been found to be in compliance with the High-Velocity Hurricane Zone provisions of the *Florida Building Code—Building* and the *Florida Building Code—Residential*.

For products falling under Florida Rule 61G20-3, verification that the report holder's quality-assurance program is audited by a quality-assurance entity approved by the Florida Building Commission for the type of inspections being conducted is the responsibility of an approved validation entity (or the code official when the report holder does not possess an approval by the Commission).

This evaluation report supplement expires concurrently with the evaluation report ESR-2362, reissued May 2021.