

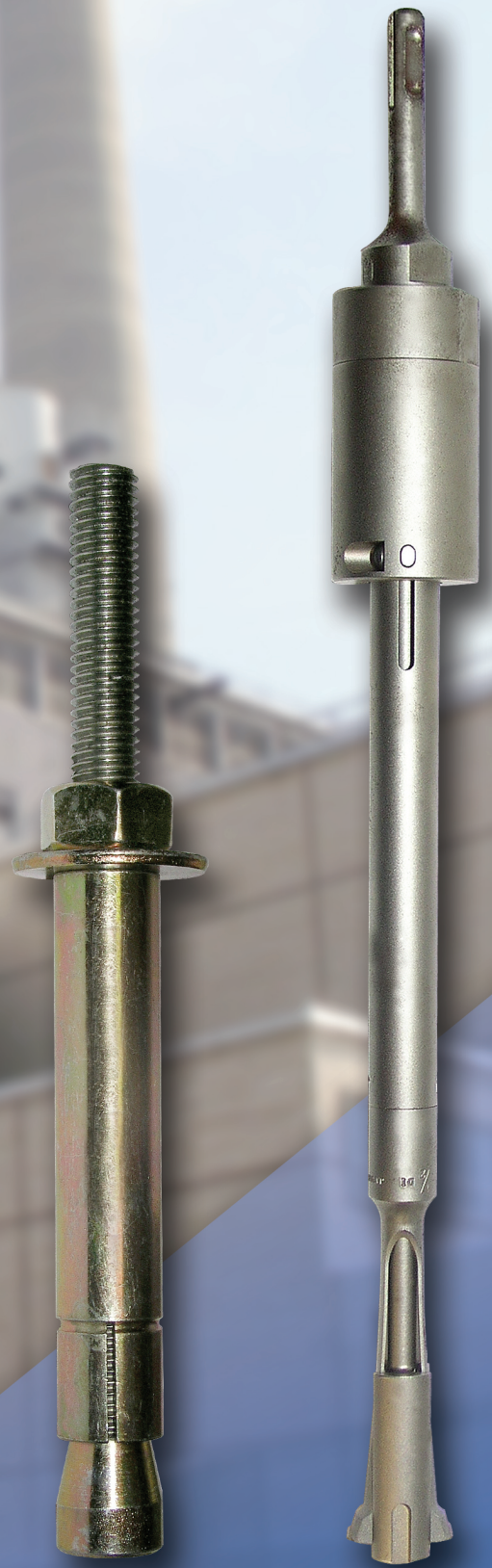

# DUCTILE UNDERCUT ANCHORS

ICC-ES ESR-1970 (2012 IBC)  
FL 17229 (2014 FBC)  
RR 25836 (2014 LABC)



MiTek<sup>®</sup>

Better Technology. Better Building.<sup>SM</sup>



## How It Works

The DUC Undercut Anchor consists of an ASTM A36 or A193 Grade B7 threaded stud, a thick-walled expansion sleeve, an expander coupling and a nut and washer (316 stainless steel is also available).

The DUC Undercut Anchor is installed into a pre-drilled hole which has been enlarged at the bottom in the shape of a reversed cone. The reverse cone is created using the USP DUC Undercutting Bit. The DUC Undercutting Bit fits into SDS or SDS Max rotary hammer drills and guarantees the correct angle of the reverse cone. The anchor is expanded into the reverse cone when the expansion sleeve is driven over the expander coupling.

The result is an anchor which transfers load mainly through bearing, and unlike a typical expansion anchor (sleeve, heavy duty sleeve, wedge and drop-ins), the DUC is not dependent upon friction between the expansion sleeve and the concrete. Due to the use of a thick walled expansion sleeve, the load is distributed to a large area which ensures ductile behavior of the anchor even at relatively shallow embedments.

**The DUC Undercut Anchors have been tested in accordance with ACI 355.2 to be qualified for use with the design methods of ACI 318 appendix D, including recognition in cracked concrete.**

## Available Anchor Sizes

38-275L*	12-500HT	58-900H
38-275LT	12-675H	58-900HT
38-400H	12-675HT	34-500L
38-400HT	58-450L	34-500LT
12-400L	58-450LT	34-1000H
12-400LT	58-750H	34-1000HT
12-500H	58-750HT	

\*38-275L = 3/8" dia. rod, 2.75" embedment

**L:** ASTM A36 steel rod, sleeve length = embedment length

**LT:** ASTM A36 steel rod, sleeve length = embedment length plus 1-3/4" for ledger attachment

**H:** ASTM A193 steel rod, sleeve length = embedment length

**HT:** ASTM A193 steel rod, sleeve length = embedment length plus 1-3/4" for ledger attachment

## DUC Undercut Anchor Advantages

Compared with heavy capacity sleeve and expansion anchors and other undercut systems:

- DUC Undercut design provides consistent expansion and is easy to set. Stress risers have been eliminated to prevent tearing.
- Large bearing area provides exceptional performance even in lower strength concrete.
- Load transfers mainly through bearing, not expansion forces and is not dependent upon friction which can be lost when cracks occur.
- Thick walled sleeves transfer load over a larger area which insures predictable ductile performance.
- ASTM A36 or A193 grade B7 rods are used. Full ultimate steel strength of the threaded stud is developed at listed embedment and spacing. Stainless steel is also available.
- Installation is simple. It is similar to installing a typical expansion anchor; no coring drills are necessary. Creation of proper undercut is correctly done and easily verified using DUC Undercut Bits. Creation of undercut takes only seconds.

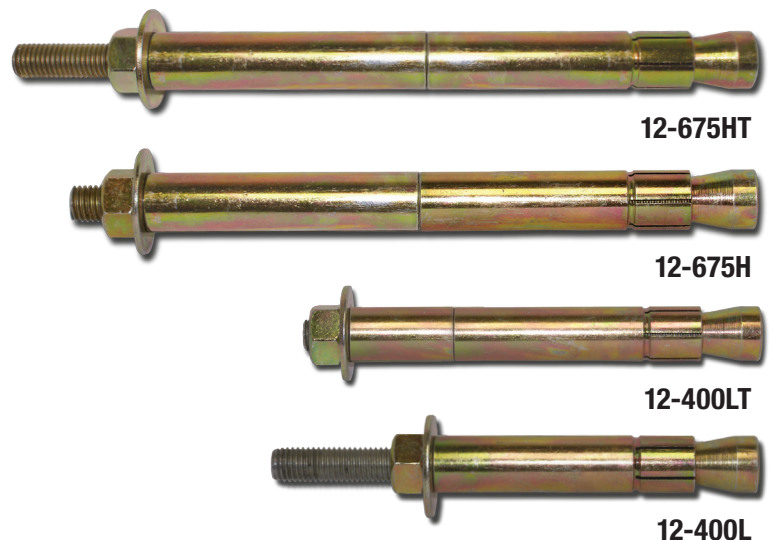



## Ductile Undercut (DUC) Undercut Anchor Installation Instructions

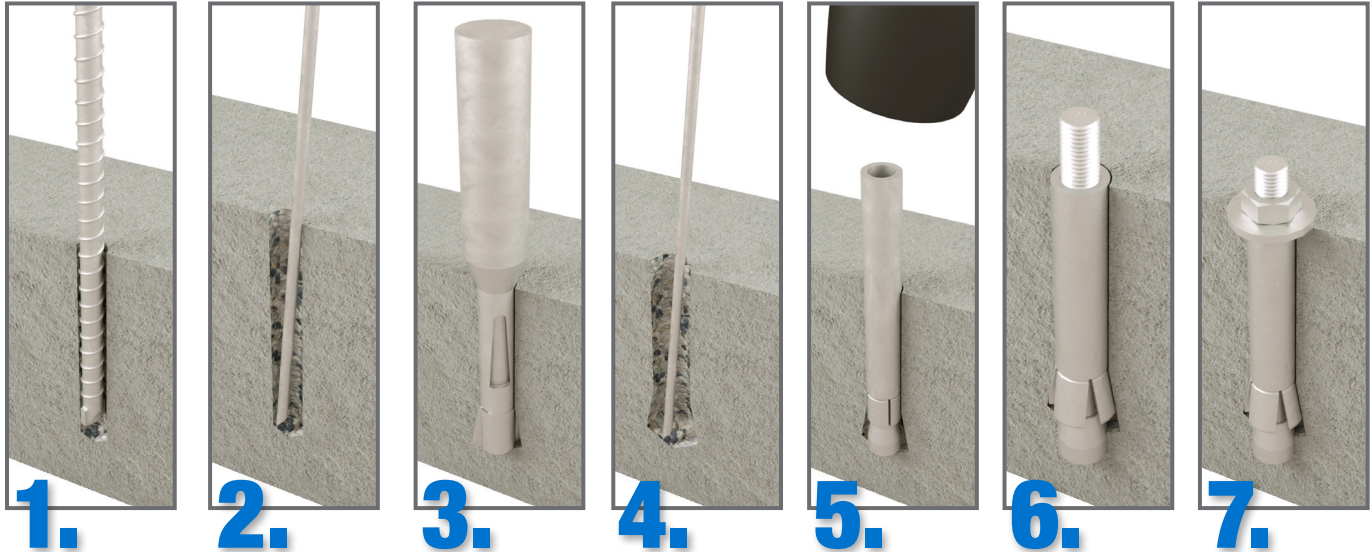

**1.** Drill the hole to proper depth and diameter per specifications using rotohammer and stop drill bit.

**2.** Clean the hole using a blow-out bulb or compressed air.

**3.** Insert the undercut bit and start rotohammer. Undercutting is complete when the stopper sleeve is fully compressed (gap closed).

**4.** Clean the hole again using a blow-out bulb or compressed air.

**5.** Insert anchor into hole. Place setting sleeve over anchor and drive the expansion sleeve over the expansion coupling.

**6.** Verify that the setting mark is visible on the threaded rod above the sleeve.

**7.** Apply proper torque.

### Stop Drill Bit

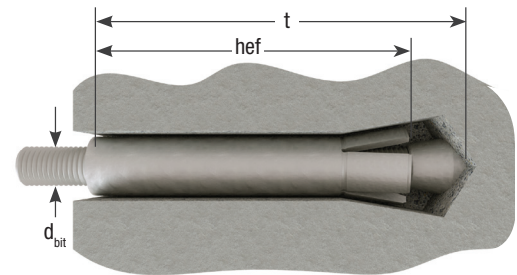

### Stop Drill Bit Dimensions

Stop Drill Bit Designation	Corresponding Anchor Catalog Number	Maximum Drilling Depth, t (inches)	$d_{bit}$ (inches)	Shank Type
DUCSB38-275	DUC38-275	3-1/4	5/8	SDS
DUCSB38-400	DUC38-400	4-1/2	5/8	SDS
DUCSB12-400	DUC12-400	4-9/16	3/4	SDS
DUCSB12-500	DUC12-500	5-9/16	3/4	SDS
DUCSB12-675	DUC12-675	7-5/16	3/4	SDS
DUCSB58-450	DUC58-450	5-7/16	1	SDS-Max
DUCSB58-750	DUC58-750	8-7/16	1	SDS-Max
DUCSB58-900	DUC58-900	9-9/16	1	SDS-Max
DUCSB34-500	DUC34-500	6	1-1/8	SDS-Max
DUCSB34-1000	DUC34-1000	11	1-1/8	SDS-Max

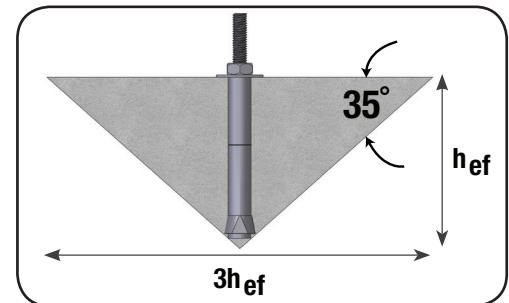

The DUC Undercut Anchor behaves nearly identically to a cast-in-place bolt. The standard embedments listed ensure that the capacity of the concrete exceeds that of the steel at the listed spacings and edge distances.

The capacity of DUC anchors including capacities for close spacing, edge conditions, and cracked concrete can be calculated using the provisions of ACI 318 Appendix D.

# Installation Details and Allowable Loads for DUC Undercut Anchors

Catalog No.	Stud dia. $d_b$	Sleeve dia. $d_s$	Drill hole dia. $d_{bit}$	Drill hole depth $t$	effective embed. $h_{ef}$	Max fastening thickness $t_{fix}$	Overall Length, $l_b$	Sleeve length $l_s$	Allowable Tensile Capacity, $N_s$	Allowable shear capacity $V_s$
38-275L	3/8	5/8	5/8	3-1/8	2 3/4	1-3/4	6	2-3/4	2087	1043
38-275LT	3/8	5/8	5/8	3-1/8	2 3/4	1-3/4	6	4-1/2	2087	1043
38-400H	3/8	5/8	5/8	4-3/8	4	1-3/4	7-1/2	4	4497	2254
38-400HT	3/8	5/8	5/8	4-3/8	4	1-3/4	7-1/2	5-3/4	4497	2254
12-400L	1/2	3/4	3/4	4-3/8	4	1-3/4	7-1/2	4	3821	1909
12-400LT	1/2	3/4	3/4	4-3/8	4	1-3/4	7-1/2	5-3/4	3821	1909
12-500H	1/2	3/4	3/4	5-3/8	5	1-3/4	8-1/2	5	8235	4111
12-500HT	1/2	3/4	3/4	5-3/8	5	1-3/4	8-1/2	6-3/4	8235	4111
12-675H	1/2	3/4	3/4	7-1/8	6 3/4	1-3/4	10-1/4	6-3/4	8235	4111
12-675HT	1/2	3/4	3/4	7-1/8	6 3/4	1-3/4	10-1/4	8-1/2	8235	4111
58-450L	5/8	1	1	5-1/8	4 1/2	1-3/4	8-3/8	4-1/2	6086	3047
58-450LT	5/8	1	1	5-1/8	4 1/2	1-3/4	8-3/8	6-1/4	6086	3047
58-750H	5/8	1	1	8-1/8	7 1/2	1-3/4	11-3/8	7-1/2	13116	6552
58-750HT	5/8	1	1	8-1/8	7 1/2	1-3/4	11-3/8	9-1/4	13116	6552
58-900H	5/8	1	1	9-5/8	9	1-3/4	13	9	13116	6552
58-900HT	5/8	1	1	9-5/8	9	1-3/4	13	10-3/4	13116	6552
34-500L	3/4	1-1/8	1-1/8	5-5/8	5	1-3/4	9	5	9007	4497
34-500LT	3/4	1-1/8	1-1/8	5-5/8	5	1-3/4	9	6-3/4	9007	4497
34-1000H	3/4	1-1/8	1-1/8	10-5/8	10	1-3/4	14	10	19411	9692
34-1000HT	3/4	1-1/8	1-1/8	10-5/8	10	1-3/4	14	11-3/4	19411	9692

**NOTES:**

- The tabulated values are for anchors installed at the specified spacing (s) and edge (c) distances. Spacing and edge distances may be reduced using the provisions of ACI 318-11 Appendix D for the 2012 IBC and IRC.
- Contact USP for custom lengths and stainless steel options.

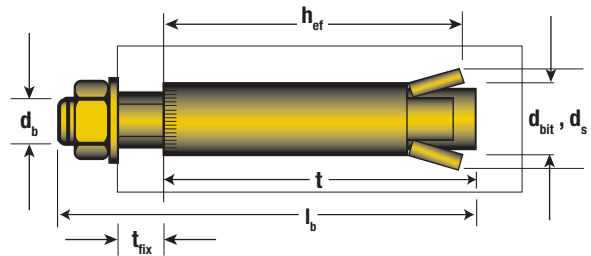

## UBC Series Undercut Drill Bits



## Undercutter Bits for DUC Undercut Anchors

Catalog Number	Use With Anchors	Diam. (inches)	Shank Type	Max. Drilling Depth (inches)	Require Drill Impact Energy (ft. lbs)
UCB58	DUC38-275L DUC38-400H	5/8	SDS	9	1.6
UCB34	DUC12-400L DUC12-500H	3/4	SDS	10-1/4	2.5
UCB100	DUC58-450L DUC58-750H DUC58-900H	1	SDS	12-1/4	3.2
UCB118	DUC34-500L DUC34-1000H	1-1/8	SDS-Max	13-1/2	4.0
UCB118L	DUC34-500L DUC34-1000H	1-1/8	SDS-Max	29-1/2	4.0

## Replacement Parts for DUC Undercutter Bit

Undercutter Drill Bit	Replacement Bow Jaw	Replacement Cutterblade
UCB12	BJ12	CB12
UCB58	BJ58	CB58
UCB34	BJ34	CB34
UCB78	BJ78	CB78
UCB100	BJ100	CB100
UCB118	BJ118	CB118
UCB118L	BJ118L	CB118

To change the cutter blade or bow jaw, do not loosen the set screw on the stopper sleeve. Push the detent pin through the stopper sleeve from the side opposite the set screw until it stops. The bow jaw can now be pulled out. Reverse for reassembly.

## Customer Service:

1-800-328-5934 • [uspcustomerservice@mii.com](mailto:uspcustomerservice@mii.com)  
[www.uspconnectors.com](http://www.uspconnectors.com)