

Service Bulletin

Machinery Affected: BLADE™ Wood Processing System
Document: SB220
Title: Replacing the Outfeed Clamp Assembly
Distribution: Customers - All



Copyright © 2015 MiTek®. All rights reserved.

MiTek Machinery Division
301 Fountain Lakes Industrial Drive
St. Charles, MO 63301
Phone: 800-523-3380
www.mii.com

Item # and Rev.	SB220
Date Created	17 Nov. 2015
Created By	R. Tucker
Reviewed by	D. Schieffer
Approved by	M. Kanjee
Revision Date	
Revised By	
Approved By	
Applicability	Prior to Oct. 2015
Effectivity	<Frame 98

Purpose and Scope

In an effort for continuous improvement, MiTek has redesigned the outfeed clamp assembly for the equipment listed on the title page. To ensure all existing customers experience the significant benefits of this new outfeed clamp, the assembly and everything needed to install it are enclosed. Follow these instructions carefully to upgrade your existing equipment to include the newest outfeed clamp design.

Overview

The parts included in this kit are shown in Table 1. Please ensure all parts are present before starting this procedure.

Table 1: Parts in SB220KIT

Qty.	Parts In 89640-901	Part #
1	Cylinder assembly	89185-501
1	Outfeed clamp mount	89641-501
1	Outfeed clamp bracket	89642-501
4	Set screw	89645
16	Socket head capscrew M5x16	302135
10	Socket head capscrew M5x25mm	302138
4	3/8-16x1-3/4" socket head cap screw (holds main assy)	326267
1	Bolt, shoulder, 5/16 x 1-1/4"	328031
4	Jam nut 1-14	361670
1	Lock nut, 1/4-20	361986
4	Lock washers (holds main assy)	364042
16	Lock washer, M5	364591
2	Pin 3/16 x 1	395140
4	Bearing block, Hiwin HGH-20	416104
2	Linear rail	416159
1	Shock absorber	447009
10	Nut, Nyloc, M5 x 8	452049
1	Conveyor roller	591097
1	Service Bulletin 220 document	SB220

Before beginning the procedure, gather the supplies listed in Table 2.

Table 2: Gather These Supplies



Lock and tag

Hex key set

Tape & marker

Tape measure

3/16" drill bit and drill

Compressed air and blow nozzle

Small, slotted screwdriver

Socket set



Wrench for jam nut

If you have any questions, call MiTek Machinery Division Customer Service at 800-523-3380.

Procedure





Electrical Lockout/Tagout Procedures

	 WARNING
	<p>ELECTROCUTION HAZARD!</p> <p>Verify that all power to the machine has been turned off and follow approved lockout/tagout safety procedures before performing any maintenance.</p> <p>All electrical work must performed by a qualified electrician.</p> <p>If it is absolutely necessary to troubleshoot an energized machine, follow NFPA 70E for proper procedures and personal protective equipment.</p>

Before performing maintenance on any machine with electrical power, lockout/tagout the machine properly. When working on a machine outside of the machine’s main electrical enclosure, not including work on the electrical transmission line to the machine, follow your company’s approved lockout/tagout procedures which should include, but are not limited to the steps here.

1. Move the LASM as far toward the infeed side of the saw chamber as it will go.
2. Engage an E-stop on the machine.
3. Turn the disconnect switch handle on the machine’s main electrical enclosure to the “off” position. See Figure 1.

	 WARNING
	<p>ELECTROCUTION HAZARD.</p> <p>When the disconnect switch is off, there is still live power within the disconnect switch’s enclosure. Always turn off power at the building’s power source to the equipment before opening this electrical enclosure!</p>

4. Attach a lock and tag that meets OSHA requirements for lockout/tagout.

Figure 1: Lockout/Tagout on the Main Electrical Enclosure

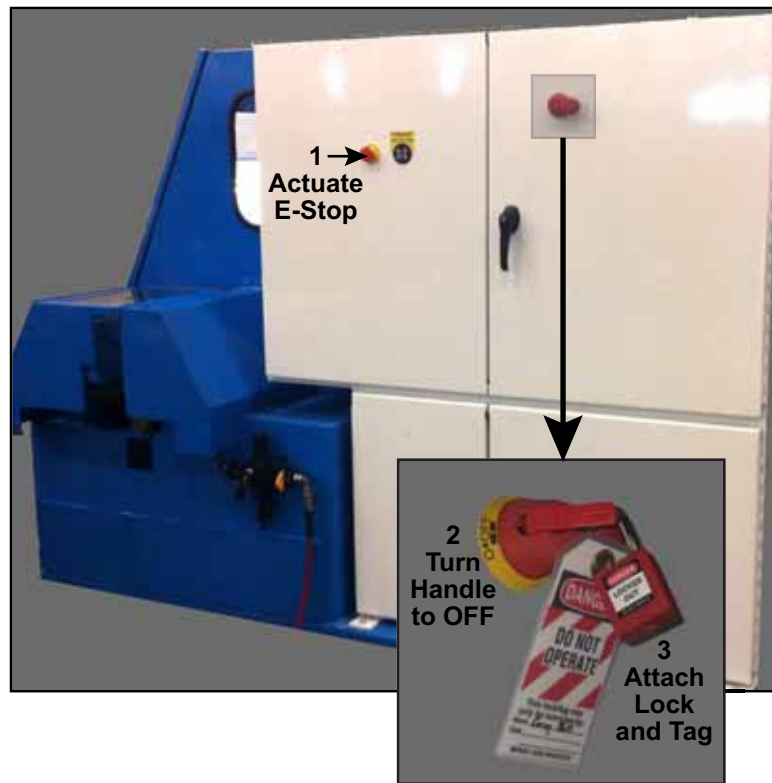

Pneumatic System Lockout/Tagout Procedure

	WARNING
	<p>MOVING PARTS CAN CRUSH AND CUT.</p> <p>Always verify that power to the machine has been turned off and follow approved lockout/tagout procedures.</p> <p>Turn off the air switch before performing any maintenance on the equipment.</p>

	WARNING
	<p>HIGH PRESSURE HAZARD.</p> <p>Bleed pneumatic lines before performing any maintenance on the pneumatic system.</p>

Removing the Existing Outfeed Clamp Assembly

Familiarize yourself with Figure 2 to assist in following these steps to replace the outfeed clamp assembly.

Figure 2: The Parts of the Outfeed Clamp Assembly

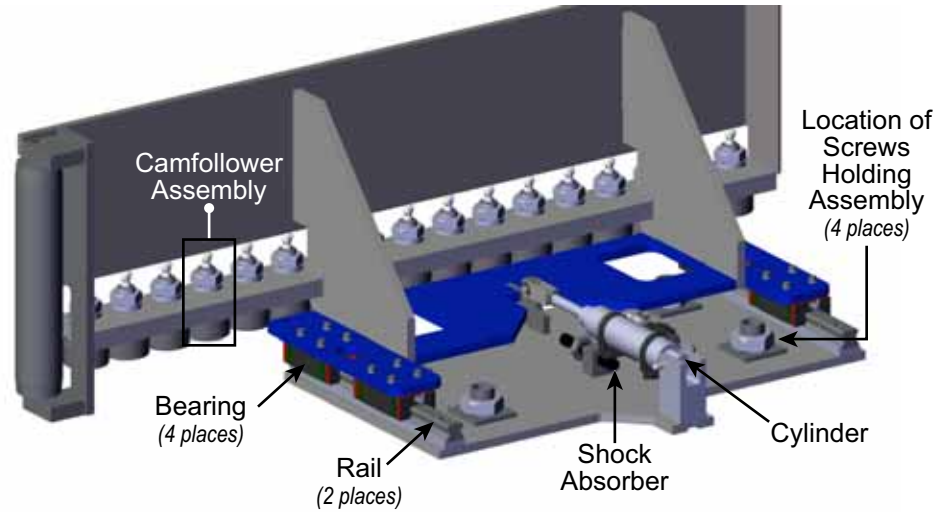

1. Verify the LASM is all the way toward the infeed side of the saw chamber and the electrical power is locked and tagged out.
2. Remove the outfeed clamp assembly by following these steps:
 - a) Remove the guards shown in Figure 3 with a hex key.

Figure 3: Remove These Guards



- b) Remove the 2 sensors shown in Figure 4 from the outfeed clamp cylinder as described:
- 1) Mark each sensor to identify it as “outfeed fully clamped” and “outfeed unclamped”.
 - 2) Document how the wires are attached to the sensor so it can be re-attached in the same way.
 - 3) Inspect the wires and connection to the sensors.
 - If they are in good condition, leave the wires connected and set the sensors aside so they are protected during the rest of the procedure. Keep the supplied sensors in the spare parts kit.
 - If they are not in good condition, remove the wires from the junction box and discard. New sensors and wires are provided.

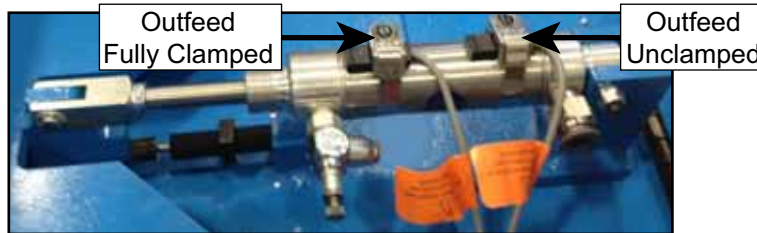

Figure 4: Label and Remove These Sensors From the Cylinder

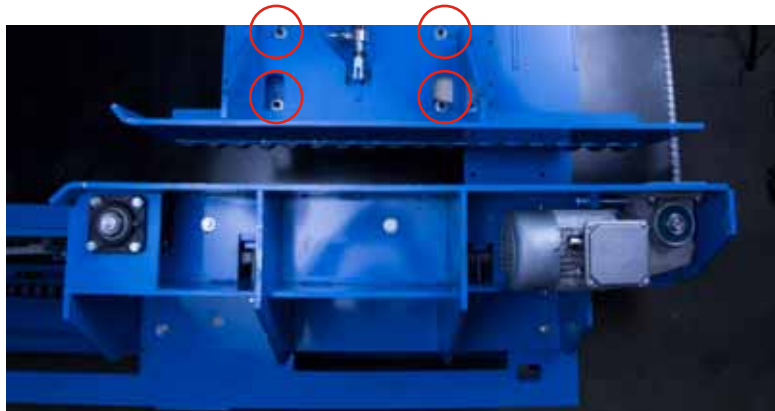

- c) Blow off the entire area to facilitate the rest of this procedure.
- d) Remove the 4 socket-head cap screws shown in Figure 5 with a hex key and remove the lock washers. These can be discarded.

Figure 5: Remove These 4 Screws to Remove Assembly



 CAUTION	
	2-man lift required to safely lift the outfeed assembly! It may weight as much as 120 lb.

- e) Lift off the entire outfeed clamp assembly.
- f) Note the following for spare parts. Refer to Figure 2 for part clarification.
 - Cylinder and shock absorber may be kept for spare parts
 - Discard the linear guide bearings and rails as they are obsolete.

3. Remove all of the cam follower assemblies from the old outfeed clamp assembly so they can be reused:

- a) Loosen and remove the nut shown in Figure 6.
- b) Catch the cam follower (with grease fitting attached) as it falls out when the nut is removed.
- c) Keep the nut, washers, and cam follower.
- d) Repeat for all cam followers.

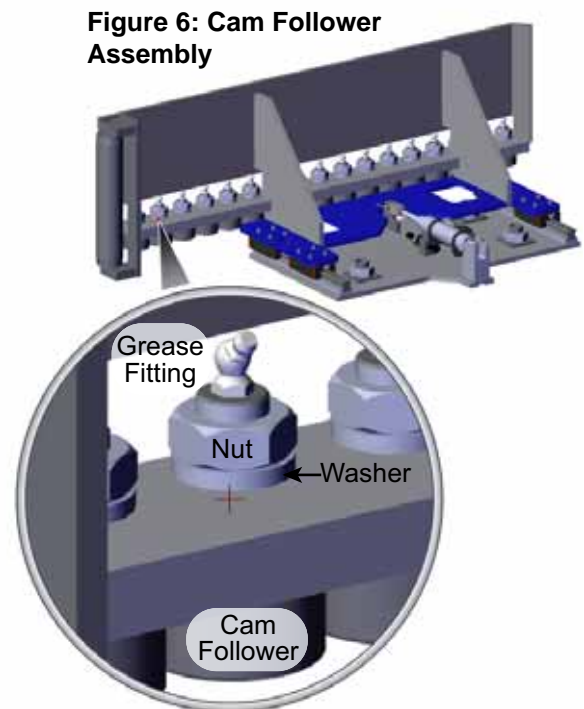

4. Install cam followers into the new outfeed clamp assembly:

- a) Using the hardware just removed, place a washer over a cam follower shaft.
- b) Place the cam follower shaft through a hole in the new outfeed clamp assembly, place a lock washer over the top of the shaft and screw on the nut. Tighten the nut with a hex socket. The shaft has a flat surface to prevent it from spinning while tightening the nut.
- c) Repeat for all cam followers.

Preparing and Installing the New Outfeed Clamp Assembly

1. Measure the fixed jaw of LASM to ensure it is not worn. It must be at least 1-1/2" thick. If worn to less than that, order PN 89145 and install as soon as possible.
2. Prepare the lumber exit chain:

a) Check the lumber exit chain location to ensure it is perfectly parallel with the LASM jaws. All other alignments are measured off of the lumber exit chain, so it must be straight and in a location as described here:

- 1) Lumber exit chain is parallel with the travel rail for LASM fixed jaw and the chain teeth protrude 1/16" in front of the rail.

Check this measurement with LASM at left end of the lumber exit chain, and again with the LASM all the way to the right. Both ends must be identical indicating the lumber exit chain and LASM rail are parallel.

- 2) Channel for the lumber is approximately 2-1/2" wide from tip of chain teeth to surface of cam followers when fully unclamped.

b) If it is necessary to adjust the lumber exit chain, follow these steps:

- 1) Loosen the 3 bolts labeled A in Figure 7.
- 2) Push or pull on the lumber exit chain assembly to align as described previously.
- 3) Tighten the 3 bolts labeled A in Figure 7.

Figure 7: Adjusting the Outfeed Assembly

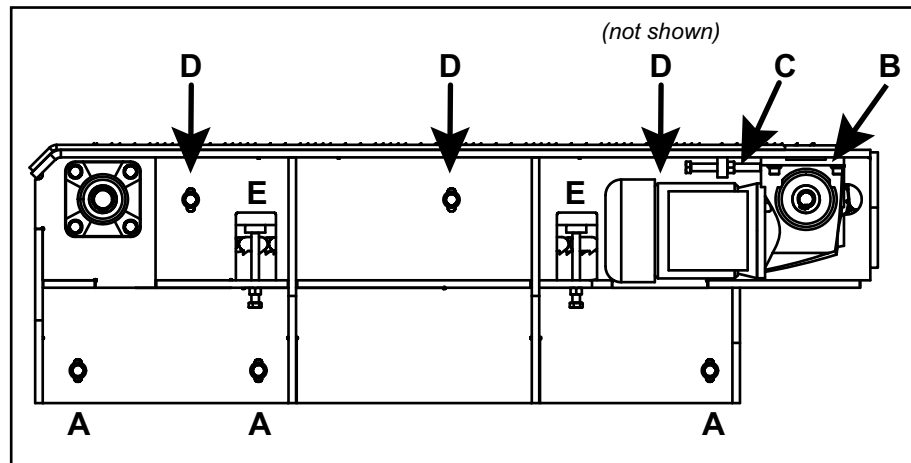

3. Attach new outfeed clamp assembly to saw by following these steps:
 - a) Set the outfeed clamp assembly in place, making sure not to damage the wires, sensors, or air lines.
 - b) Place the four (4) 3/8-16x1-3/4" screws and lock washers provided (PN 326267 & 364042) at the locations show with arrows in Figure 8.
 - c) 3 of the 4 Stand-Off Set Screws are preset. Adjust the 1 Stand-Off Set Screw indicated in Figure 8 until it bottoms out on the base face and stop. Do **not** adjust the other 3 Stand-Off Set Screws.
 - d) Lock the jam nut in for the Stand-Off Set Screw circled in Figure 8.
 - e) Align the outfeed clamp assembly so it is...
 - 1) Parallel to the lumber exit chain.
 - 2) More than 2-1/2" gap between tip of chain teeth and edge of cam followers (with clamp fully retracted). This measurement will be refined with sensor location and shock absorber later.
 - 3) 1-3/8" or less gap when fully extended without board in it.
 - 4) Should be slightly offset between front edge of outfeed clamp cam followers and front edge of powered skewed conveyor cam followers. This can be adjusted on the powered skewed conveyor.
 - f) Tighten all four (4) 3/8-16x1-3/4" screws.

Figure 8: Tightening the Assembly Down

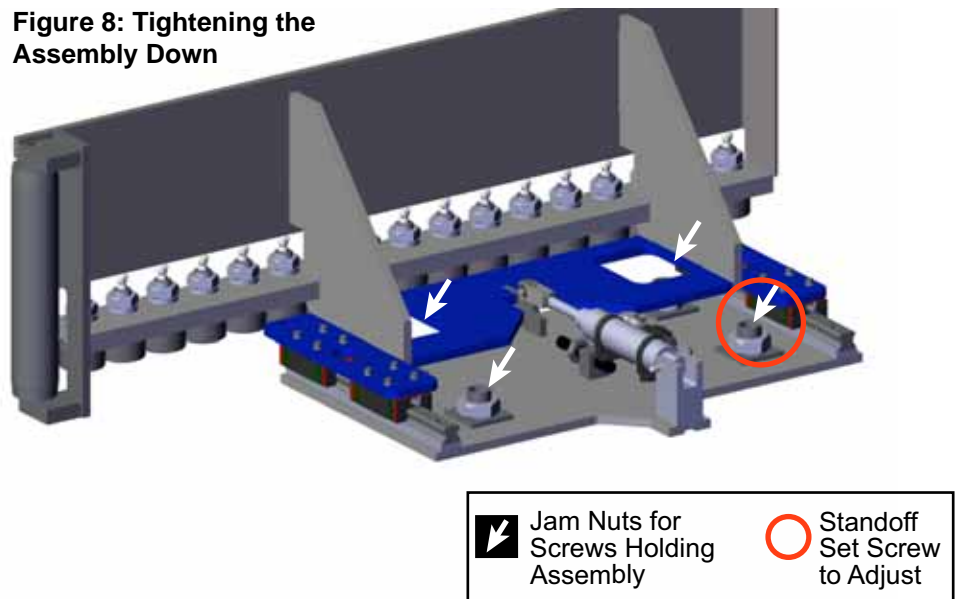

4. Make finite adjustments by adjusting the shock absorber as shown in Figure 9. Ensure the channel is 2-1/2" from tip of chain teeth to surface of cam followers, and verify all other specs listed in step 3e on page 10.

Figure 9: Adjusting the Shock Absorber

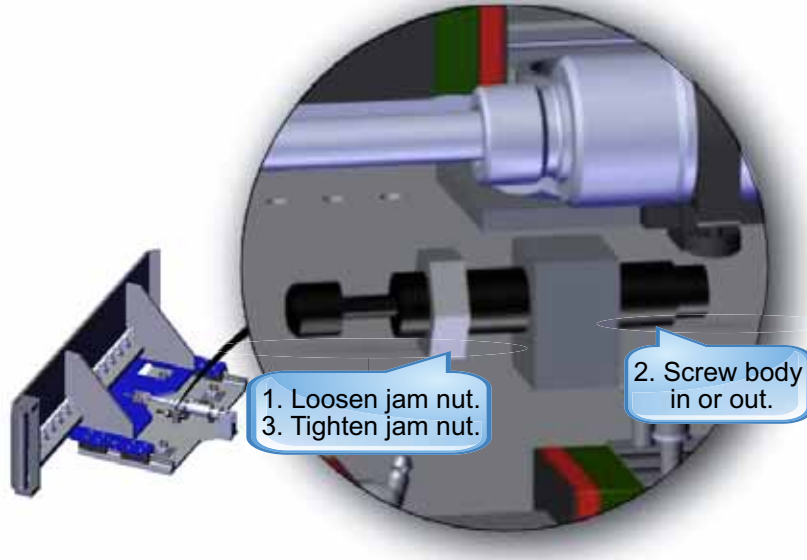

5. Place a board in the LASM and outfeed clamp, then manually clamp both. Ensure the board is securely clamped, verify all rollers and cam followers engage, and everything is aligned.
6. Once everything is aligned, pin the assembly to keep it from slipping.
 - a) Pick any of the three existing outfeed clamp alignment holes shown in Figure 10 and drill a through-hole through the frame directly behind the existing alignment hole. Use a 3/16" drill bit.
 - b) Repeat at the alignment holes on the other end of the outfeed clamp assembly.

- c) Place an enclosed pin in the newly drilled hole on each end to keep the outfeed clamp assembly from slipping on the saw frame.

Figure 10: Place Pin in Alignment Hole

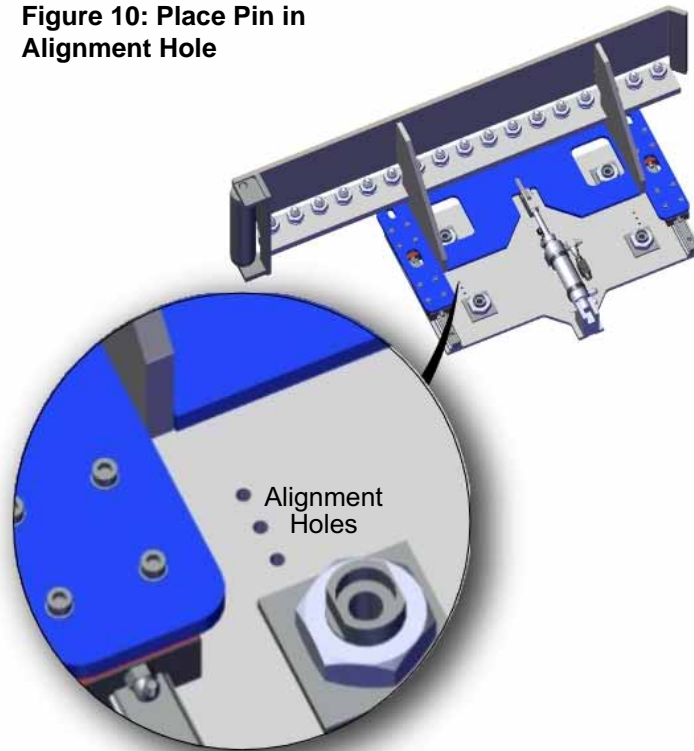

7. If your system has the optional Powered Skewed Conveyor, it is important that it aligns perfectly with the outfeed assembly on the saw.
- a) Check the alignment of the Powered Skewed Conveyor's side guide:
 - 1) It should measure 2-17/32" skatewheel to skatewheel.
 - 2) The skatewheels on the front side of the Powered Skewed Conveyor (closest to the operator) should be even with and in-line with the tips of the outfeed chain.
 - 3) The skatewheels on the back side of the Powered Skewed Conveyor (the side farthest away from operator) must be slightly farther back than the outfeed clamp rollers when retracted.
 - b) If needed, adjust the Powered Skewed Conveyor side guide location:
 - The short side of the Powered Skewed Conveyor fence is adjustable. The long side is fixed.
 - Depending on which option you have, adjust the short side to the right depth and/or move the entire Powered Skewed Conveyor using the slots in the feet.

8. Install the sensors. They are shown in Figure 11. Refer to the electrical drawing 90615-501 located in your Equipment Manual if necessary.

Figure 11: Sensors

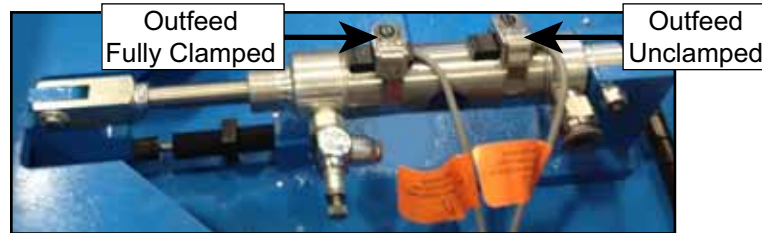

- a) Inspect the old sensors. If the sensors and wiring are in good condition:
 - 1) Remove the new sensors from the new cylinder and keep in the spare parts kit.
 - 2) Attach the old sensors to the new cylinder as shown in Figure 11.
- b) If you prefer to use the new sensors:
 - 1) Remove the old sensor wiring from the turk block near the ink supplies chamber on the saw. Discard the sensors and wiring, or keep in you spare parts kit.
 - 2) Connect the new sensors (already attached to the new cylinder) to the turk block near the ink supplies chamber on the saw.
- c) Remove the lockout/tagout devices, and use precautions for working with powered equipment.
- d) Once everything is in place, adjust the sensors so that:
 - 1) The outfeed unclamped sensor light comes on with clamp fully retracted.
 - 2) The outfeed fully clamped sensor light comes on when fully clamped with no lumber in it.
- e) Cycle a few times to make sure the sensors turn on and off correctly.

Cleaning the Outfeed Clamp Area

Use compressed air to blow off the outfeed clamp area of the saw each shift.



1. Lockout/tagout and shut off air to saw. Allow the air lines to bleed stored air so you can manually move pneumatic components.
2. Manually push the outfeed clamp to its fully extended position and blow off the exposed area behind the clamp fence.

Maintaining Your New Linear Bearings

The linear guide bearings supplied on the new outfeed clamp assembly differ from the bearings previously supplied. These require grease using a standard grease fitting. It is very important that the proper amount of grease is used and the frequency is adequate. All employees responsible for maintaining the BLADE wood processing system must be trained with the information in this section.

THE BEARINGS WERE GREASED BEFORE SHIPPING. Follow these instructions for re-greasing, in approximately 1 week.

Figure 12: Important Parts of Each Bearing Block

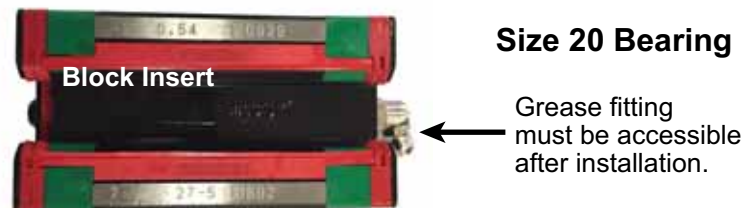

Holes for attaching to plate are on opposite side.

Grease Required

Type of Grease

- *Mobilux*TM EP 2
- Amount of Grease: 0.5 cm³

NOTICE	
	<p>Other Grade 2 greases will not provide the necessary properties at the high temperatures experienced in this application. Use only the recommended grease.</p>

Frequency

Check the quality of the lubrication on the guide rails every week to determine when more grease is needed. The frequency of greasing depends on many factors including amount of use and amount of dust. After enough time has passed to determine a pattern, document how often the bearings should be greased, but continue to inspect the rails every week.

Internal Procedure

For re-greasing the new bearings with the grease fitting, it is highly recommended to either use the grease gun recommended on page 15 or to create an internal procedure stating the exact grease gun that should be used and how many times to pump the gun handle to administer the correct volume of grease.

NOTICE	
	<p>Add grease to these new bearings periodically to ensure saw accuracy and prevent friction from damaging components.</p> <p>Overgreasing will cause premature failure of bearing seals and excessive saw dust and dirt to stick to the guide rails, negating the benefits of the grease. Undergreasing may cause damage to components and affect the accuracy of the saw. A thin film of grease should be visible on the guide rails at all times.</p>

Grease Gun Recommended

It is recommended to use the following grease gun to ensure the proper amount of grease is applied. If you do not have this grease gun available for this procedure, it is recommended that you purchase one for future use. These bearings will require re-greasing at frequent intervals. Having a policy stating the grease gun and number of pumps to use on each bearing will elongate their life and the accuracy of the saw.

Hiwin GN-80M
 Output: 0.5-0.6 cm³ per stroke

If you choose to use a different grease gun, document which gun is to be used for this procedure and ensure employees know the output per stroke. The output per stroke should be equal to or less than 0.5 cm³ per stroke.

END OF SERVICE BULLETIN