



Attachment of Sole Plate to Rim Board with Structural Screws to Resist Lateral Load

MiTek WS and WSTS Structural Screws can be used to transfer lateral shear loads from the sole plate into the rim board. Screws are to be installed into the wide face of the single or double 2x sole plate, through the floor sheathing and into the center of the narrow face of the rim board.

Finish: Yellow Zinc or Exterior Coat (EXT)
Patent: U.S. Patent No. 10,823,218 (WSTS)

Installation:

- The wall and rim board are to be designed to resist lateral loads by a licensed professional.
- Install MiTek WS or WSTS screws through sole plate and floor sheathing and into the rim board using a 3/8" head or T30* driver.
- Follow the minimum spacing and edge distance guidelines per table footnotes shown below.
- Care should be taken to install the screws only where sole plate and rim board are free of any defects.



MiTek Stock No.	Finish ¹	Member Type		Allowable Loads (Lbs.)
		Bottom Plate	Rim Board	Shear 100% (Per Screw)
WS45	Zinc	SPF	LSL	288
WS6 ¹¹			LVL	256
WS45-EXT	EXT	DF	SPF	275
WS6-EXT ¹¹			DF	291
WSTS45-EXT	EXT	SPF	DF	278
WSTS6-EXT ¹¹			SPF	275

- 1) Zinc = Yellow Zinc Dichromate; EXT = Exterior Coat.
- 2) Allowable loads are based on testing and analysis per ICC-ES AC233.
- 3) Allowable loads above are shown with a load duration factor of 1.00.
As permitted by the building code, loads may be increased up to 60%.
- 4) LVL and LSL rim board minimum thickness 1-1/4".
- 5) DF and SPF values assume solid sawn 2x (1-1/2") members.
- 6) DF values may be used in SP installations.
- 7) Minimum spacing for WS and WSTS screws is:
 3" on center on the narrow face of a solid sawn rim board
 6" on center on the narrow face of EWP products
- 8) For WS screws, the minimum end distance is 3-1/2" and the minimum edge distance is 5/8".
- 9) For WSTS screws, the minimum end distance is 2-1/4" and the minimum edge distance is 5/8".
- 10) Maximum floor sheathing thickness of 3/4".
- 11) 6" length WSTS6 and WS6 shall be used when a double sole plate is present with no change to load values in table.

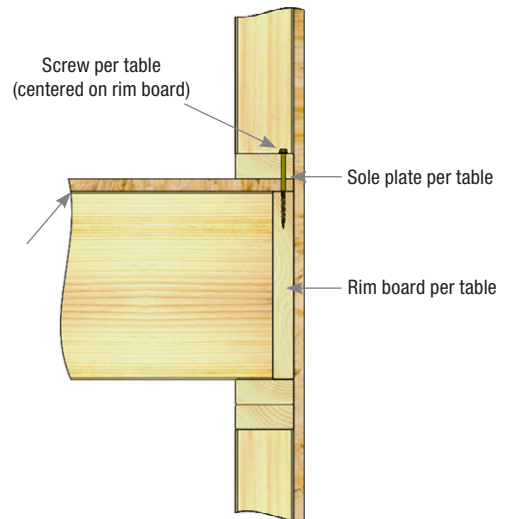

Typical 2x4 sole plate attached to DF rim board through 1/2" sheathing

*T30 is a trademark of Acument

Customer Service & Technical Assistance

Phone: 1-800-328-5934 • **Fax:** 1-952-898-8605 • **Email:** USPcustomerservice@mii.com