

Operation and Maintenance Manual



Roller Gantry

With *MiTek*[®], *Tee-Lok*[®], or *Robbins Tables*

Operation and Maintenance Manual

Roller Gantry

With *Mitek*[®], *Tee-Lok*[®], or *Robbins Tables*



U.S. and other patents pending.

MiTek
Machinery Division
301 Fountain Lakes Industrial Drive
St. Charles, MO 63301
phone: 800-523-3380
fax: 636-328-9218
www.mii.com

Part Number	001012
Print Date	December 19, 2023
Revision	C
Revision Date	4 June 2008
Revised By	R. Widder
Approved By	R. Tucker
Applicability	PN 68000-(?)V
Effectivity	All

Contents

Preliminary Pages

Contents	ii
Legal Notice	v
Notice of Change	vi

Safety (English)

Safety Indicators	viii
Safety Rules	ix
Lockout/Tagout	xi
Lockout/Tagout Guidelines	xi
Electrical Lockout/Tagout Procedures	xii
Pneumatic System Lockout/Tagout Procedure	xv
Troubleshooting With an Energized Machine	xv
Restricted Zone	xvi

Seguridad (Español)

Indicadores de seguridad	xviii
Reglas de seguridad	xix
Bloqueo/Etiquetado	xxii
Pautas de bloqueo/etiquetado	xxii
Procedimientos de bloqueo/etiquetado eléctricos	xxiii
Procedimiento de bloqueo/etiquetado del sistema neumático	xxvi
Solución de problemas con una máquina energizada	xxvii
Zonas restringida	xxviii

Introduction

Chapter 1

Introduction to the Manual	1
Purpose and Scope of This Equipment Manual	1
Navigation	2
Additional Resources	3
Supplemental Documentation	3
Web Site	3
Contacting MiTek	3

General Information

Chapter 2

Introduction to the Equipment	4
Purpose of the Equipment	4
Description of the Equipment	4
General Specifications	6
Truss Terminology	8

Prior to Installation

Chapter 2

MiTek's Responsibilities	10
Prior to Installation	10
During Installation	10
Customer Responsibilities	11
Location Requirements	11

Contents

Electrical Requirements	12
Training Provided	12
Installation	Chapter 3
Responsibilities During Installation	13
Delivery	13
Checking for Damage	13
Unloading	14
Unpacking	14
Equipment Layout	15
Assembly	15
Forklift	16
Electrical System	16
Checking Existing Wiring	16
Connecting Power to the Equipment	16
Installation Checklist	17
Operation	Chapter 5
Safety Hazards During Operation	18
Stopping the Machine	19
Starting the Machine	20
Operator Control Interface	21
Operating Procedure	22
Safety	22
Procedure Under Normal Conditions	23
Maintenance	Chapter 6
Introduction to Maintaining Your Equipment	24
Performing Maintenance Safely	25
Before Operating This Equipment	25
Lockout/Tagout	25
Making Adjustments	26
Replacing Parts	26
Wearing Personal Protective Equipment	26
Conducting Safety Tests	26
Overview Graphics	27
Adjustments	28
Adjusting the Speed Reducer/Gearbox Chain	28
Adjusting the Drive Wheel Chain	28
Aligning/Adjusting the Sprocket	29
Adjusting the QD Sprocket	29
Adjusting the Bogie Wheels	32
Adjusting the <i>Roller Gantry</i> Roller Setting	32
Checking Operation of the <i>Roller Gantry</i>	33
Cleaning, Lubricating, and Inspecting	36
Cleaning	36
Lubricating	37
Motors and Gearboxes	38
Electric Motor and Soft-Start™ Clutch	40

Contents

Cleaning, Inspecting, and Replacing the Soft-Start Clutch Pad	40
Replacing the Motor	41
Brake	42
Replacing the Magnetic Disc Brake Lining	43
Parts List	
Appendix A	46
Safety Notes for Replacing Parts	46
Part Numbers	47
Technical Information	
Appendix B	48
Understanding Overloads	48
Understanding Motor Starting Problems	58
Voltage Source Problems	58
Control Circuit Problems	59
Drive Faults	59
Drawing Set	
Appendix C	60
Document Evaluation	
Appendix D	61
Glossary	64
Index	68

Legal Notice

Patents

Made and sold under one or more of the following patents:

U.S. 37,797	U.S. 5,468,118
U.S. 5,553,375	U.S. 6,079,325
U.S. 6,145,684	U.S. 6,330,963
U.S. 6,405,916	U.S. 6,651,306
U.S. 6,807,903	Other Patents Pending

Return Goods Policy

Return goods cannot be accepted without prior authorization and are subject to a restocking charge. The Seller certifies the articles specified herein were produced in compliance with all provisions of the Fair Labor Standards Act of 1938, as amended, including Section 12.—Rev. 6/98

Reporting Errors and Recommending Improvements

To report errors or recommend improvements to this manual, please complete the Document Evaluation Form in the appendices. Mail or fax the form to:

MiTek, Machinery Division
301 Fountain Lakes Industrial Drive
St. Charles, MO 63301
Attn: Engineering Manager
Fax: 636-328-9218

Your support in helping MiTek provide unsurpassed machinery and support is appreciated.

Safety (English)

For safety information in Spanish, refer to page v.

**Be Careful.
Be Safe.**



Safety Indicators

The following safety alert symbols and signal words are used throughout this document to indicate safety hazards. Please pay careful attention when you see them. The level of severity differs for each symbol or signal word. The definitions below can also be found in ANSI z535.4-2002.

Failure to comply with the instructions accompanying each safety alert symbol may result in property damage, personal injury, or even death. Personnel must follow all safety procedures and practices to ensure the safest possible operation of this equipment. However, at no time is this document a substitute for common sense. Personnel must ensure that the work environment is safe and free of distractions.



DANGER

Indicates an imminently hazardous situation which, if not avoided, will result in death or serious injury.



WARNING

Indicates a potentially hazardous situation which, if not avoided, could result in death or serious injury.



CAUTION

When CAUTION is used *with* the safety alert symbol shown here, it indicates a potentially hazardous situation which, if not avoided, may result in minor or moderate injury.

When CAUTION is used *without* the safety alert symbol shown here, it indicates a potentially hazardous situation which may result in equipment damage.



NOTICE

Calls attention to information that is significant to understanding the operation at hand.



ENVIRONMENTAL

Applies to conditions that may affect the environment but do not have an immediate, direct effect on personnel or equipment.

Safety Rules

Because it is impossible to anticipate every circumstance that might involve a hazard, the safety information provided in this equipment manual and on the machine is not all-inclusive. If this machine is operated or serviced using a procedure not specifically recommended by the manufacturer, the procedure shall be approved by a professional engineer to ensure it will not render the equipment unsafe. Use extreme caution and common sense at all times!

Know Your Equipment

- Read this manual completely before using or maintaining the equipment. Do not operate this machine unless you have a thorough knowledge of the controls, safety devices, emergency stops, and operating procedures outlined in this manual.
- Read and follow all safety notes. Failure to comply with these instructions may result in economic loss, property damage, and/or personal injury including death.
- Refer to the lockout/tagout guidelines on the following pages to safely perform maintenance and troubleshooting of this equipment.
- Observe and obey all safety labels. Replace worn labels immediately.
- Use this equipment solely for the purpose described in this manual.
- Only qualified personnel should attempt to operate or perform maintenance on this equipment. “Qualified personnel” is defined as:

...a person or persons who, by possession of a recognized degree or certificate of professional training, or who, by extensive knowledge, training, or experience, has successfully demonstrated the ability to solve problems relating to the subject matter and work—ANSI B30.2-1983

...one who has skills and knowledge related to the construction and operation of the electrical equipment and installations and has received safety training on the hazards involved—NEC 2002 Handbook

Personal Safety

- Always wear safety glasses and hearing protection in an industrial environment.
- Utilize a filtering facepiece (dust mask) when working near sawdust.
- Wear proper clothing and appropriate personal protective equipment (e.g., safety glasses and hearing protection.) Do not wear loose clothing or jewelry. Confine long hair by tying it back.
- Use caution when lifting heavy parts or material.

Installing the Equipment

- Follow installation instructions completely.

Lockout/Tagout

- Before performing maintenance on the pneumatic or hydraulic systems, bleed the lines to eliminate pressure.
- Lockout/tagout all energized systems before performing maintenance on them. Refer to the *Lockout/Tagout Guidelines* section on page ix.

Keeping a Safe Environment

- Keep children away. All visitors should be kept a safe distance from the work area. Hazards may not be apparent to individuals unfamiliar with the machine.
- Keep work areas well lit.
- Keep the work area clean and free of any trip or slip hazards.
- Do not use the equipment in damp or wet locations, or expose it to rain or snow.

Operating and Maintaining the Equipment

- Ensure that all people, tools, and foreign objects are clear of the restricted zones before operating this equipment. The restricted zones are shown on page xiv.
- Perform safety tests to ensure all E-stops are working properly before operating the equipment at the initial startup, after performing any maintenance, and in accordance with the maintenance schedule.
- In case of machine malfunction, stop the machine immediately using an E-stop and report the malfunction to a supervisor.
- Never leave the machine running unattended. Turn the power off! Do not leave the machine until all parts have come to a complete stop and all electrical power has been shut off.
- Check for worn or damaged parts regularly. Repair or replace them immediately.
- Keep the hydraulic, pneumatic, and electrical systems in good working order at all times. Repair leaks and loose connections immediately. Never exceed the recommended pressure or electrical power.
- Check that all safety devices are in working order before each shift starts. All protective guards and safety devices must be in place before and during use of the machine. Never disconnect or bypass any safety device or electrical interlock.
- Periodically inspect the quality of the finished product.

Electrical Safety

- Do not use any liquids in the interior of electrical cabinets.
- When using solvents on and around the machine, remove power to the machine to eliminate the chance of sparking, resulting in explosion or fire. Wear a respirator approved for use with solvents. Wear protective clothing, gloves, and safety glasses.

Lockout/Tagout

Lockout/Tagout Guidelines

All lockout/tagout guidelines must be met according to OSHA 29 CFR 1910.147. A specific procedure should be included in your company's energy control program. This manual is not intended to replace your company's de-energizing or lockout/tagout procedure required by OSHA, but merely to provide general guidance.

The term "lockout," as used in this manual, means placing a lockout device on any and all energy sources to ensure that the energy isolating device and the equipment being controlled cannot be re-energized or operated until the lockout device is removed. The photos on the next page show where the electrical disconnects are located for this machine.



- Energy sources include electrical, mechanical, hydraulic, pneumatic, chemical, thermal, or other energy.
- In the case of electrical energy sources, the main power and control power to the machinery must be turned off and physically locked in the "off" position.
- A lockout device is usually a keyed padlock.
- If more than one person is working in a restricted zone, use a group lockout device that will allow each person to use a lock that can be removed only by the person performing the maintenance.

"Tagout" means that a prominent warning is securely fastened to an energy-isolating device to indicate that the equipment shall not be operated.

Electrical Lockout/Tagout Procedures

When Working on a Machine Outside the Machine’s Main Electrical Enclosure



If working on the electrical transmission line to the machine, follow the procedure on page xii.

Before performing maintenance on any machine with electrical power, lockout/tagout the machine properly. When working on a machine outside of the machine’s main electrical enclosure, not including work on the electrical transmission line to the machine, follow your company’s approved lockout/tagout procedures which should include, but are not limited to the steps here.

1. Engage an E-stop on the machine.
2. Turn the disconnect switch handle to the “off” position. See Figure 2-1.

WARNING	
	<p>ELECTROCUTION HAZARD.</p> <p>When the disconnect switch is off, there is still live power within the disconnect switch’s enclosure. Always turn off power at the building’s power source to the equipment before opening this electrical enclosure!</p>

3. Attach a lock and tag that meet OSHA requirements for lockout/tagout.
4. Restrain or de-energize all pneumatic components, hydraulic components, and other parts that could have live or stored power.

Figure iv-1: Lockout/Tagout on the Main Electrical Enclosure

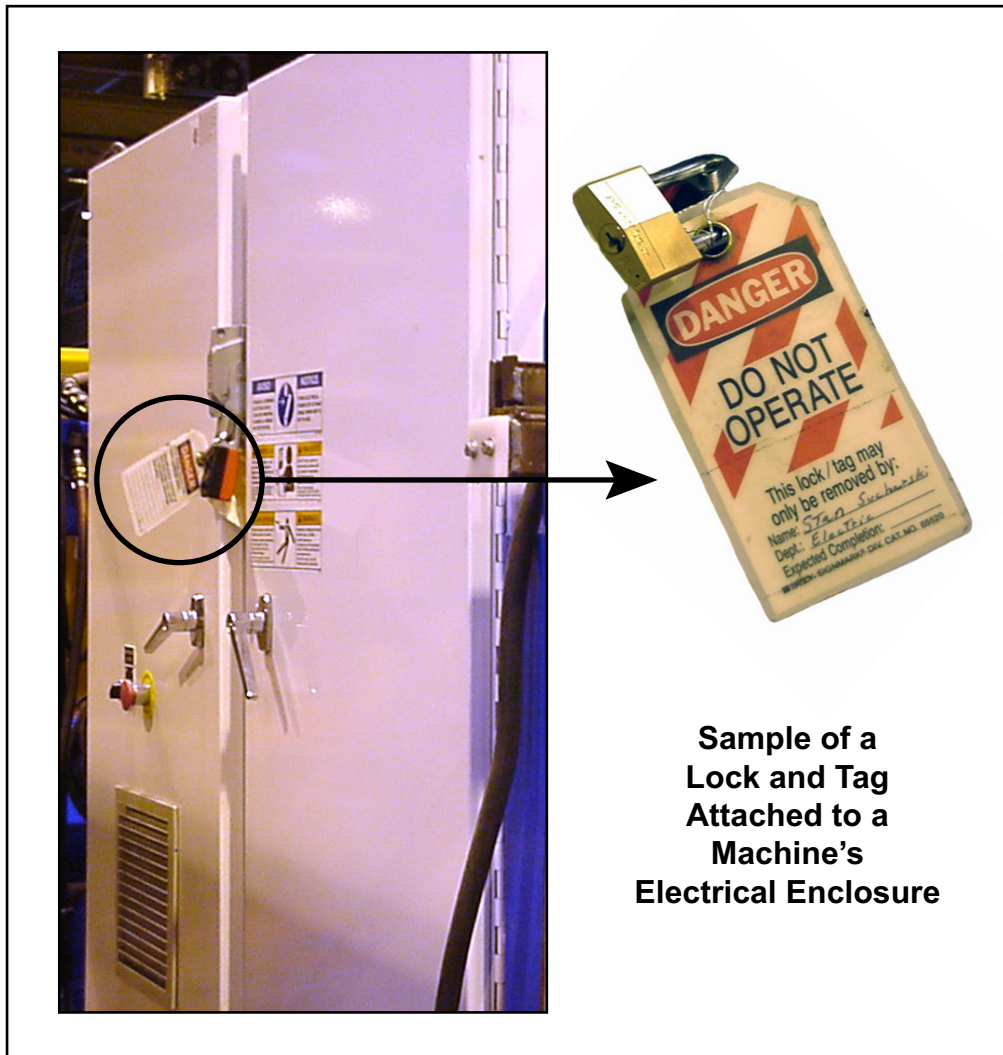

When Working on a Machine Inside the Machine's Main Electrical Enclosure or in the Electrical Transmission Line to the Machine

Before opening the main electrical enclosure, or attempting to repair or replace an electrical transmission line to the machine, lockout/tagout the machine properly. Follow your company's approved lockout/tagout procedures which should include, but are not limited to the steps here.

1. Engage an E-stop on the machine.
2. Shut the power to the machine off at the machine's power source which is usually an electrical service entry panel on the facility wall. One example of a locked-out power source panel is shown in Figure 2-2.
3. Attach a lock and tag that meets OSHA requirements for lockout/tagout.
4. Open the door to the enclosure in which you need access, and using a multimeter, verify that the power is off.

Figure iv-2: Lockout/Tagout on the Power Source Panel



Pneumatic System Lockout/Tagout Procedure

When Lockout/Tagout is Not Required

If working on components other than the pneumatic system, but that requires you to be near the vicinity of movable pneumatic components, you must, at a minimum, physically restrain the pneumatic components from moving. If this is not possible, lockout/tagout the entire pneumatic system.

When Lockout/Tagout is Required

Before attempting repair or maintenance on a pneumatic line or component, lockout/tagout the machine properly. Follow your company's approved lockout/tagout procedures.

Troubleshooting With an Energized Machine

Only a qualified electrician, using the personal protective equipment and following the procedures recommended in NFPA 70E should ever attempt service or repair of or near an energized area or component of the machine.

Whenever maintenance is performed while the equipment is electrically energized, there is a potential electric arc flash hazard. Refer to NFPA 70E for the personal protective equipment required when working with electrically energized components. Pneumatic and hydraulic components may move unexpectedly if not de-energized. Physically restrain any components capable of movement when working on or near those components.

Restricted Zone

DANGER	
	<p>Stay clear of the restricted zone when equipment is in use. Serious injury or death may result if personnel are in the restricted zone.</p>

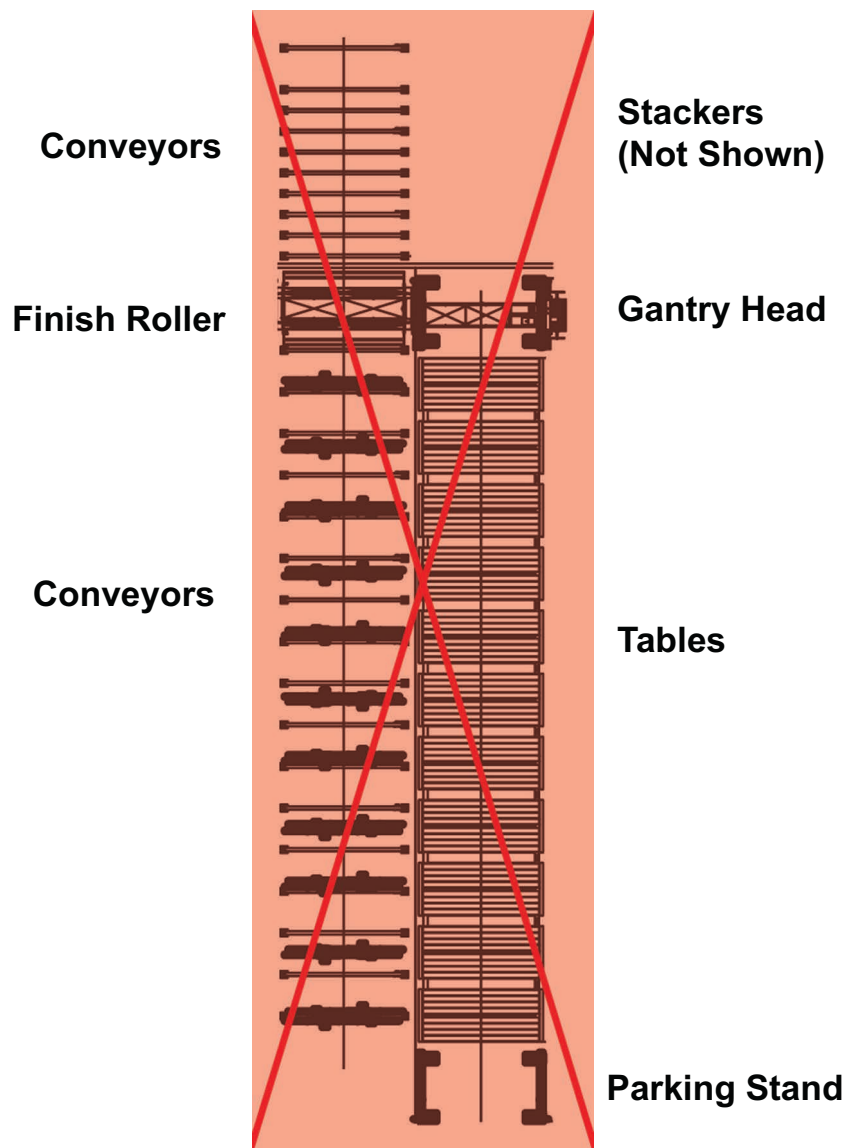

Seguridad (Español)

**Sea cuidadoso.
Protéjase.**



Indicadores de seguridad

Los siguientes símbolos de alerta de seguridad y palabras de advertencia se utilizan a lo largo de este documento para indicar riesgos de seguridad. Preste suma atención cuando los vea. Cada símbolo o palabra indica un nivel de gravedad diferente. Las definiciones incluidas a continuación también pueden consultarse en la norma ANSI z535.4-2002.

El no cumplimiento de las instrucciones que acompañan a cada símbolo de alerta de seguridad puede producir daños a la propiedad, lesiones personales e incluso la muerte. El personal debe seguir todos los procedimientos y prácticas de seguridad establecidos para asegurar el uso más seguro posible de este equipo. No obstante, en ningún caso este documento reemplaza el sentido común. El personal debe asegurarse de que el entorno de trabajo sea seguro y esté libre de distracciones.



PELIGRO

Indica una situación de riesgo inminente que, si no se evita, producirá la muerte o lesiones graves.



ADVERTENCIA

Indica una situación potencialmente peligrosa que, si no se evita, podría producir la muerte o lesiones graves.



PRECAUCIÓN

Cuando la PRECAUCIÓN se utiliza **con** el símbolo de alerta de seguridad aquí ilustrado, indica una situación potencialmente peligrosa que, si no se evita, puede producir lesiones menores o moderadas.

Cuando PRECAUCIÓN se utiliza **sin** el símbolo de alerta de seguridad aquí ilustrado, indica una situación potencialmente peligrosa que podría producir daños al equipo.

AVISO

AVISO

Llama la atención a información importante para entender la operación que se desea realizar.

AMBIENTAL

AMBIENTAL

Se aplica a condiciones que pueden afectar el entorno pero que no tienen un efecto inmediato o directo sobre el personal o el equipo.

Reglas de seguridad

Debido a la imposibilidad de anticipar todas las circunstancias que podrían constituir un riesgo, la información de seguridad suministrada en este manual del equipo y sobre la máquina no es exhaustiva. Si se utiliza o realiza el mantenimiento de esta máquina utilizando un procedimiento no recomendado específicamente por el fabricante, el procedimiento deberá ser aprobado por un ingeniero profesional para asegurarse de que no afecte la seguridad del equipo. ¡Manéjese! siempre con suma precaución y sentido común!

Conozca su equipo

- Lea este manual en su totalidad antes de utilizar o mantener el equipo. No utilice esta máquina a menos que esté perfectamente familiarizado con los controles, los dispositivos de seguridad, los frenos de emergencia y los procedimientos operativos que se describen en este manual.
- Lea y siga todas las notas de seguridad. El no cumplimiento de estas instrucciones podría producir pérdidas económicas, daños a la propiedad y lesiones personales, incluida la muerte.
- Refiérase a las pautas de bloqueo/etiquetado proporcionadas en las siguientes páginas para realizar el mantenimiento y solucionar problemas de este equipo en forma segura.
- Observe y cumpla con todas las etiquetas de seguridad. Cambie las etiquetas gastadas inmediatamente.
- Utilice este equipo únicamente para el propósito que se describe en este manual.
- Sólo personal calificado debe intentar utilizar o realizar el mantenimiento de este equipo. Por "personal calificado" se entiende:

*...una persona o personas que, por el hecho de poseer un título o certificado de capacitación profesional reconocido o que, por sus amplios conocimientos o experiencia, han demostrado con éxito estar capacitados para resolver problemas relacionados con el tema y el trabajo en cuestión
—ANSI B30.2-1983*

...una persona que posee habilidades y conocimientos relacionados con la construcción y uso de equipos e instalaciones eléctricas y que ha recibido capacitación en seguridad sobre los riesgos posibles—NEC 2002 Handbook

Seguridad personal

- Use siempre anteojos de seguridad y protección auditiva en un entorno industrial.
- Utilice una máscara protectora cuando trabaje cerca de aserrín.
- Utilice ropa adecuada y equipo de protección personal apropiado (por ejemplo, anteojos de seguridad y protección auditiva.) No use ropa suelta ni joyas. Si tiene el cabello largo, áteselo para atrás.
- Proceda con precaución cuando levante piezas o materiales pesados.

Instalación del equipo

- Siga las instrucciones de instalación al pie de la letra.

Procedimientos de Bloqueo/Etiquetado

- Antes de realizar el mantenimiento de los sistemas neumáticos o hidráulicos, purgue las líneas para eliminar la presión.
- Bloquee y etiquete todos los sistemas energizados antes de realizar tareas de mantenimiento en ellos. Refiérase a la sección *Pautas de bloqueo/etiquetado* en la página x.

Cómo mantener un entorno seguro

- Mantenga alejados a los niños. Todos los visitantes deben mantenerse a una distancia segura del área de trabajo. Los riesgos pueden no ser evidentes a las personas no familiarizadas con la máquina.
- Mantenga las áreas de trabajo bien iluminadas.
- Mantenga el área de trabajo limpia y libre de cualquier riesgo de tropiezo o resbalamiento.
- No utilice el equipo en lugares húmedos o mojados y no lo exponga a la lluvia o a la nieve.

Uso y mantenimiento del equipo

- Asegúrese de que no haya personas, herramientas y objetos extraños en las zonas restringidas antes de utilizar este equipo. Las zonas restringidas se indican en la página xvi.
- Realice pruebas de seguridad para verificar que todos los frenos de emergencia funcionen adecuadamente antes de utilizar el equipo por primera vez, después de realizar cualquier tarea de mantenimiento y según la frecuencia de mantenimiento establecida.
- En caso de que la máquina no funcione correctamente, deténgala inmediatamente utilizando un freno de emergencia e informe el problema a un supervisor.
- No deje nunca la máquina encendida si no está junto a ella. ¡Apáguela!. No abandone la máquina hasta que todas las piezas se detengan completamente y hasta que se haya apagado la alimentación eléctrica.
- Verifique periódicamente que no haya piezas gastadas o dañadas. Repárelas o cámbielas inmediatamente.
- Mantenga los sistemas hidráulicos, neumáticos y eléctricos en buen funcionamiento en todo momento. Repare las fugas y las conexiones sueltas inmediatamente. No exceda nunca la presión ni potencia eléctrica recomendadas.

- Verifique que todos los dispositivos de seguridad estén en buen funcionamiento al comienzo de cada turno. Todos los dispositivos protectores y de seguridad deben estar en su lugar antes y durante el uso de la máquina. No desconecte ni evite nunca ningún dispositivo de seguridad ni interbloqueo eléctrico.
- Inspeccione periódicamente la calidad del producto terminado.

Seguridad eléctrica

- No utilice líquidos en el interior de los gabinetes eléctricos.
- Cuando utilice disolventes sobre o alrededor de la máquina, desconecte la alimentación para eliminar las probabilidades de chispas, que pueden producir una explosión o incendio. Use un respirador aprobado para el uso con disolventes. Use ropa protectora, guantes y anteojos de seguridad.

Bloqueo/Etiquetado

Pautas de bloqueo/etiquetado

Deben cumplir con todas las pautas de bloqueo/etiquetado conforme a la norma OSHA 29 CFR 1910.147. El programa de control de energía de la compañía debe incluir un procedimiento específico. El objetivo de este manual no es reemplazar el procedimiento de desenergización o bloqueo/etiquetado requerido por la OSHA, sino proporcionar pautas orientativas generales.

El término "bloqueo", según se utiliza en este manual, se refiere a la colocación de un dispositivo de bloqueo en las fuentes de energía para asegurar que el dispositivo aislador de energía y el equipo controlado por éste no puedan reenergizarse o utilizarse hasta que se retire dicho dispositivo.

Las fotos de la página siguiente muestran los lugares en los que se encuentran los interruptores de desconexión eléctrica de esta máquina.



- Las fuentes de energía incluyen energía eléctrica, mecánica, hidráulica, neumática, química, térmica y otras.
- En el caso de fuentes de energía eléctrica, la alimentación principal y la alimentación de control a la maquinaria deben apagarse y bloquearse físicamente en la posición "off" (apagado).
- Por lo general, como dispositivo de bloqueo se utiliza un candado con llave.
- Si hay más de una persona trabajando en una zona restringida, utilice un dispositivo de bloqueo grupal que permita a cada persona utilizar un candado que sólo pueda ser retirado por la persona que realiza el mantenimiento.

"Etiquetado" significa que debe colocarse una advertencia fácil de ver en un dispositivo aislador de energía que indique que el equipo no debe utilizarse.

Procedimientos de bloqueo/etiquetado eléctricos

Cuando trabaja en una máquina fuera del gabinete eléctrico principal de la máquina



Si trabaja en la línea de transmisión eléctrica a la máquina, siga el procedimiento de la página xiii.

Antes de realizar el mantenimiento de cualquier máquina con alimentación eléctrica, bloquee y etiquete la máquina de forma adecuada. Cuando trabaje en una máquina fuera del gabinete eléctrico principal de la máquina, salvo en el caso de trabajos en la línea de transmisión eléctrica a la máquina, siga los procedimientos de bloqueo/etiquetado aprobados por la compañía, los cuales deberían incluir, entre otros, los pasos aquí indicados.

1. Coloque un freno de emergencia sobre la máquina.
2. Coloque el mango del interruptor con fusibles en la posición "apagado/apagada".
Vea la figura 2-1.

	<p>RIESGO DE ELECTROCUCIÓN.</p> <p>Cuando el interruptor con fusibles está apagado, sigue habiendo energía dentro del gabinete del interruptor. ¡Apague siempre la alimentación en la fuente de alimentación del edificio antes de abrir este gabinete eléctrico!</p>

3. Coloque un candado y una etiqueta que cumplan con los requisitos de bloqueo/etiquetado de la OSHA.
4. Trabe o desenergice todos los componente neumáticos, componentes hidráulicos y otras piezas que tengan alimentación directa o almacenada.

Figure v-1: Bloqueo/etiquetado en el gabinete eléctrico principal

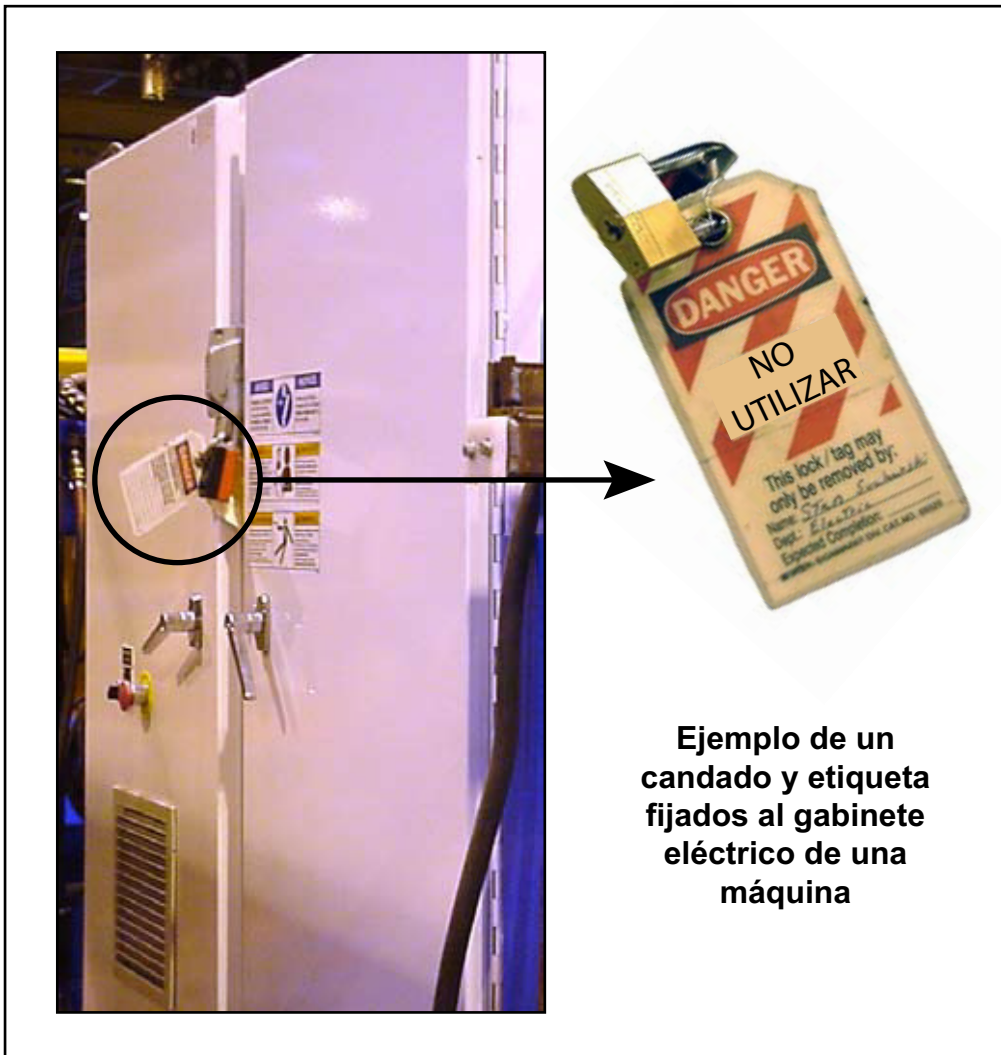

Cuando trabaje en una máquina dentro del gabinete eléctrico principal de la máquina o en la línea de transmisión eléctrica a la máquina

Antes de abrir el gabinete eléctrico principal o intentar reparar o reemplazar una línea de transmisión eléctrica a la máquina, bloquee y etiqueta la máquina en forma adecuada. Siga los procedimientos de bloqueo/etiquetado aprobados por la compañía, los cuales deberían incluir, entre otros, los pasos aquí indicados.

1. Coloque un freno de emergencia sobre la máquina.
2. Apague la alimentación a la máquina en la fuente de alimentación, que, por lo general, es un panel de entrada de suministro eléctrico que se encuentra en una pared de las instalaciones. En la figura 2-2 se muestra un ejemplo de panel de fuente de alimentación bloqueado.
3. Coloque un candado y una etiqueta que cumplan con los requisitos de bloqueo/etiquetado de la OSHA.
4. Abra la puerta del gabinete al que necesita acceder y usando un multímetro verifique que la alimentación esté apagada.

Figure v-2: Bloqueo/Etiquetado del panel de fuente de alimentación



Procedimiento de bloqueo/etiquetado del sistema neumático

Cuando no se requiere bloqueo/etiquetado

Si trabaja con componentes que no son del sistema neumático pero que requieren su presencia en la proximidad de componentes neumáticos móviles, debe, como mínimo, trabar físicamente estos componentes para que no se muevan. Si no es posible, bloquee/etiquete todo el sistema neumático.

Cuando se requiere bloqueo/etiquetado

Antes de intentar reparar o realizar el mantenimiento de una línea o componente neumático, bloquee/etiquete la máquina en forma apropiada. Siga los procedimientos de bloqueo/etiquetado aprobados por la compañía.

Solución de problemas con una máquina energizada

Sólo un electricista calificado que utilice el equipo de protección personal y siga los procedimientos recomendados en la norma NFPA 70E debe intentar realizar tareas de reparación o mantenimiento en un área o componente energizados de la máquina o en su proximidad.

Cada vez que se realizan tareas de mantenimiento mientras el equipo está eléctricamente energizado, existe un riesgo potencial de formación de un arco eléctrico. Consulte en la norma NFPA 70E el equipo de protección personal requerido para trabajar con componentes eléctricamente energizados. Los componentes neumáticos e hidráulicos pueden moverse de manera imprevista si no se desenergizan. Trabe físicamente cualquier componente que pueda moverse cuando deba trabajar en ellos o en su proximidad.

Zonas restringida

	<p>Manténgase alejado de la zona restringida cuando el equipo esté en uso. Pueden producirse lesiones graves o incluso la muerte si el personal está en la zona restringida.</p>

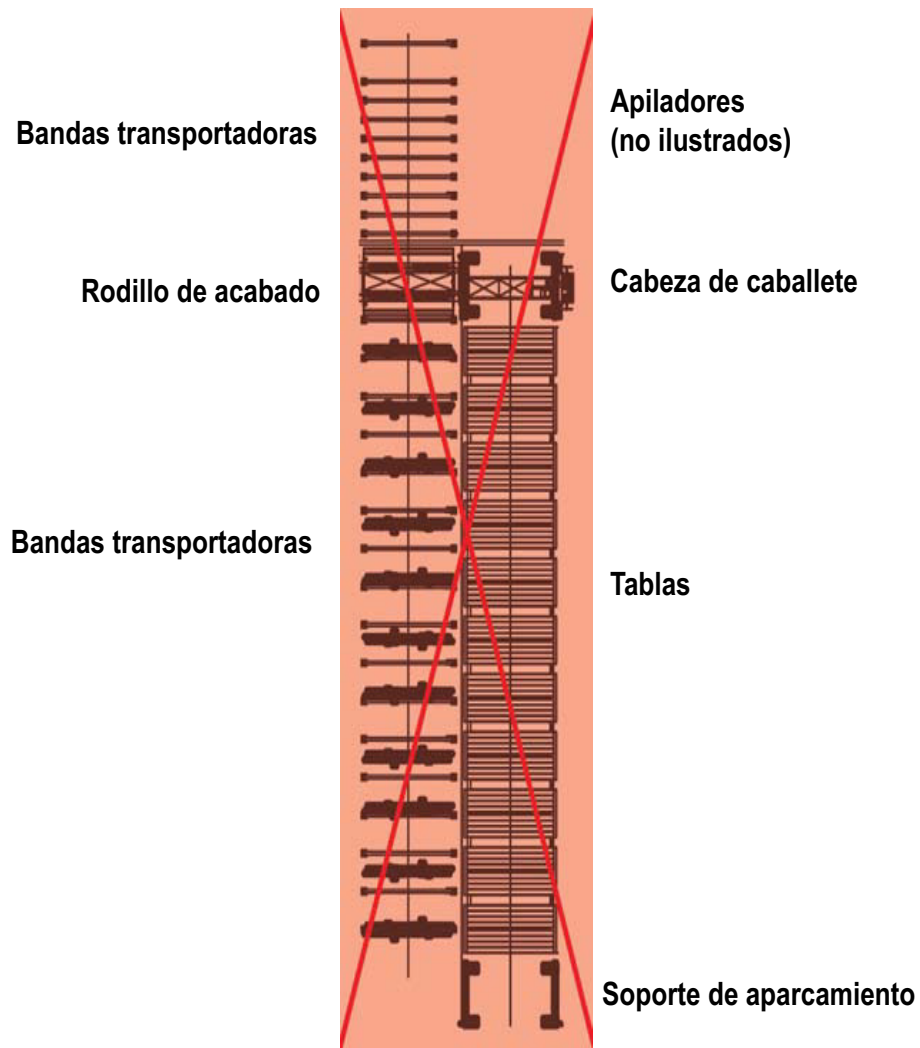

Introduction

Chapter 1

Purpose of Chapter

This chapter explains how to navigate through the equipment manual and how to contact MiTek.

Introduction to the Manual

DANGER	
	<p>Read this manual completely before using this equipment!</p> <p>Do not operate this machine until you have a thorough understanding of all controls, safety devices, emergency stops, and operating procedures outlined in this manual.</p> <p>All warnings must be read and observed. Failure to do so may result in economic loss, property damage, and/or personal injury.</p> <p>This manual must always be available to personnel operating and maintaining this equipment.</p>

Purpose and Scope of This Equipment Manual

In order for this equipment manual to be useful, it must be kept in a location where operators and maintenance personnel have easy access to it.

This manual addresses the most recent versions of the equipment as of the creation or revision date on the title page. For earlier revisions, contact MiTek Machinery Division Customer Service and order the part number listed on the title page.





This manual can also be a valuable training tool.

- The *General Information* chapter contains information on truss terminology and provides basic information about the equipment.
- The *Operation* chapter teaches operators how to efficiently operate the machine.
- The *Maintenance* chapter is written specifically for maintenance personnel.
- The appendices provide valuable technical information to keep your equipment running.

Navigation

The graphics in Table 2-1 are used throughout the manual to quickly communicate a specific type of information.

Table 1-1: Navigational Tools Used Throughout the Manual

Graphic	Explanation
	<p>Important safety note!</p> <p>Indicates that you must lockout/tagout the equipment using approved methods described in OSHA 29 CFR 1910.147 before continuing with the procedure.</p>
	<p>Indicates tools required before beginning a procedure.</p>
	<p>Gives additional information to the steps or text.</p>
	<p>Refers reader to another section, table, graphic, or drawing for further explanation.</p>

Additional Resources

Supplemental Documentation

In addition to the equipment manual, refer to the manufacturer's documentation on the parts that are listed in this section. The supplemental documentation is provided at the time of installation, or it may be found inside an electrical enclosure. Refer to these documents when you need more detailed information on these components than the MiTek manual provides.

Web Site

Visit the MiTek Web site at www.mii.com for up-to-date information on all MiTek equipment. View the latest revision of this manual and all Service Bulletins, or order parts on-line through our eStore.

Contacting MiTek

For technical assistance or to order parts, contact the Machinery Division Customer Service Department using one of the methods listed in Figure 2-1.

Figure 1-1: Contacting MiTek

<p>MiTek Machinery Division Customer Service Department 301 Fountain Lakes Industrial Drive St. Charles, MO 63301</p> <p>Parts Orders (with part number) E-mail: mitekparts@mii.com</p> <p>Technical Assistance Phone: 800-523-3380 Fax: 636-328-9218 machinerysupport@mii.com</p> <p>Web Site www.mitek-us.com</p>	 The MiTek logo, consisting of the letters 'MII' in a bold, black, sans-serif font with three horizontal blue lines through the middle of the 'I's.
---	--

General Information

Chapter 2

Purpose of Chapter

This chapter provides an overview of the equipment and the means to identify it.

Introduction to the Equipment

Purpose of the Equipment

The Roller Gantry is designed for the fast, accurate, and economical production of wood trusses.

Description of the Equipment

The Roller Gantry system fabricates wooden trusses with a two-stage connector plate embedment process. In the first stage, a traveling gantry head (see Figure 1-1) performs the initial plate embedment by partially seating the connector plates into the wood fiber. In the second stage, a finish roller completes the plate embedment process.

The Roller Gantry (see Figure 1-1) is a 24-inch diameter roller press with manual controls. It is equipped with steel wheels that roll along a steel track beside the jig tables.

The Roller Gantry is driven smoothly and effectively along its track by a four-wheel drive system that is powered by an electric motor.

The Electrification System consists of either a “festoon-type” electrical cord or a bus bar. The SO cord is supported by wire rope stretched 12' above the floor with suitable masts, rollers, turnbuckles, etc. The bus bar is supported by brackets hanging from the ceiling (12' above the floor). The bus bar hanger brackets are to be supplied by the customer.

Figure 2-1 shows an overall view of the equipment. Refer to the *Maintenance* chapter for more detailed graphics.

Figure 2-1: Roller Gantry

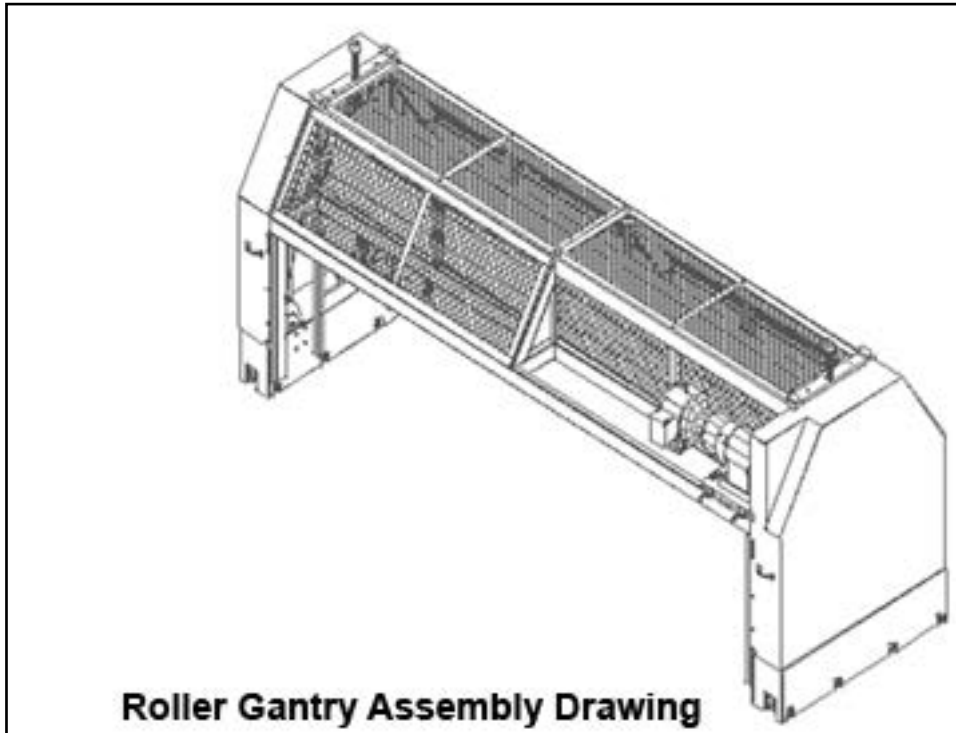

General Specifications

Table 2-1: General Specifications - General, Gearbox

General	
Speed (press capacity)	100' per minute (standard) 150' per minute (optional)
Direction	Forward/reverse
Height adjustment	0" to 6"
Roller diameter	24" nominal (outside)
Roller wall thickness	3/4" nominal
Baffles per roller	4 (completely welded)
Throat opening	14'-4" wide
Shaft diameter	4" outside diameter
Bearing size	3-7/16" heavy duty
Weight	10,000 lb
Gearbox - David Brown Series M Radicon	
Ratio	36:1
Rpm input	1,750
Rpm output	49
Hp maximum	7-1/2
Frame	213TC

Table 2-2: General Specifications - Motor

Motor - Electric	
Horsepower rating	7-12 hp
Motor speed	1,750 rpm
Starting switch	Pushbutton - pendant
Voltage	208/230/460 VAC
Amperage	25.3/22.0/11.0 amps
Cycles	60
Phase	3
Frame	213TC
Clutch	Centrifugal (Soft-Start™)
Brake	Electrical magnetic disk (industrial)
Controls	Pushbutton station (pendant optional)
Wheels	4 drive wheels, 16 bogie wheels
Chain drive	#100 and #80
Dimensions of System Components	
See Table 1-1	
Weight of System Components	
See Table 1-4	

NOTICE

Standard motors are furnished unless otherwise specified by customer. Nonstandard motors are subject to additional cost.

Customers must supply disconnects.

Truss Terminology

Table 2-3: Truss Terminology

Length Types	Height Types	
Overall length	H1	Board height
Centerline length	H2	Centerline height
Top length	H3	Centerline height
Bottom length	H4	Centerline height

Figure 2-2: Terminology Diagram

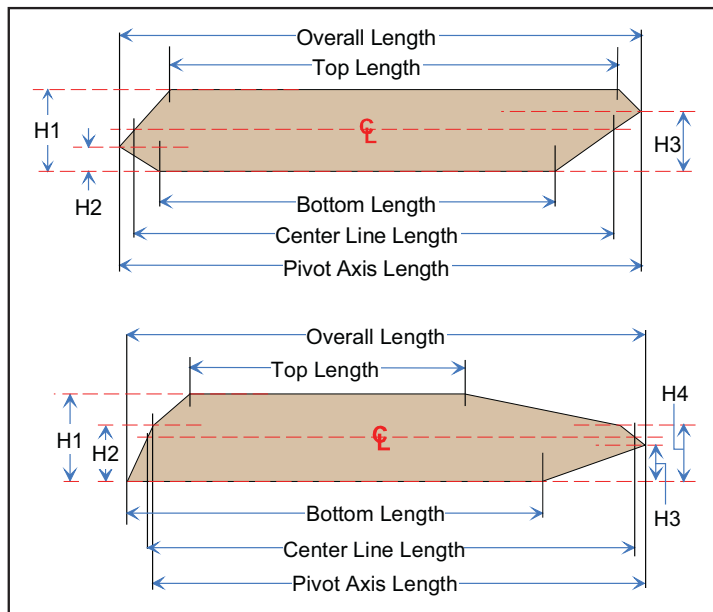
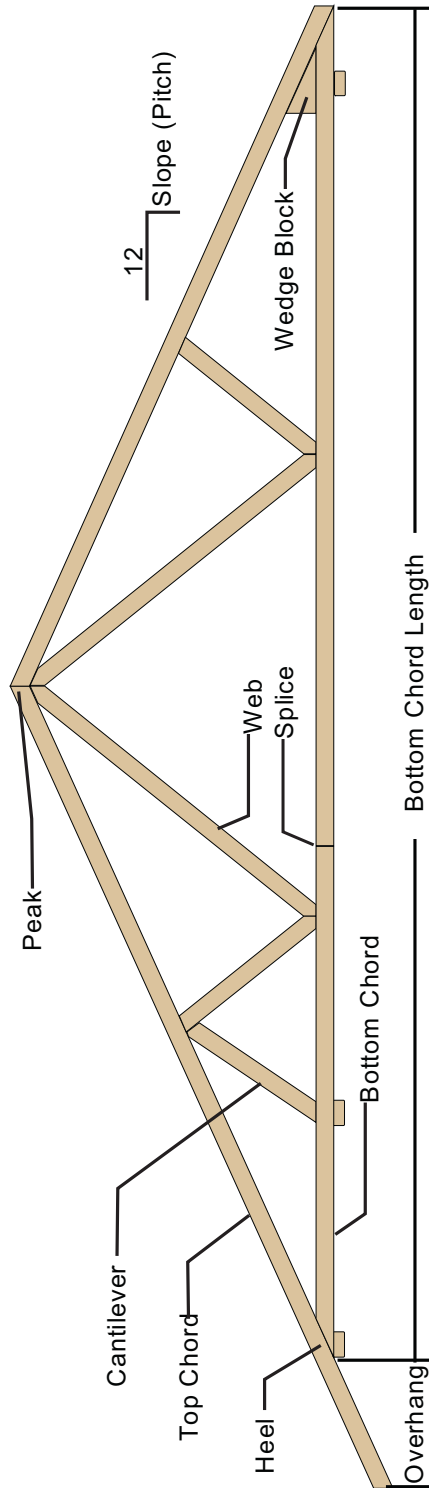

Figure 2-3: Parts of a Truss



Prior to Installation

Chapter 3

Purpose of Chapter

This chapter covers what you must consider or complete before this equipment can be installed.

MiTek's Responsibilities

Prior to Installation

MiTek will provide the following items and information prior to the installation date:

1. A Prior to Installation package that:
 - Outlines this chapter and requests your signature of agreement.
 - Gives dates to expect shipment, delivery, and installation.
 - Explains the number of people required to help with installation.
 - Provides guidelines on providing an electrician, welder, and other specialists.
 - Describes payment information.
2. A layout of the equipment.

During Installation

A MiTek Customer Service Technician (CST) may be present to manage the installation of your equipment.

Customer Responsibilities

Before the installation of your equipment, the items and procedures in this chapter must be arranged, purchased, or assembled. Table 2-1 provides an overview of these items. Each topic listed in the table is explained in detail in the text following the table.

If these requirements are not satisfied before the scheduled installation date, it may be necessary to reschedule the installation. Any additional cost may be the customer's responsibility.

Figure 3-1: Summary of Customer Responsibilities

Space Requirements	This equipment requires enough space to allow for the machine dimensions listed in Table 1-1, plus additional working space for operation and maintenance. Space should have adequate lighting.
Location Requirements	Concrete, a minimum of 6 in. thick 5,000 psi, is required under the weight of the press head, tables, and stand-alone conveyors. The equipment discussed in this manual must be used in dry conditions under a roofed area.
Electrical Requirements	The standard electrical requirements are shown in Table 1-2. Contact your MiTek representative immediately if custom power specifications need to be arranged.
Hydraulic System Requirements	Hydraulic fluid that meets the requirements in Table 1-3 must be on-hand during the installation process.
Pneumatic Requirements (Compressed Air)	See Table 1-3.
Shipping Requirements	See Table 1-3 for shipping weights.
Customer-Supplied Items	The customer is responsible for having the supplies listed in Table 1-4 available at the time of installation.

Location Requirements

Floor Structure

A level and structurally sound concrete slab must be provided for the installation of the equipment. This slab should be designed and installed in accordance with local building code requirements and, if required, under supervision of a professional engineer. Concrete should be a minimum of 6 in. thick. Five thousand (5,000) psi concrete is recommended. Refer to your layout drawing.

Environment

The equipment must be used in dry conditions under a roofed area according to Type 1 electrical enclosure requirements.

Lighting should be adequate for safe operation and maintenance.

Electrical Requirements

WARNING	
	<p>ELECTRICAL HAZARD!</p> <p>All electrical work must be performed by a qualified electrician.</p> <p>Follow approved lockout/tagout procedures (OSHA 29 CFR 1910.147).</p>

The standard electrical requirements are shown in Table 2-1. Each machine can be designed for any of the incoming voltages listed.

The power supply must have a fused disconnect switch, separate from the disconnect switch on the machine. The power supply line must reach the disconnect enclosure on the machine.

You must indicate what voltage is available at the machine’s proposed location when placing the order. This information must be correct. Depending on the voltage available, revisions to the electrical system or a transformer may be necessary.

Table 3-1: Minimum Electrical Requirements for This Equipment

Voltage	208/230/460 VAC
FLA Plus Control Amperage	25.3/22.2/11.1 amps
Equipment Disconnect Protection	35/30/15 amps
Cycles (Frequency)	60 Hz
Phases	3

Training Provided

In the case where MiTek is overseeing the installation of your equipment, the MiTek representative will ensure that your operators and maintenance personnel understand how to operate and maintain this equipment. They will explain warranty information and ensure that the equipment manual is present.

Installation

Chapter 4

Purpose of Chapter

This chapter describes the entire installation process in detail. The instructions assume that the prior-to-installation requirements are satisfied.

Responsibilities During Installation

MiTek can, upon request, provide installation supervision to ensure that the system is installed properly and operates correctly. We will also provide operating and maintenance training at the time the equipment is installed. The customer is responsible for providing all labor and equipment needed to complete the installation. These requirements are explained in the *Prior to Installation* chapter.



All customer responsibilities before and during installation are described in the *Prior to Installation* chapter!

Delivery

Checking for Damage

All shipments from MiTek are covered with tarps. When your shipment arrives, check to ensure that the tarps are in place. Displaced tarps may indicate a potential problem.

After removing the tarps, inspect the shipment for water/moisture, debris, and damage. Report any findings as required by the transport company. Document any findings by taking photographs or a video. Note any and all damage to the equipment on the bill of lading to ensure proper documentation for insurance claims. Without this note, any damage in transit is the responsibility of the customer to repair.

Notify MiTek Machinery Division Customer Service of any unacceptable findings discovered during the receipt inspection. Although your findings may not appear to be a problem, they may cause premature failure of components, poor performance, or erratic performance.

Unloading

Refer to the *Prior to Installation* chapter for information regarding preparing for the delivery.

Even if a MiTek representative is present, it is the customer's responsibility to provide equipment and labor for unloading, placement, and wiring of the equipment.

Exercise extreme caution to avoid damage or misalignment during unloading. Do not apply pressure on any moving parts or fittings. Figure 2-1 shows how to lift and move the equipment safely.

WARNING	
	<p>CRUSH HAZARD.</p> <p>Failure to lift the equipment in the prescribed manner may cause serious injury, including death, or equipment damage.</p> <p>Personnel not involved in the off-loading from the truck shall remain clear of the area.</p> <p>Transport and lifting equipment such as forklifts and cranes must be designed and rated for the load and application.</p>

Figure 4-1: Lift Points



Unpacking

After successful unloading, remove the protective crating material from the pallets. Detach and set aside all loose parts. Move the equipment to the desired location using a forklift or crane appropriate to the weight of each unit. Lift the equipment to remove the pallet, and gently place each unit in its new location.

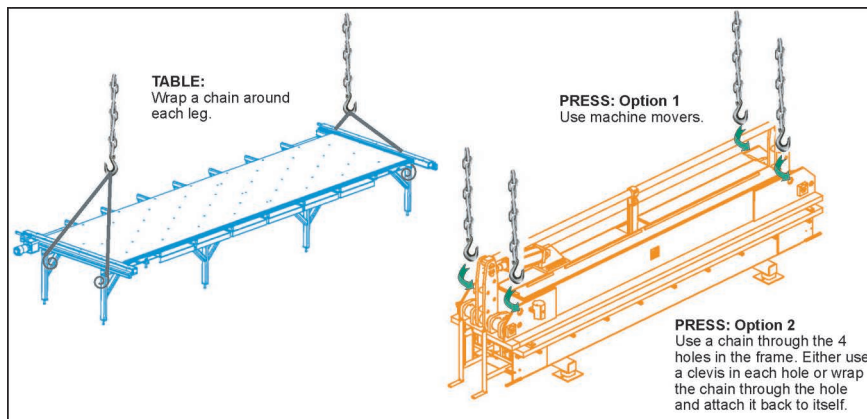
Equipment Layout

Each component must be located in specific locations. Refer to your own layout during installation. Your MiTek representative will provide your layout to you before the equipment is installed.

Assembly

Installation of the complete Roller Gantry can be supervised by a MiTek representative. He can supervise layout, dimensioning, lining, leveling, connecting, assembling, and complete installation of the equipment. He can make pre-operational checks and final adjustments as needed, and instruct personnel in the proper operation and maintenance of the equipment.

MiTek recognizes that the installation can be disruptive to the production schedule. For this reason, we request the most efficient people to assist with the installation. These people can complete their work quickly, efficiently, and with a high degree of quality. The end result is a system that will operate at maximum efficiency.

1. Move the Roller Gantry in place using a forklift and supporting the machine by the frame, NOT THE ROLLER; shim between the 4 x 2 tube frame and the forklift. The machine is heavier on the end with the drive, and the forklift operator must position the forklift to compensate for the offset load. Two forklifts, one at each end of the machine, can be used if a single lift is not large enough.

WARNING	
	<p>CRUSH HAZARD.</p> <p>Do not drop the roller gantry, and do not lift the machine by the rollers.</p> <p>Failure to lift the machine in an approved manner may result in serious injury or death.</p>

2. Place the Roller Gantry on the track, centering the drive wheels. The track must be installed on a 15 ft 10 in. centerline to work with the Roller Gantry.
3. Insert the 16 bogie wheels in the machine. Maintain a 1/16 in. gap between the top of the wheel and the bottom of the rail. Tighten the 1/2 in. bolts to hold the bogie wheels in place. (See Section 5.1-D4 for bogie wheel adjustment instructions.)
4. Wire the Roller Gantry into the building's power system. An electrician must make the connections between the machine and the bus bar/SO cable and the building.

- Adjust the Roller to the desired height for satisfactory plate embedment. Standard embedment is 75% on the top and 50% on the bottom. (See Section 5.1-D5 for detailed Roller setting instructions.)

Forklift

One heavy-duty forklift of not less than 8-ton capacity is required. An operator will be required for unloading and moving the Roller Gantry to the installation site.

If there are any questions, please contact your MiTek Technical Representative (Customer Service).

Electrical System

WARNING	
	<p>ELECTRICAL HAZARD!</p> <p>All electrical work must be performed by a qualified electrician.</p> <p>Follow approved lockout/tagout procedures (OSHA 29 CFR 1910.147).</p>

Checking Existing Wiring

Heavy gauge wire can work loose during shipping and handling. Before power is connected to the machine, conduct a pull test on all pre-wired connections inside the electrical enclosures.

Connecting Power to the Equipment

All electrical work is the customer's responsibility and must be performed by a qualified electrician. The machine design addresses electrical components starting with the disconnect enclosure. Installation and maintenance of all electrical requirements up to the disconnect enclosure are the responsibility of the customer. Your MiTek representative can provide guidance regarding when the electrical will need to be available during the installation.

Installation Checklist

- Check for damage
- Unload machine
- Unpack machine
- Place components in correct location
- Place gantry on track
- Insert bogie wheels
- Connect electrical power to the gantry head
- Adjust the height of the roller

WARNING	
	<p>ELECTROCUTION AND CRUSH HAZARDS!</p> <p>Do not attempt to start the system without a MiTek representative present!</p> <p>Serious injury and/or equipment damage may result.</p>

Operation

Chapter 5

Purpose of Chapter

This chapter describes the operating mechanisms on this equipment and the procedure to operate it in most circumstances.

Safety Hazards During Operation

WARNING	
	<p>ELECTROCUTION, CRUSH, AND CUT HAZARDS!</p> <p>Read this section AND the safety section in the preliminary pages before operating or maintaining this equipment.</p> <p>Do not operate this machine until you have a thorough understanding of all controls, safety devices, E-stops, and operating procedures outlined in this manual.</p> <p>Read and observe all warnings. Failure to do so may result in economic loss, property damage, and/or personal injury.</p> <p>This manual must always be available to personnel operating and maintaining this equipment.</p>

WARNING	
	<p>ELECTRICAL HAZARD!</p> <p>All electrical work must be performed by a qualified electrician.</p> <p>Follow approved lockout/tagout procedures (OSHA 29 CFR 1910.147).</p>

WARNING	
	<p>CRUSH AND CUT HAZARD</p> <p>Guards must always be in place during operation to avoid serious injury and possibly death.</p> <p>Always replace guards after maintenance is complete and before removing the lockout/tagout device.</p>

WARNING	
	<p>CRUSH AND CUT HAZARD.</p> <p>Before turning on the equipment, make sure that all personnel and equipment are clear.</p> <p>Never stand in an aisle while the machine is in operation.</p>

Stopping the Machine

Emergency stops (E-stops) immediately cease power transmitting to the control circuit. Utilize any of the E-stops on this machine to cease transmission of power to the machine, which will stop all motion.

Do not use the E-stops as a standard stopping method during the operation procedure. Overuse may cause certain components to wear faster.

E-Stop Pushbutton.

A typical E-stop pushbutton is shown in Figure 2-1. To activate a pushbutton, push the entire red button in. To release a pushbutton E-stop, pull straight up on the pushbutton. It will return to its extended position and the machine will operate again.

Figure 5-1: E-Stop Pushbutton



Disconnect Switch

The disconnect switch controls the power supplied from that switch to the rest of the machine. Turning the disconnect handle to the ON position supplies electrical power to the entire machine. To remove power to the machine, turn the disconnect handle to the OFF position. The disconnect handle should always be turned off when the machine is not in use.

WARNING	
	<p>ELECTRICAL HAZARD.</p> <p>When the disconnect switch is off, there is still live power to the disconnect switch's enclosure. Always turn off power at the main power source before opening electrical enclosure!</p>

Starting the Machine

Refer to the *Operating Procedure* section on page viii for the operating procedure.

Operator Control Interface

Figure 5-2: Overview of Control Mechanisms

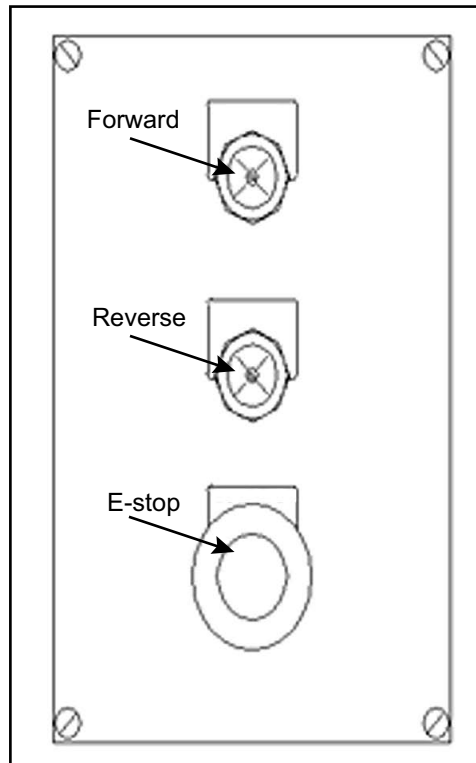



Table 5-1: Functions of Control Mechanisms

Button	Function
FORWARD pushbutton	The machine will run in the forward direction
REVERSE pushbutton	The machine will run in the reverse direction
EMERGENCY STOP button	Stops all motion of the machine

Operating Procedure

WARNING	
	<p>PERSONAL INJURY HAZARD.</p> <p>Before turning on the equipment, make sure that all personnel and equipment are clear.</p>

Safety

See page xiii for safety tests..

WARNING	
	<p>PERSONAL INJURY HAZARD.</p> <p>Never operate the Roller Gantry without all guards in place and operational.</p>

WARNING	
	<p>PERSONAL INJURY HAZARD.</p> <p>Never disconnect or paint over warning note labels. If labels become deteriorated or damaged, request new ones through our Customer Service Department.</p>

Procedure Under Normal Conditions

1. Inspect the area around the Roller Gantry before turning it on.
2. Turn the disconnect handle to the ON (vertical) position.
3. Check the location of both E-stop push bars. They should be in the extended position, making contact with the E-stop limit switches. If they are not, research the cause and correct it before extending the push bars.
4. Press and hold the FORWARD or REVERSE pushbutton to run the Roller Gantry in the required direction.
5. Release the FORWARD or REVERSE pushbutton to stop the Roller Gantry.
6. Standard operating procedure is to press and hold the pushbutton one time per truss. Unnecessarily starting and stopping the Roller Gantry places extra wear and tear on the machine and its components, and should be avoided.

NOTICE

Press the E-stop pushbutton to stop the Roller Gantry in an emergency situation. When an E-stop is pressed, it will stop all motion by removing power to the motor. This is accomplished by disengaging the master control relay.

Maintenance

Chapter 6

Purpose of Chapter

This chapter provides step-by-step instructions as well as information to help you understand how your equipment works to enable you to make repairs and perform preventive maintenance.

Introduction to Maintaining Your Equipment

This manual contains sufficient information for proper maintenance under most conditions. Certain operating environments may necessitate preventive maintenance at more frequent intervals. Because consistent preventive maintenance is so important for keeping mechanical equipment in good operating condition, MiTek recommends that you stock certain replacement parts to minimize downtime.

Review the table of contents and utilize the index to locate the information you need. The following appendices will also assist in maintaining and repairing your equipment:

- Troubleshooting
- Parts List
- Maintenance Checklists
- Drawing Set

Read the *Performing Maintenance Safely* section before beginning maintenance on this equipment.

Performing Maintenance Safely

Read the safety pages in the preliminary pages and adhere to all rules and guidelines. This section provides additional safety information specific to maintenance topics.

Before Operating This Equipment

Adhere to these warnings before operating this equipment:

WARNING	
	<p>ELECTROCUTION, CRUSH, CUT, AND CHEMICAL HAZARDS!</p> <p>Read this section AND the safety section in the preliminary pages before operating or maintaining this equipment.</p> <p>Do not operate this machine until you have a thorough understanding of all controls, safety devices, E-stops, and operating procedures outlined in this manual.</p> <p>Read and observe all warnings. Failure to do so may result in economic loss, property damage, and/or personal injury.</p> <p>This manual must always be available to personnel operating and maintaining this equipment.</p>



Lockout/Tagout

The lock and tag symbol shown here indicates that proper lockout/tagout procedures must be used prior to starting the procedure where the symbol occurs.

WARNING	
	<p>ELECTROCUTION HAZARD.</p> <p>Always turn the power off by activating an E-stop when the equipment is not in operation.</p> <p>Always verify that all power to the machine has been turned off and follow approved lockout/tagout safety procedures (OSHA 29 CFR 1910.147) before performing any maintenance on this equipment.</p> <p>If it is absolutely necessary to troubleshoot an energized machine, follow NFPA 70E for proper procedures and personal protective equipment.</p>

Making Adjustments

Be careful when making mechanical adjustments. Untrained personnel may damage the machine or cause harm to themselves and others.

CAUTION

Failure to follow the step-by-step procedure may result in incorrect adjustment of this machine and could cause damage to the machine. Only trained personnel should make mechanical adjustments to this machine.

Use the exact replacement parts that are specified by MiTek.

Replacing Parts

Special materials have been used for some of the components of this equipment. It is critical to the future performance of this machine that only specified replacement parts are used. Order all replacement parts through MiTek. Do not substitute parts without first consulting MiTek to determine if it is safe and effective. No electrical system component, cable, connector, or device should be modified, removed, disconnected, changed without specific approval and guidance from MiTek.

Wearing Personal Protective Equipment

Follow OSHA guidelines regarding the proper personal protective equipment (PPE) while performing maintenance. The most common guidelines are in regards to eye protection, hearing protection, dust masks while blowing off sawdust, gloves while working with solvents, and fire-retardant clothing when troubleshooting an energized machine.

Conducting Safety Tests

Ensure safety devices are always operating properly.

WARNING



CRUSH HAZARD.

Ensure that all E-stops are operating properly before operating the equipment at the initial startup, after performing any maintenance, and in accordance with the maintenance schedule.

Overview Graphics

Figure 2-1 provides an important overview of the equipment to help you better understand the procedures in the *Maintenance* chapter.

Figure 6-1: Grease Points

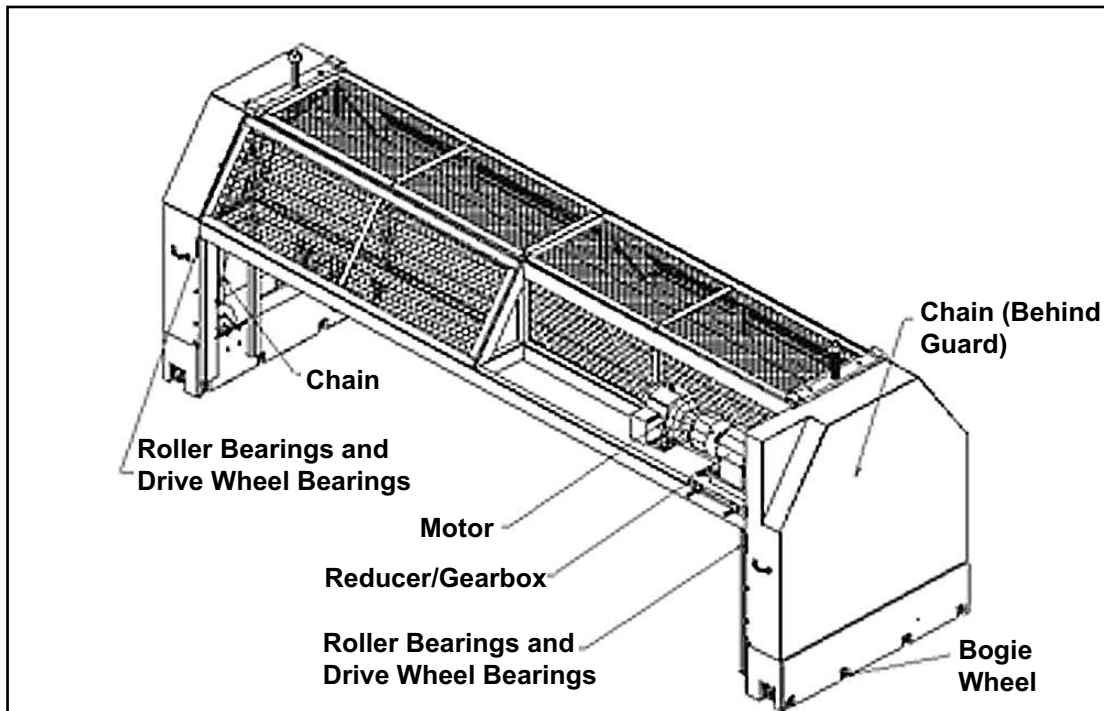

WARNING	
	<p>CRUSH AND CUT HAZARD.</p> <p>Before turning on the equipment, make sure that all personnel and equipment are clear.</p>

Adjustments

WARNING	
	<p>PERSONAL INJURY HAZARD.</p> <p>To prevent unexpected machine operation or possible electrocution, always turn off and lockout the power source before making any machine adjustments or repairs</p>



Adjusting the Speed Reducer/Gearbox Chain

1. Check the #100 drive chain tension. Drive chain play should be 1/2 inch (1/4-inch movement to both sides of the center).
2. Check the drive sprocket alignment; the sprockets should be in the same plane. If they are not, see the *Aligning/Adjusting the Sprocket* section on page x.
3. If gearbox chain tension is required:
 - a) Loosen the reducer/gearbox mounting plate bolts (4) and the motor mounting plate bolts (4).
 - b) Tighten the adjustment bolts (jack screws) on the reducer mounting plate to slide the entire drive assembly outwards until the drive chain play is 1/2 inch (1/4 movement to both sides of center). **IT IS CRITICAL TO KEEP THE DRIVE CENTERLINE PARALLEL WITH THE ROLLER CENTERLINE.**
 - c) Tighten the reducer/gearbox and the motor mounting plate bolts.



Adjusting the Drive Wheel Chain

1. Check the #80 drive wheel chain tension. Drive chain play should be 1/2 inch (1/4 movement to both sides of center).
2. If drive wheel chain adjustment is required:
 - a) Remove the end guards from the Roller Gantry.
 - b) Loosen the mounting bolts on the idler sprocket.
 - c) Tighten the take-up mechanism to slide the idler sprocket upwards to obtain drive chain play of less than 1/2 inch (1/4 movement to both sides of center).
 - d) Tighten the mounting bolts on the idler sprocket.

- e) Check the drive wheel chain adjustment on the other end of the Roller Gantry. Repeat steps a through d if required.



Aligning/Adjusting the Sprocket

Drive Wheel Sprocket and #80 Chain Take-up Sprocket

Both are pre-set at the factory and should not require adjusting. If something is wrong, please consult a Technical Representative in Customer Service at MiTek.

#80 Sprocket on the Roller

This sprocket must be in the same plane as the drive wheel sprockets. The sprocket is a special bored to size unit with two set screws holding it in place on the Roller shaft. Loosen the set screws and move the sprocket as required. Use a straight edge (level, steel bar) to define the correct location.

#100 Sprocket on the Roller

This sprocket must be in the same plane as the drive sprocket on the gearbox. The location of these two sprockets is dependent on the #80 sprocket on the Roller. The #100 sprocket on the Roller will be very close to the #80 sprocket (they can touch hub to hub). Locate the #100 sprocket on the roller and tighten its two set screws.

#100 Sprocket on the Reducer/Gearbox

Use a straight edge to align the two sprockets. If the QD bushing/drive sprocket (on the gearbox) requires moving:



Adjusting the QD Sprocket

1. Remove all cap screws.
2. Install the cap screws into the threaded jack holes.
3. **Tighten all jack screws alternately and evenly, beginning with the screw farthest from the bushing saw slot, until the bushing grip is released.** Slide the unit off the shaft.

CAUTION

Excessive screw torque may cause damage to bushing and/or product. Uneven pressure on the jack screws may also damage the bushing flange, making removal difficult without damage to the product.

4. Clean the shaft, product bore, bushing tapered surface, and bushing bore of oil, paint dirt, etc.

CAUTION

DO NOT USE LUBRICANTS. The use of lubricants can cause damage to the product.

5. QD bushing sizes JA through S (see Table 2-1 on page xii) may be assembled in either conventional or reverse mounting
 - *Conventional Mounting.* Place the bushing in the hub. Tighten the cap screws finger tight into the threaded holes in the bushing flange.
 - *Reverse Mounting:* Place the bushing in the hub and insert the cap screws through the drilled holes in the bushing flange. Tighten the cap screws finger tight into the threaded holes in the hub.

CAUTION

When mounting a product on size M through S bushings, position the hub jack holes away from the bushing saw slot to reduce the possibility of bushing breakage, and insert the cap screws through the drilled holes in the hub.

6. With the key on the shaft, slide the loosely assembled unit onto the shaft so that the cap screw heads are on the outside. Locate the unit in the desired position on the shaft.



When installing large or heavy parts in the conventional position, it may be easier to mount the key and bushing on the shaft first, then place the sprocket on the bushing aligning the holes and installing the cap screws.

7. Tighten the cap screws alternately and evenly to the wrench torque specified in Table 2-1).



When tightened, there will be a 1/8 in. to 1/4 in. gap between the bushing flange and the hub. Should this gap close, then either undersize shafting or wrong bushing shaft size is indicated.

CAUTION

Excessive screw torque may cause damage to the bushing and/or the product.

8. Tighten the set screw over the key to the torque value listed in Table 2-1.

Table 6-1: Recommended Torque Values

Bush-ing	Recommended Torque				Bush-ing	Recommended Torque			
	Cap Screws		K. S. Set Screw			Cap Screws		K. S. Set Screw	
	Size	lb-in	Size	lb-in		Size	lb-in	Size	lb-in
H	1/4-20x7/8	90	—	—	F	9/16-12x3-5/8	900	3/8-16	290
JA	#10-24x1	60	—	—	J	5/8-11x4-1/2	1620	1/2-13	620
SH	1/4-20x1-3/8	108	1/4-20	87	M	3/4-10x6-3/4	2700	1/2-13	620
SDS	1/4-20x1-3/8	108	1/4-20	87	N	7/8-9x8	3600	5/8-11	1325
SD	1/4-20x1-7/8	108	1/4-20	87	P	1-8x9-1/2	5400	5/8-11	1325
SK	5/16-18x2	180	1/4-20	87	W	1-1/8-7x11	7200	3/4-10	2400
SF	3/8-16x2	360	3/8-16	290	S	1-1/4-7x15	9000	1-8	7200
E	1/2-13x2-3/4	720	3/8-16	290					

Table 6-2: Bag of Hardware

Bag of Hardware			
Bushing	Part Number	Bushing	Part Number
H	411682	E	411688
JA	411683	F	411689
SH	411684	J	411690
SDS	411684	M	411691
SD	411685	N	411692
SK	411686	P	411693
SF	411687		



Adjusting the Bogie Wheels

1. Check the bogie wheels (16) for 1/16 inch clearance between the top of bogie wheel and the underside of the rail head.
2. If bogie wheel adjustment is required:
 - a) Loosen the bogie wheel axle mounting bolts.
 - b) Slide the axle back and forth to obtain clearance.
 - c) Tighten the bogie wheel axle mounting bolts.
 - d) Repeat the bogie wheel clearance check.



Adjusting the Roller Gantry Roller Setting

1. Check the Roller setting with standard 2 in. x 4 in. (1-1/2 in. thick) lumber and 1/16 in. shim. The shim should slide between the bottom of the Roller and the 1-1/2 in. thickness of the 2 x 4 at each end of the Roller. If satisfactory plate embedment (75% into the top and 50% into the bottom of the truss) is not present, repeat with only the 2 x 4 lumber.
1. If the Roller setting requires adjustment:
 - a) Using a hammer and a wooden block, drive the hanger bearing threaded rod away from the L bracket.
 - b) Loosen the 1-3/4 in. nut above the L bracket 1 turn.
 - c) Loosen the 1-3/4 in. lock nut located below the L bracket hanger bracket by hand.
 - d) Tighten or loosen the 1-3/4 in. nut above the L bracket to set the Roller height.
 - e) Obtain the desired Roller height/clearance (see step1).
 - f) Hand tighten the 1-3/4 in. nut below the L bracket against the L bracket.
 - g) Tighten the top 1-3/4 in. nut against the L bracket.
 - h) Using the hammer and wooden block, drive the hanger bracket threaded rod back towards the L-bracket to lock the bottom 1-3/4 in. nut in place.
 - i) Check the Roller setting adjustment on the other side of the Roller Gantry. Repeat step 2 if required.

Checking Operation of the Roller Gantry

WARNING	
	<p>PERSONAL INJURY HAZARD.</p> <p>Do not operate the Roller Gantry unless all roller and drive chain guards are in place.</p> <p>Be sure all electrical box covers are in place.</p> <p>Periodically check the operator push bars to be sure they are operating correctly.</p> <p>Observe that the track and tables are clear of obstructions and persons before movement of the Roller Gantry.</p>

1. Visually check the Roller Gantry during operation to see how it runs on the rails. If it moves faster on one rail than the other, or moves sideways on rails:
 - a) Check the drive wheel chain tension adjustment on both sides of the machine for equal tightness.
 - b) Check the bogie wheel clearance of 1/16 in. between the top of the wheel and the bottom of the rail.

Table 6-3: Roller Gantry Lubrication Chart

Areas to Be Lubricated	Lubricant	Mfg.'s No. & Grade	Hours of Operation					
			8	16	40	200	500	1,000
Reducer/gearbox - Drain fluid and refill after first 150 hrs of service and every six (6) months thereafter. Suggested times: spring and fall—time to change seasonal oil viscosity (light for winters, heavy for summer).	Use oil recommended by manufacturer of speed reducer/gearbox					X		
Electric Motor	See Note	Impact grease*	See Note				X	
Drive wheel bearing with zerk (4 each)	No. 2 lithium-based grease				X			
Roller bearing with zerk (2 each)	No. 2 lithium-based grease				X			
Bogie wheels bearing (16 each)	No. 2 lithium-based grease			X				
Chain	Oil	Chain Lube	X					

Note: The motor is equipped with double-shield ball bearings with sufficient grease to last indefinitely. Where the motor is used regularly in dirty, wet, or corrosive atmosphere, it is advisable to add 1/4 ounce of grease per bearing every 1,000 hours of operation—Chevron SRI or equivalent.

CAUTION

Upon delivery of the machine, do not start without checking oil level in the gearbox.

Failure to maintain the proper oil level may result in damage to the machine.

CAUTION

Injection of excess grease under pressure into sealed bearings may rupture seals.



Movement of grease through bearings can be checked visually by the appearance of grease at the ends of the bearings.

Old grease should be forced out with shot of new grease. When greasing bearing, wipe the fittings clean.

More bearing failures are caused by dirt introduced during greasing than from insufficient grease.

Figure 6-2: Roller Gantry Lubrication

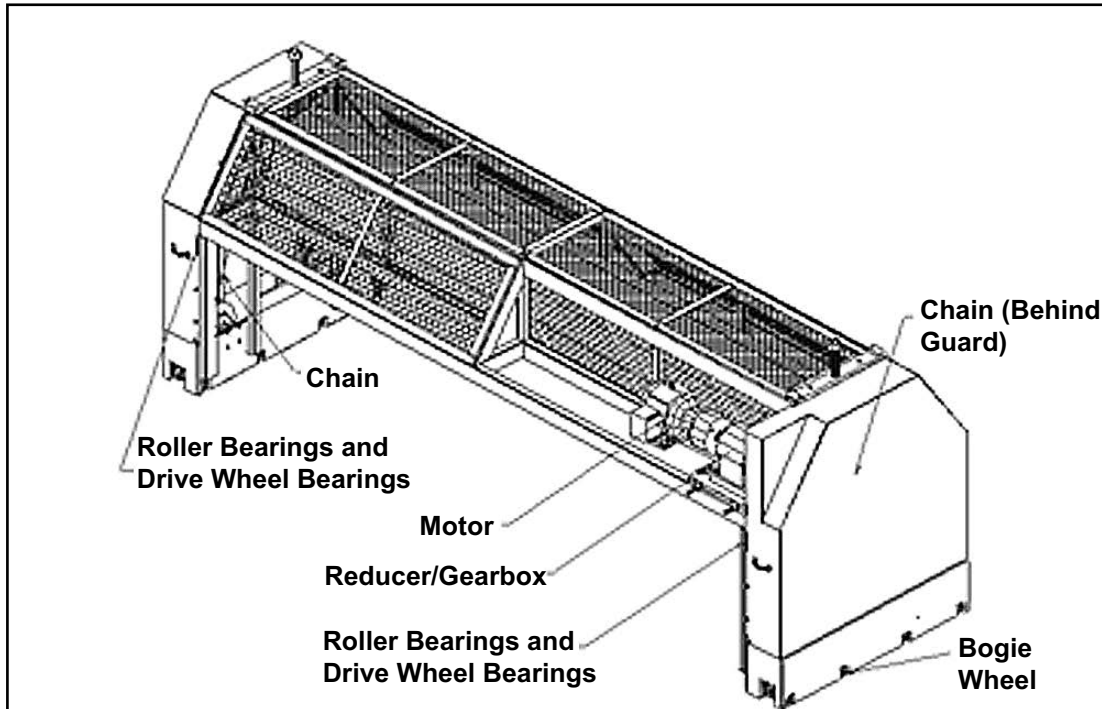

Cleaning, Lubricating, and Inspecting

Cleaning

WARNING	
	<p>CRUSH AND CUT HAZARD</p> <p>Guards must always be in place during operation to avoid serious injury and possibly death.</p> <p>Always replace guards after maintenance is complete and before removing the lockout/tagout device.</p>

CAUTION
<p>Do not use compressed air inside the electrical enclosures! It may force contaminants into the electrical connections.</p>

Figure 6-3: Never Use Compressed Air Inside an Electrical Enclosure





Lubricating

Proper amounts of motor oil and grease must be maintained at all times. The type of lubrication used, frequency of application, oxidation, and contamination of the lubricant affect service life and parts efficiency of gears and bearings. Improved performance will be obtained by following the guidelines in this manual. Lubrication guidelines are given in this chapter for each part or system that requires lubrication. The information is also in the *Maintenance Checklist* appendix.

CAUTION

Never mix synthetic lubricants with mineral lubricants!

Motors and Gearboxes

Certain preventive maintenance is required to keep the motor and gearbox in optimal working order. Table 2-4, Table 2-5 and Figure 2-4 list recommended lubricants for the speed reducer/gearbox.

Table 6-4: Recommended Lubricants - Mineral Oils

Lubricant Supplier	Lubricant Range Name	ISO Viscosity/DBR Grade No./AGMA No.		
Mineral Oils		220/5E/5EP	320/6E/6EP	460/7E/7EP
		Ambient Temperature Range °C		
		-5 to 25 (23 to 77°F)	0 to 40 (32 to 104°F)	10 to 50 (50 to 122°F)
		Chevron Oil Co.	Chevron Gear Compounds EP	220
Esso Petroleum Co.	Spartan EP	220	320	460
Mobil Oil Co.	Mobil Gear 600 Series	630	632	634
Shell Ltd.	Omala	220	320	460
Tribol	Molub Alloy Gear Oil	90	690	140
	Tribol 1100	220	320	460

Table 6-5: Recommended Lubricants - Synthetic Oils

Lubricant Supplier	Lubricant Range Name	ISO Viscosity/DBR Grade No./AGMA No.		
Synthetic Oils		220/5H/55	320/6H/65	460/7H/75
		Ambient Temperature Range °C		
		-10 to 30 (14 to 86°F)	0 to 45 (32 to 133°F)	10 to 50 (50 to 122°F)
		Chevron Oil Co.	Synthetic DBH	220
Esso Petroleum Co.	Spartan SEP	220	320	460
Mobil Oil Co. Ltd.	Mobil Gear SHC	220	320	460
Shell Ltd.	Hyperia S	220	—	460
Tribol	Tribol 1510	220	320	460



Electric Motor and Soft-Start™ Clutch

WARNING	
	<p>PERSONAL INJURY HAZARD.</p> <p>To prevent unexpected machine operation or possible electrocution, always turn off and lockout power source before making any machine adjustments or repairs.</p>

Periodically inspect your electric motor for excessive dirt, friction or vibration. Dust may be blown from inaccessible locations using compressed air. Keep the ventilator openings clear to allow free flow of air.

WARNING	
	<p>PERSONAL INJURY HAZARD.</p> <p>To avoid eye injuries, always wear safety glasses when using compressed air.</p>



Cleaning, Inspecting, and Replacing the Soft-Start Clutch Pad

Removing the Soft-Start Clutch Pad

1. Turn off all electricity to the Roller Gantry.
2. Remove the four bolts and four lock washers from the screen of the clutch assembly.
3. Remove the four bolts and four lock washers from the flange of the motor and clutch.
4. Remove the four nuts, four lock washers, eight washers, and four bolts from the motor and mount.
5. Carefully slide the motor back from the clutch to expose the self-adhesive clutch lining/pad.

CAUTION	
	<p>PERSONAL INJURY HAZARD.</p> <p>The 7-1/3 hp motor weighs approx. 90 lb. Use appropriate number of personnel and proper lifting techniques.</p> <p>Failure to exercise caution may result in personal injury.</p>

6. Remove the old lining and clean off the weight block.

Installing the New Clutch Linings/Pads

1. Remove the backing on the new linings and place them in position.



The adhesive on the back of linings will hold the lining in position during assembly of parts and will prevent the lining from dragging on the rim.

2. Carefully slide the motor back to the clutch.
3. Install the four nuts, four lock washers, eight washers, and four bolts on the motor and mount.
4. Install the four bolts and four lock washers on the flange of the motor and clutch.
1. Install the four bolts and four washers on the screen of the clutch assembly.



Replacing the Motor

Removing the Motor

1. Turn off all electricity to the Roller Gantry.
2. Remove the drive guard.
3. Disconnect the electric wires from the motor to the brake and the motor to the control panel.
4. Remove the four bolts and four washers from the flange of the motor and clutch.
5. Remove the four nuts, four lock washers, eight washers, and four bolts from the motor and mount.
6. Carefully slide the motor back from the clutch to expose the clutch drive.

CAUTION	
	<p>PERSONAL INJURY HAZARD.</p> <p>The 7-1/3 hp motor weighs approx. 90 lb. Use appropriate number of personnel and proper lifting techniques.</p> <p>Failure to exercise caution may result in personal injury.</p>

7. Remove the motor from the mounting plate and clutch drive.
8. Remove the clutch drive hub from the motor.

Installing the Motor

1. Install the clutch drive hub on the new motor and position the motor on the mounting plate.
2. Carefully slide the motor back to the clutch and align.
3. Install the four nuts, four lock washers, eight washers, and four bolts to the motor and mount.
4. Install the four bolts and four lock washers to the flange of the motor and clutch.
5. Connect the wires to the motor and brake.
6. After checking that the key is secure, operate the motor free of load, and check the direction of rotation. If the motor rotates in the wrong direction, interchange any two line leads. Couple the motor to its load.
7. Replace the guard.
8. Operate for a minimum of one hour. During this period, check for any unusual noise and thermal conditions. Check the actual operating current to be sure that the name plate current times service factor is not exceeded for steady continuous loads.

Brake

Inspecting the Brake

1. Inspect the brake disc every 3,000 cycles or six months, whichever comes first. The disc should be replaced when worn to .475 in. thickness.
2. Inspect the disc for general condition and signs of unusual wear. Remove any buildup of wear particles.
3. Inspect the bolts, hub set screws, etc. for tightness.

WARNING	
	<p>CRUSH HAZARD.</p> <p>Brake failure may be caused by improper application, voltage fluctuations, and/or lack of maintenance.</p> <p>Failure to properly maintain the brakes may cause machine malfunction, which can result in serious injury or death.</p>

CAUTION

Do not energize the brake with the cover assembly or armature assembly removed. Damage to the machine will result.



Replacing the Magnetic Disc Brake Lining

Removing the Lining

1. Turn off all electricity to the Roller Gantry.
2. Disconnect the electric wires from the motor to the brake and the motor to the control panel.
3. Remove the four bolts and four washers from the screen of the clutch assembly.
4. Remove the four bolts and four lock washers from the flange of the motor and clutch.
5. Remove the four nuts, four lock washers, eight washers, and four bolts from the motor and mount.
6. Disconnect the motor and brake leads.
7. Carefully slide the motor back from the clutch to expose the clutch drive, and remove the assembly from the machine.

CAUTION



PERSONAL INJURY HAZARD.

The 7-1/3 hp motor weighs approx. 90 lb. Use appropriate number of personnel and proper lifting techniques.

Failure to exercise caution may result in personal injury.

8. Remove the clutch from the brake.
 - a) Remove the four bolts from the flange of the clutch and the brake.
 - b) Carefully slide the clutch back from the brake.
9. Remove the four bolts and four lock washers from the reducer/gearbox and brake.
10. Remove the two set screws from the brake housing.

11. Remove the brake winding assembly from the housing assembly.
 - a) Remove the three cap screws and the winding assembly cover from the brake housing.
 - b) Remove the winding assembly from the brake housing, pulling the brake leads through the conduit.
12. Remove the brake housing assembly from the reducer/gearbox.
 - a) Release the two manual release levers on the brake to free the brake disc.
 - b) Loosen the two mounting bolts with an Allen wrench.
 - c) Remove the set screw, splined hub, and key from the shaft.
13. Remove the brake lining from the housing assembly.
 - a) Press in and turn the compression ring to release the compression ring, springs, armature, and brake disc.
 - b) Clean and inspect the disc for .475 in. thickness.

Installing the New Lining

1. Install the new brake disc, armature, springs, and compression ring.
2. Press in and turn the compression ring to lock.
3. Install the splined hub on the shaft.
 - a) Install the key, splined hub, and set screw on the shaft.
 - b) Tighten the set screw on the key, splined hub, and shaft.
4. Install the brake winding assembly on the housing assembly.
 - a) Install the winding assembly on the brake housing, threading the brake leads through the conduit.
 - b) Install the three cap screws and the winding assembly cover on the winding assembly and brake housing.
5. Install the brake housing assembly on the reducer/gearbox.
 - a) Release the two manual release levers on the brake to free the brake disc.
 - b) Loosen the two mounting bolts with an Allen wrench.
6. Install the clutch on the brake.

- a) Carefully slide the motor and the clutch back to the brake.
- b) Install the four nuts, four lock washers, eight washers, and four bolts to the motor and mount.
- c) Install the four bolts and four lock washers to the flange of the brake and clutch.
- d) Install the four bolts and four washers to the screen of the clutch assembly.

Parts List

Appendix A

Safety Notes for Replacing Parts

CAUTION

Only use the exact replacement parts that are specified by MiTek. Substitutions may harm your equipment.

WARNING



CRUSH HAZARD.

Test all E-stops for proper operation before operating the equipment at the initial startup, after performing any maintenance, and in accordance with the maintenance schedule.

WARNING



ELECTRICAL HAZARD!

All electrical work must be performed by a qualified electrician.

Follow approved lockout/tagout procedures (OSHA 29 CFR 1910.147).

WARNING



ELECTROCUTION HAZARD.

Always turn the power off by activating an E-stop when the equipment is not in operation.

Always verify that all power to the machine has been turned off and follow approved lockout/tagout safety procedures (OSHA 29 CFR 1910.147) before performing any maintenance on this equipment.

Part Numbers

Table A-1: Replacement Parts

Item	Qty.	MiTek Part #	Part Description
1	8	415492	1-1/2" Unisphere flange bearing
2	4	68175	Drive wheel assembly - 12C diameter
3	4	68177	Drive wheel - 12" diameter
4	4	68176	Drive wheel axle
5	4	68179	Drive wheel key
6	4	68178	Drive wheel sprocket key
7	16	68027	Bogie wheel
8	8	68031	Bogie axle - long
9	8	68026	Bogie axle - short
10	8	68030	Bogie wheel assembly - long axle
11	8	68025	Bogie wheel assembly - short axle
12	16	415493	Bogie wheel bearing
13	16	68028	UHMW bogie wheel washer
14	16	68029	Steel bogie wheel washer
15	1	542016	Soft-Start™ clutch (complete unit)
16	1	542503	Clutch lining/pad set
17	1	542505	Clutch drive hub (holds the G54 mechanism)
18	1	542507	Clutch drive hub cap
19	1	542506	Clutch driven hub
20	1	542502	G54 Mechanism (clutch weights and pad)
21	1	542504	Clutch spring
22	1	542508	Clutch safety cover
23	1	491049	Gearbox
24	1	471260	7-1/2 hp motor
25	1	554008	#80 Roller chain
26	1	554009	#100 Roller chain
27	1	480287	Brake
28	1	485001	Brake lining
29	1	535095	Sprocket - #100 SF16
30	1	547095	QD Bushing SF x 2-1/8
31	1	535095	Sprocket - #100 B45 - special
32	2	551307	Sprocket - #80 B48 - special
33	2	558131	Idler Sprocket - #80 BB12
34	4	551308	Sprocket - #80 B23
35	2	532011	Take-up bearing - 3-7/16"
36	1	66115	24" Diameter x 14' Roller

Technical Information

Appendix B

This appendix provides general information that will help you better understand how this equipment works.

Understanding Overloads

Purpose and Scope

The information below has been collected to help you understand the role of an overload, how an overload works, and how to calculate the overload setting to protect the motor.

The Importance of Protecting Your Motor

The following statement describes the importance of protecting electric motors and is a good illustration of why we need overloads.

Proper Motor Protection Safeguards Your Investments

With electric motors driving the majority of today's manufacturing processes, proper motor protection is critical. Not surprisingly, a significant amount of effort and resources have recently been invested in motor protection technology, resulting in cost-effective solutions to many of today's common motor problems.

Motors fail for a number of reasons—moisture and contamination, short circuits, mechanical problems and old age—but the primary reason is excessive heat, caused by excess current (greater than normal motor full load current), high ambient temperatures, and poor ventilation of the motor. If a motor is continuously overheated by only 10 degrees, its life can be reduced by as much as 50%.

Steve Zimmerman
Control Engineering
December 1, 1997

What is an Overload?

So, what is an overload? The term literally means that too much load (what the motor is driving) has been placed on the motor. A motor is designed to run at a certain speed, called its synchronous speed. If the load on the motor increases, the motor draws more current to continue running at its synchronous speed.

It is quite possible to put so much load on a motor that it will draw more and more current without being able to reach synchronous speed. If this happens for a long enough period of time, the motor can melt its insulation and burn out, resulting in damage to the motor windings. This excessive load condition is called an overload.

In fact, the motor could stop turning altogether (called a locked rotor) under a large enough load. This is another example of an overload condition. Even though the motor shaft is unable to turn, the motor continues to draw current, attempting to reach its synchronous speed.

Although the running motor may not draw enough current to blow the fuses or trip circuit breakers, it can produce sufficient heat to burn up the motor. This heat, generated by excessive current in the windings, causes the insulation to fail and the motor to burn out. We use the term “locked rotor amps” to describe when the motor is in this state and is drawing the maximum amount of current.

Due to the possibility of excessive current draw, an overload protection device is required that does not open the circuit while the motor is starting, but opens the circuit if the motor gets overloaded.

Starting Current

When a motor is started, it must perform work to overcome the inertia of the rotating portion of the motor and the attached load. The starting current measured on the incoming line is typically 600% of full-load current when rated voltage and frequency is first applied to a NEMA B motor. The stationary portion of the motor current decreases to its rated value as the rotor comes up to speed.

Figure B-1: Motor Inrush Curve

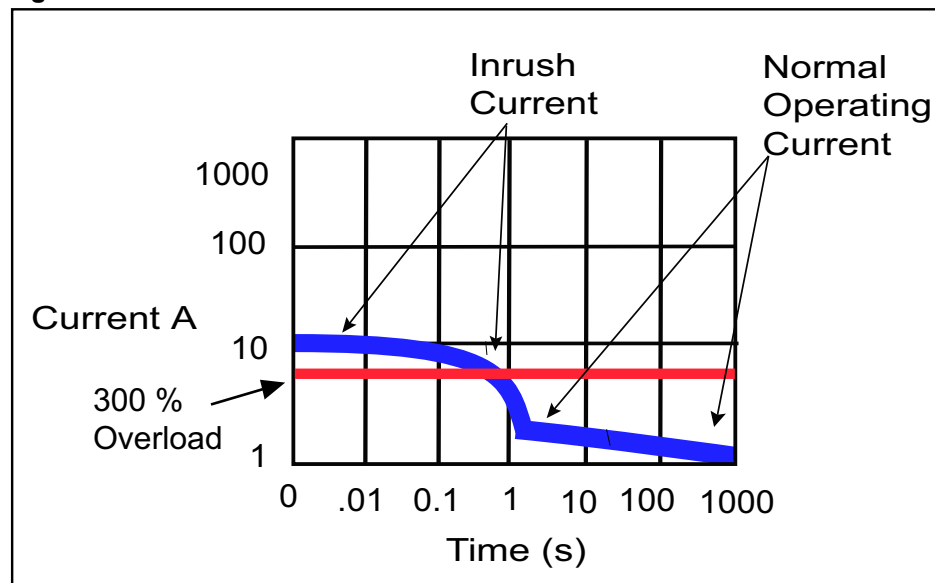

An overload condition will occur when the rotor has difficulty turning and draws more current than it normally would need to keep it turning. When an overload occurs the current being drawn is usually between 2 to 6 times the normal operating current.

For example if a conveyor belt becomes jammed and does not allow the rotor to turn, the motor will draw about as much amperage as it would on startup to try to get the rotor to turn. As long as the rotor does not turn, this increased current will continue to flow. The key thing to remember in an overload condition is that the current flows through the normal circuit path. Continued overload current will cause excess heating in the motor and the motor circuit. If the over current protective device does not operate in a timely manner, the motor could short out a winding, or cause insulation damage to a winding which could lead to a short circuit later.

Overload Relays

The overload relay is the device used in starters for motor overload protection. It limits the amount of current drawn to protect the motor from overheating.

An overload relay consists of:

- A current sensing unit (connected in the circuit to the motor)
- A mechanism to break the circuit, either directly or indirectly

Overload relays have the following features:

- A time delay which ignores harmless temporary overloads caused by normal motor starting, without breaking the circuit
- A means of resetting the circuit once the overload is removed

- A design that meets the special protective needs of motor control circuits
- Allow harmless temporary overloads, such as motor starting, without disrupting the circuit
- Will trip and open a circuit if current is high enough to cause motor damage over a period of time
- Can be reset once the overload is removed

Bimetallic Overload Relays

Overload protection is accomplished with the use of a bimetallic strip. This component consists of a small heater element wired in series with the motor and a bimetallic strip that can be used as a trip lever. A bimetallic strip is made of two dissimilar metals bonded together. The two metals have different thermal expansion characteristics, so the bimetallic bends at a given rate when heated.

Under normal operating conditions the heat generated by the heater element will be insufficient to cause the bimetallic strip to bend enough to trip the overload relay.

As current rises, heat also rises. The hotter the bimetallic becomes, the more it bends. In an overload condition the heat generated from the heater will cause the bimetallic strip to bend until the mechanism is tripped, stopping the motor.

If heat begins to rise, the strip bends, and the spring pulls the contacts apart, breaking the circuit, as shown in Figure 2-2.

Figure B-2: The Warping Effect of the Bimetallic Strip

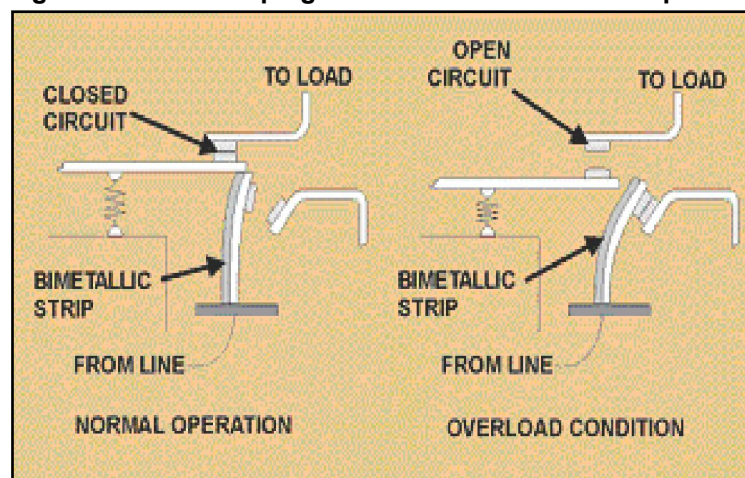

Once the tripping action has taken place, the bimetallic strip cools and reshapes itself, automatically resetting the circuit. The motor can be restarted even when the overload condition has not been cleared, and will trip and reset itself again and again. (This assumes an automatic reset and can also be equipped with a manual reset.)

Electronic Overload Relay

Electronic overload relays are another option for motor protection. The features and benefits of electronic overload relays vary but there are a few common traits. One advantage offered by electronic overload relays is heater-less design. This reduces installation cost and the need to stock a variety of heaters to match motor ratings. Electronic overload relays can detect a phase loss and disconnect the motor from the power source. This feature is not available on mechanical types of overload relays.

Overload Classifications

Overload relays also have an assigned trip class. The trip class is the maximum time in seconds at which the overload relay will trip when the carrying current is at 600% of its current rating. Bimetallic overload relays can be rated as Class 10, meaning that they can be counted on to break the circuit no more than ten seconds after a locked rotor condition begins. Melting alloy overload relays are generally *Class 20*.

American industry has standardized on Class 20 overload protection. The Europeans have standardized on Class 10.

Class 20 will give a nominal 590-second trip (9.83 minutes) at an overload of 125% of full load amps, a 29-second trip at a 500% overload, and a 20-second trip at a 600% overload. Thus, a motor that is stalled and drawing locked rotor amperage will be taken off-line in 20 to 29 seconds. However, a motor that draws a continuous locked rotor current can be expected to burn out before 20 seconds.

Class 10 will give a nominal 230-second trip (3.83 minutes) at 125% overload, 15 seconds at 500% overload, and 10 seconds at 600% overload.

Class 30 has a longer time delay to be used on high inertia loads that require a long acceleration or have shock loading that causes repetitive motor inrush.



The overload class that *MiTek* normally specifies for equipment is a Class 10. Since it is possible to burn out a motor in less than 20 seconds, we have chosen to protect the motor with the highest degree of protection.

Codes And Standards

NFPA 79—Electrical Standard for Industrial Machinery, 2002

7.3.1.1 Motors. Motor overload protection shall be provided to each motor in accordance with Article 430, Part III, of NFPA 70, *National Electrical Code*.

NEC 2002—National Electrical Code

430.32 (A) (1) Separate Overload Device. A separate overload device that is responsive to motor current. This device shall be rated at no more than the percentages shown in Table 2-1.

Table B-1: Full Load Current Tolerances

Nameplate Full Load Current Rating	% Allowed Above Full Load Current Rating
Service Factor of 1.15	125%
Motors with a marked temperature rise of 40°C or less	125%
All other motors	115%

Example 1

15 hp, 208V, 3 phase, induction motor, 40°C rise, *design B*, *FLA* 48 amps. Overload Protection = 48 amps times 125% = 60 amps

Example 2

25 hp, 208V, 3 phase, induction motor, 1.15 s.f., *design C*, *FLA* 72A. Overload Protection = 72 amps times 125% = 90 amps

Example 3

40 hp, 208V, 3 phase, wound rotor motor, FLA 118 amps. Overload Protection = 118 amps times 115%=136 amps

The motor overloads must be calculated using the nameplate current and not from Tables 430-148 or 430-150 of the National Electrical Code.



In Example 1, the motor has a 40°C rise, the O.L. unit is sized at 125% of the full load motor current.

In Example 2, the motor has a s.f. (service factor) of 1.15. The O.L. unit is sized at 125% of the full load motor current.

In Example 3, where neither of the two conditions exists, it is sized at 115%.

Glossary of Overload Terms

Full Load Amps (FLA)

This is the current flow required by a motor during normal operation under normal loading to produce its designated horsepower. Motors having nothing attached to their shaft will draw less than the FLA current.

Insulation Class

The National Electrical Manufacturers Association (NEMA) has established insulation classes to meet motor temperature requirements found in different operating environments. The four insulation classes are A, B, F, and H. Class F is commonly used. Class A is seldom used. Before a motor is started, its windings are at the temperature of the surrounding air. This is known as ambient temperature. NEMA has standardized on an ambient temperature of 104°F, or 40°C for all motor classes.

Temperature rises in the motor as soon as it is started. The combination of ambient temperature and allowed temperature rise equals the maximum winding temperature in a motor. A margin is allowed for a point at the center of the motor's windings where the temperature is higher. This is referred to as the motor's hot spot.

The operating temperature of a motor is important to efficient operation and long life. Operating a motor above the limits of the insulation class reduces the motor life expectancy. A 50°F (10°C) increase in the operating temperature can decrease the life expectancy of a motor by as much as 50%.

Table B-2: Maximum Winding Temperature

Class A	Class B	Class F	Class H
221°F (105°C)	266°F (130°C)	311°F (155°C)	356°F (180°C)

Locked Rotor Amps

Also known as inrush current, locked rotor amps is the amount of current the motor can be expected to draw under starting conditions when full voltage is applied. This is the current taken from the supply line at rated voltage and frequency with the rotor at rest.

Motor Load

A motor provides the conversion of electrical energy to mechanical energy that enables a machine to do work. The energy that a machine requires from a motor is known as the

motor load. The motor load “seen” by a motor is dependant upon how the load is connected to the motor, the dimensions of the load, and the weight of the load.

A load connected to a motor by a gearbox reduces the load by the square of the gear ratio. If a load is attached to a motor through a 3:1 gear ratio, the load is 1/9 of the load the motor would see if the load were attached directly to the motor.

A round object attached to the motor shaft has a load related to the square of the radius of the object. If a 16" saw blade is a load of weight multiplied by the radius squared, the load is $8^2 \times \text{weight} = 64 \times \text{weight}$. A 20" saw blade is a load of $10^2 \times \text{weight} = 100 \times \text{weight}$. The 20" saw blade is 56% more load than the 16" saw blade due to the dimensions.

A motor load is directly related to the weight of an object. A 16" blade weighs 9.28 pounds. A 20" blade weighs 14.61 pounds, or 5.33 pounds more. The 20" blade is 56% more load than the 16" blade due to weight. Remember, weight is the volume of an object times its density, so weight is also related to the dimensions.

In the example of the saw blades, the combined effect of the longer radius, and longer weight means the 20" saw blade is approximately 125% more load on a motor than a 16" saw blade, which partially explains why motors on quads 1 and 4 are more likely to burn out or trip an overload.

NEMA Design Ratings

NEMA ratings refer to the torque ratings. The following ratings apply to motors:

NEMA B

The NEMA B motor's percentage of slip ranges from 2 to 4%. It has medium values for starting or locked rotor torque, and a high value of breakdown torque.

NEMA A

The NEMA A motor is similar in many ways to the NEMA B motor. It typically has a higher value of locked rotor torque and its slip can be higher.

NEMA C

The NEMA C motors are well suited to starting high-inertia loads. This is because they have high locked rotor torque capability. Their slip is around 5%, and their starting current requirement is average.

NEMA D

The NEMA D motor is found in heavy duty, high-inertia applications. It has high values of slip (up to 8%), and very high locked rotor torque capability.

Service Factor (s.f.)

A motor designed to operate at its nameplate horsepower rating has a service factor of 1.0. Some applications may require a motor to exceed the rated horsepower. In these cases a motor with a service factor of 1.15 can be specified. The service factor is a multiplier that may be applied to the rated power. A 1.15 service factor motor can be operated 15% higher than the motor's nameplate horsepower.

Trip Class

Overload relays are rated by a trip class, which defines the length of time it will take for the relay to trip in an overload condition. The most common trip classes are Class 10,

Figure B-3: Trip Times for Trip

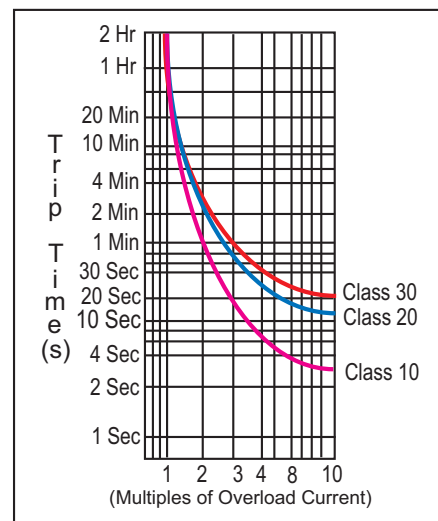

Class 20, and Class 30. Class 10, for example, has to trip the motor off-line in 10 seconds or less at 600% of the full load amps. This is usually sufficient time for the motor to reach full speed.

Understanding Motor Starting Problems

There are three major sources of motor starting problems: voltage source problems, control circuit problems, and drive faults. Diagnosing and resolving these problems can be a time-consuming process, but some time can be saved by using an organized process of elimination. The following sections address the most common sources of motor starter problems.

WARNING	
	<p>ELECTROCUTION HAZARD.</p> <p>Always turn the power off by activating an E-stop when the equipment is not in operation.</p> <p>Always verify that all power to the machine has been turned off and follow approved lockout/tagout safety procedures (OSHA 29 CFR 1910.147) before performing any maintenance on this equipment.</p> <p>If it is absolutely necessary to troubleshoot an energized machine, follow NFPA 70E for proper procedures and personal protective equipment.</p>

Voltage Source Problems

1. Check the incoming power source. Verify that all three phases of power have the proper voltage using a digital multimeter set to voltage mode. If any of the three phases of incoming power are low or missing, disconnect power at the primary disconnect switch and reset the circuit breaker or replace the fuse.
2. Before restoring power at the primary disconnect, verify that there are no phase-to-phase or phase-to-ground shorts at the motor starter line contactors. If necessary, replace starter contacts to correct shorts.
3. Check that motor thermal overloads have not been tripped. Reset the overloads by pressing the reset pushbutton.
4. Check the motor starter leads for phase-to-phase and phase-to-ground shorts. Check for discoloration, hot spots, melted wire or damaged fuses. Correct the motor lead wiring if necessary.

5. Check the motor leads for phase-to-phase and phase-to-ground shorts. Check for discoloration, hot spots, melted wire or damaged fuses. Replace the motor if necessary.
6. Determine if motor windings are breaking down by testing the motor insulation with an insulation tester or taking the motor to a repair shop for testing.
7. Disconnect the motor from its load. Start the motor. If it runs correctly, the problem is associated with the mechanical drive train. If it does not run correctly, replace the motor bearings.

Control Circuit Problems

1. If the incoming power source has all three phases of power, check the motor starter overloads. Reset the motor starter overloads by pressing the reset button.
2. Verify that the control voltage transformer fuse is operating correctly using a digital multimeter set to Ohms. The multimeter should have a low reading. If the multimeter registers no reading or an infinite reading, replace the fuse.
3. Disconnect the motor starter contactor coil. Check for a short or ground. If necessary, replace the motor starter coil.
4. Check the control circuit wiring to the contactor coil while the coil is still disconnected. If a short or ground is present, disconnect the field wiring circuit to the motor starter. Determine whether the problem is with the motor contactor overload circuit or the field control wiring.
5. If a ground is found in the motor starter overloads circuit, replace the overloads. Reconnect the starter coil and control field wiring.
6. If a ground is found in the field wiring circuit, clear the ground. Reconnect the starter coil and control field wiring.
7. Check for an open circuit in the motor overloads or control circuit by using a digital multimeter set for Ohms to verify the motor overloads control circuit is working correctly.
8. Check the PLC contact closure, relay contact closure or start/stop pushbutton circuit that supplies the start signal to the motor starter.

Drive Faults

Before troubleshooting a drive fault, determine whether the fault is a motor, drive, or application fault. Use the fault codes of the drive. If you are unable to locate the source of the fault, contact MiTek Customer Service.

Drawing Set

Appendix C

Drawings are inserted at the back of the manual.

Table C-1: Attached Drawings

Description	Drawing Number
Sample layout, 10-table side-eject system	66675
Gantry assembly, 14-ft	68000
Short bogie wheel	63025
Long bogie wheel	68030
Bogie wheel	68027
Drive wheel assembly	68175
Drive wheel assembly	68280
Gantry roller assembly, Tee-Lok Line	68285
Gantry roller assembly, Robbins line	68290
Roller assembly, take-up	68510
Bus bar	69596
Electrical assembly	90039



Document Evaluation

Appendix D

A form is included in this appendix so you can provide MiTek with feedback on the usefulness of this manual. We make an ongoing effort to improve the value of our documentation, and your views are important to us.

Please follow the instructions on the form to provide us with comments or suggestions that will help us improve the quality of our documentation services.

Document Evaluation Form

We appreciate your comments on how we can make this document more useful.

Document Identification:

Roller Gantry	Operation and Maintenance Manual	001012
---------------	----------------------------------	--------

General Ratings:

	Poor	Fair	Good	Excellent
Content	<input type="checkbox"/>	<input type="checkbox"/>	<input type="checkbox"/>	<input type="checkbox"/>
Organization	<input type="checkbox"/>	<input type="checkbox"/>	<input type="checkbox"/>	<input type="checkbox"/>
Accuracy	<input type="checkbox"/>	<input type="checkbox"/>	<input type="checkbox"/>	<input type="checkbox"/>
Clarity	<input type="checkbox"/>	<input type="checkbox"/>	<input type="checkbox"/>	<input type="checkbox"/>
Completeness	<input type="checkbox"/>	<input type="checkbox"/>	<input type="checkbox"/>	<input type="checkbox"/>
Examples/Illustrations	<input type="checkbox"/>	<input type="checkbox"/>	<input type="checkbox"/>	<input type="checkbox"/>
Readability	<input type="checkbox"/>	<input type="checkbox"/>	<input type="checkbox"/>	<input type="checkbox"/>

Compared to other truss machinery manufacturers' documentation, how would you rate this document?

- Poor
 Fair
 Good
 Excellent

There is room for specific suggestions on the next page. Document general comments here.

Document Evaluation Form (cont'd)

Identify any inaccuracies in the document.

What are the three best features of the document?

What are the three worst features of the document?

What did you like/dislike about the illustrations?

Your Name:

Date:

Company Name:

Address:

Phone:

Email:

Please mail this form to:

MiTek
Machinery Operations
301 Fountain Lakes Industrial Drive
St. Charles, MO 63301
Attn: Engineering Manager

Or fax this form to:

636-328-9218
Attn: Engineering Manager

If you do not receive a reply within 45 days, please call our Customer Service Department and ask for the Documentation Specialist or Engineering Manager: 800-523-3380.

Glossary

actuate	to activate, put into action
aisle pad	a type of jiggging used when a connector plate needs to be embedded where the table surface gives way to a walk-through aisle
amperage	the strength of an electric current, expressed in amperes
anchor plate	a steel plate that holds the tables in place; it is anchored to the concrete floor and the tables are welded to it
auto-eject	a pneumatic system that raises the truss off the tables and automatically places the truss on the stand-alone conveyors with the use of a transfer roller
bumper	a safety device on each corner of the gantry head (for a total of 4); when the bumper is depressed, the gantry head motion stops
bus bar	an electrical device that allows multiple gantry heads to be used simultaneously
connector plate	the nail-plate that is embedded into the production material to hold it together
cushion	an attribute of a hydraulic cylinder that allows adjustment of the pressure in each cylinder
directional buttons	the 2 black buttons on the pendant control station that tell the gantry head which direction to move
end-eject	a pneumatic system that raises the truss off the tables and allows the truss to be manually pushed or pulled off the end of the tables; this system requires that the gantry head rolls back over the truss or a device must be installed to raise the gantry head when it is parked
gantry head	the entire traveling weldment that houses the Roller to embed the connector plates
inner side	refers to the end of the gantry head housing; the side closest to the tables; both ends have an inner side—one can see the inner side of both ends when standing on or between the tables

Glossary

jigging	any of several devices used to hold the truss in place on the tables
joystick	an option that replaces the pendant control station to control movement of the gantry head
layout	a scaled diagram of the location of components and the space that they occupy
leveling screws	large cap head screws that thread into the table legs and allow the table height to be adjusted and leveled
light bar	the perimeter access guarding device that uses multiple light beams to detect when something is in the way of the gantry head and stops the machine to prevent injury or damage; the RoofTracker uses a set of 3-beam light bars on both sides of the gantry head
limit switch	an electro-mechanical device that consists of an actuator mechanically linked to a set of contacts; when an object comes into contact with the actuator, the device operates the contacts to make or break an electrical connection
lockout/tagout	a means of isolating a piece of equipment from its energy source so maintenance can safely occur; guidelines provided in OSHA 29 CFR 1910.147
motor end	used to indicate which end of the gantry head is being discussed; the end of the gantry head that houses the motor
operator control interface	the method in which the operator controls the machine; it may be a touch screen, a control panel, etc.
outer side	refers to the end of the gantry head housing; the side farthest from the tables; both ends have an outer side—one can see the outer side of the one end when standing at the pendant control station
pendant control station	where the operator stands to use the pendant that controls movement of the gantry head
plate	see <i>connector plate</i>

Glossary

PLC	Programmable Logic Controller; a solid-state control device that can be programmed to control process or machine operations. It consists of five basic components: processor, memory, input/output module, the power supply, and the programming device.
port	a connection point for a peripheral device
potentiometer	a control knob that is a dial; allows a range of values to be set by turning the dial, commonly found on the PLC
proximity switch	a switch that uses an electromagnetic field to detect when an object is near, there is no physical contact between the object and the switch; inductive proximity switches detect only metal objects, capacitive proximity switches can sense both metallic and non-metallic objects
puck	a type of jigging that is small and round
qualified person	a person or persons who, by possession of a recognized degree or certificate of professional training, or who, by extensive knowledge, training, or experience, has successfully demonstrated the ability to solve problems relating to the subject matter and work—ANSI B30.2-1983; one who has skills and knowledge related to the construction and operation of the electrical equipment and installations and has received safety training on the hazards involved—NEC2002 Handbook
receiver bar	the light bar that receives the signal from the transmitter bar; every light bar set consists of a receiver bar and a transmitter bar
regulator	a component of the pneumatic system that connects to the main air source and regulates the air pressure allowed into the system
Roller	the large roller inside the gantry head that innately embeds the plates into the truss
setup valve	a component of the pneumatic system that control the flow of air to the rest of the setup

Glossary

side-eject	a pneumatic system that raises the truss off the tables and allows the truss to be manually pushed or pulled off the side of the table and onto the stand-alone conveyors
slider pad	a type of jigging used when a connector plate needs to be embedded where the table surface gives way to a slot for the Ejector
solenoid	an assembly used as a switch consisting of a coil and a metal core free to slide along the coil axis under the influence of the magnetic field
stand-alone conveyor	the conveyor system that carries the truss from the tables to the Finish Roller and out to the stacker
stop	a type of jigging that is long and straight
take-up bearing	adjusts the height of the roller
torque	a turning or twisting force
transfer roller	a motorized roller sitting perpendicular to the tables on an auto-eject system; it automatically transfers the truss from the Ejectors to the stand-alone conveyors
transmitter bar	the light bar that transmits the signal to the receiver bar; every light bar set consists of a receiver bar and a transmitter bar
VFD	Variable Frequency Device; controls the speed of the cycle
voltage	Equal to the difference of electric potential between two point on a conducting wire carrying a constant current of one ampere when the power between the points is one watt

Index

B

bearings
 lubrication 37
bogie wheels adjustment 32

C

calibration 27
caution logo viii
centerlines
 terminology 8
chains
 adjusting tension 45
checklists
 installation 17
cleaning 36
Customer Service 3

D

danger logos viii
delivery 13
disconnect switch 19
document evaluation 62
drawings
 description 60
 drawing numbers 60
drive wheel chain 28
 adjusting tension 45

E

electrical
 connecting power 16
 installation
 electrical
 disconnect enclosure 16
 requirements 12
emergency stops, *see* E-stop
environment 12
environmental logo viii
E-stop
 pushbutton 20

F

floor structure 11

G

gearboxes 38

H

hazard indicator viii

I

installation
 checklist 17
 customer responsibilities 11
 delivery 13
 electrical 16
 lifting 16

L

lockout/tagout
 graphic 2, 25
 guidelines xi
 procedure xii, xiv, xxiii, xxv
lubrication
 bearings 37
 general 37

M

maintenance
 safety during 25
manual
 Maintenance
 how to use 2
 introduction 1
 navigation 2
 purpose 1
 purpose 1
motor drive chain

Index

adjusting tension 45

N

notice logo viii
notice of change vi

O

operation
stopping 19

P

page change vi
prior to installation
requirements
electrical 12
space 11
responsibilities
customer 11
MiTek 10
Purpose 1

Q

QD sprocket adjustment 29

R

reporting errors v
restricted zones xvi, xxviii
return goods v
Roller Gantry lubrication chart 34
roller setting adjustment 32

S

safety
lockout/tagout xi, 2
restricted zones xvi, xxviii

safety indicators viii
safety rules viii, xviii
specifications
general 6
Speed reducer/gearbox chain 28
sprocket adjustment 29
stop motion 19

T

training 12
truss terminology 8

U

unloading 13, 14
unpacking 13, 14

W

warning logo viii