

# Operation and Maintenance Manual



## Finish Roller

Roller Press

# Operation and Maintenance Manual

# Finish Roller

Roller Press



*U.S. and other patents pending.*

**MiTek**  
**Machinery Division**  
**301 Fountain Lakes Industrial Drive**  
**St. Charles, MO 63301**  
**phone: 800-523-3380**  
**fax: 314-344-9977**  
**www.mii.com**

001010	
Revision	D
Revision date	18 March 2010
Print date	9 January 2024
Revised by	R. Tucker
Reviewed by	M. Bouckaert
Approved by	M. Kanjee

Applicability: PN 63800-xxxV

# Contents

<b>Preliminary Pages</b>	
<b>Contents</b> .....	<b>ii</b>
<b>Legal Notice</b> .....	<b>v</b>
<b>Notice of Change</b> .....	<b>vi</b>
<b>Safety (English)</b>	
<b>Safety Indicators</b> .....	<b>viii</b>
<b>Safety Rules</b> .....	<b>ix</b>
<b>Lockout/Tagout</b> .....	<b>xi</b>
Lockout/Tagout Guidelines .....	xi
Electrical Lockout/Tagout Procedures .....	xii
<b>Troubleshooting With an Energized Machine</b> .....	<b>xv</b>
<b>Restricted Zone</b> .....	<b>xvi</b>
<b>Seguridad (Español)</b>	
<b>Indicadores de seguridad</b> .....	<b>xviii</b>
<b>Reglas de seguridad</b> .....	<b>xix</b>
<b>Bloqueo/Etiquetado</b> .....	<b>xxii</b>
Pautas de bloqueo/etiquetado .....	xxii
Procedimientos de bloqueo/etiquetado eléctricos . . .	xxiii
<b>Solución de problemas con una máquina energizada</b>	<b>xxvi</b>
<b>Zonas restringida</b> .....	<b>xxvii</b>
<b>General Information</b>	<b>Chapter 1</b>
<b>Introduction to the Equipment</b> .....	<b>1</b>
Purpose of the Equipment .....	1
Description of the Equipment .....	1
<b>Contacting MiTek</b> .....	<b>2</b>
<b>General Specifications</b> .....	<b>3</b>
<b>Truss Terminology</b> .....	<b>4</b>
<b>Prior to Installation</b>	<b>Chapter 2</b>
<b>MiTek's Responsibilities</b> .....	<b>6</b>
Prior to Installation .....	6
<b>Customer's Responsibilities</b> .....	<b>7</b>
Location Requirements .....	8
Electrical Requirements .....	8
Mechanical Requirements .....	9
Shipping Information .....	9
Customer-Supplied Parts .....	10
<b>Training Provided</b> .....	<b>10</b>
<b>Installation</b>	<b>Chapter 3</b>
<b>Responsibilities During Installation</b> .....	<b>11</b>
<b>Delivery</b> .....	<b>11</b>
Checking for Damage .....	11
Unloading .....	12
Unpacking .....	12

# Contents

<b>Equipment Layout</b> .....	<b>13</b>
Assembly .....	13
Forklift .....	14
<b>Electrical System</b> .....	<b>14</b>
Checking Existing Wiring .....	14
Connecting Power to the Equipment .....	14
<b>Installation Checklist</b> .....	<b>15</b>
<b>Operation</b> .....	<b>Chapter 5</b>
<b>Safety Hazards During Operation</b> .....	<b>16</b>
<b>Things to Know Before You Begin</b> .....	<b>18</b>
Stopping the Machine .....	18
Starting the Machine .....	18
<b>Operator Control Interface</b> .....	<b>19</b>
<b>Operating Procedure</b> .....	<b>20</b>
Procedure Under Normal Conditions .....	20
Restart Procedure .....	21
<b>Maintenance</b> .....	<b>Chapter 6</b>
<b>Introduction to Maintaining Your Equipment</b> .....	<b>22</b>
<b>Performing Maintenance Safely</b> .....	<b>23</b>
Before Operating This Equipment .....	23
Lockout/Tagout .....	23
Making Adjustments to the Machine .....	24
Wearing Personal Protective Equipment .....	24
Conducting Safety Tests .....	24
<b>Overview Graphics</b> .....	<b>25</b>
<b>Adjustments</b> .....	<b>25</b>
Adjusting the Speed Reducer/Gearbox Chain .....	25
Aligning/Adjusting the Sprocket .....	26
Adjusting the QD Sprocket .....	26
Installing the QD Sprocket .....	27
Adjusting the <i>Finish Roller</i> Press Setting .....	28
<b>Cleaning, Lubricating, and Inspecting</b> .....	<b>29</b>
Cleaning .....	29
Lubricating .....	30
<i>Checking Operation of the Finish Roller Press</i> .....	31
<b>Motors and Gearboxes</b> .....	<b>32</b>
Electric Motor .....	32
Replacing a Brake Pad .....	33
Adjusting the Air Gap .....	34
Adding and Changing Oil .....	36
Replacing the Motor .....	37
<b>Troubleshooting</b> .....	
Appendix A .....	38
<b>Safety Notes for Troubleshooting</b> .....	<b>38</b>
<b>Operational Notes for Troubleshooting</b> .....	<b>39</b>

# Contents

<b>Parts List</b>	
Appendix B .....	41
<b>Navigating the Parts List Appendix</b> .....	<b>41</b>
Finding the Part Number .....	41
<b>Safety Notes When Replacing Parts</b> .....	<b>42</b>
<b>Drawing Set</b>	
Appendix D .....	43
<b>Document Evaluation</b>	
Appendix E .....	44
<b>Index</b>	<b>47</b>
<b>Glossary</b>	<b>49</b>

# Legal Notice

## Patents

Made and sold under one or more of the following patents:

U.S. 37,797	U.S. 5,468,118
U.S. 5,553,375	U.S. 6,079,325
U.S. 6,145,684	U.S. 6,330,963
U.S. 6,405,916	U.S. 6,651,306
U.S. 6,807,903	Other Patents Pending

## Return Goods Policy

Return goods cannot be accepted without prior authorization and are subject to a restocking charge. The Seller certifies the articles specified herein were produced in compliance with all provisions of the Fair Labor Standards Act of 1938, as amended, including Section 12.—Rev. 6/98

## Reporting Errors and Recommending Improvements

To report errors or recommend improvements to this manual, please complete the Document Evaluation Form in the appendices. Mail or fax the form to:

MiTek, Machinery Division  
4203 Shoreline Drive  
Earth City, MO 63045  
Attn: Engineering Manager  
Fax: 314-298-3439

Your support in helping MiTek provide unsurpassed machinery and support is appreciated.

# Notice of Change

Use this page to record Service Bulletins and Notices that you receive to keep your manual updated.

## Finish Roller Press

Service Bulletin or Notice #	Dated	Title

# **Safety (English)**

For safety information in Spanish, refer to page vii.

**Be Careful.  
Be Safe.**





## Safety Indicators

The following safety alert symbols and signal words are used throughout this document to indicate safety hazards. Please pay careful attention when you see them. The level of severity differs for each symbol or signal word.

Failure to comply with the instructions accompanying each safety alert symbol may result in property damage, personal injury, or even death. Personnel must follow all safety procedures and practices to ensure the safest possible operation of this equipment. However, at no time is this document a substitute for common sense. Personnel must ensure that the work environment is safe and free of distractions.



### **DANGER**

Indicates an imminently hazardous situation which, if not avoided, is likely to result in death or serious injury.



### **WARNING**

Indicates a potentially hazardous situation which, if not avoided, may result in death or serious injury.



### **CAUTION**

When CAUTION is used *with* the safety alert symbol shown here, it indicates a potentially hazardous situation which, if not avoided, may result in minor or moderate injury.

When CAUTION is used *without* the safety alert symbol shown here, it indicates a potentially hazardous situation which may result in equipment damage.

**NOTICE**

### **NOTICE**

Calls attention to information that is significant to understanding the operation at hand.

**ENVIRONMENTAL**

### **ENVIRONMENTAL**

Applies to conditions that may affect the environment but do not have an immediate, direct effect on personnel or equipment.

## Safety Rules

Because it is impossible to anticipate every circumstance that might involve a hazard, the safety information provided in this equipment manual and on the machine is not all-inclusive. If this machine is operated or serviced using a procedure not specifically recommended by the manufacturer, the procedure shall be approved by a professional engineer to ensure it will not render the equipment unsafe. Use extreme caution and common sense at all times!

### Know Your Equipment

- Read this manual completely before using or maintaining the equipment. Do not operate this machine unless you have a thorough knowledge of the controls, safety devices, emergency stops, and operating procedures outlined in this manual.
- Read and follow all safety notes. Failure to comply with these instructions may result in economic loss, property damage, and/or personal injury including death.
- Refer to the lockout/tagout guidelines on the following pages to safely perform maintenance and troubleshooting of this equipment.
- Observe and obey all safety labels. Replace worn labels immediately.
- Use this equipment solely for the purpose described in this manual.
- Only qualified personnel should attempt to operate or perform maintenance on this equipment. “Qualified personnel” is defined as:

*...a person or persons who, by possession of a recognized degree or certificate of professional training, or who, by extensive knowledge, training, or experience, has successfully demonstrated the ability to solve problems relating to the subject matter and work—ANSI B30.2-1983*

*...one who has skills and knowledge related to the construction and operation of the electrical equipment and installations and has received safety training on the hazards involved—NEC 2002 Handbook*

### Personal Safety

- Always wear safety glasses and hearing protection in an industrial environment.
- Utilize a filtering facepiece (dust mask) when working near sawdust.
- Wear proper clothing and appropriate personal protective equipment (e.g., safety glasses and hearing protection.) Do not wear loose clothing or jewelry. Confine long hair by tying it back.
- Use caution when lifting heavy parts or material.

### Installing the Equipment

- Follow installation instructions completely.

### **Lockout/Tagout**

- Before performing maintenance on the pneumatic or hydraulic systems, bleed the lines to eliminate pressure.
- Lockout/tagout all energized systems before performing maintenance on them. Refer to the *Lockout/Tagout Guidelines* section on page xi.

### **Keeping a Safe Environment**

- Keep children away. All visitors should be kept a safe distance from the work area. Hazards may not be apparent to individuals unfamiliar with the machine.
- Keep work areas well lit.
- Keep the work area clean and free of any trip or slip hazards.
- Do not use the equipment in damp or wet locations, or expose it to rain or snow.

### **Operating and Maintaining the Equipment**

- Ensure that all people, tools, and foreign objects are clear of the restricted zones before operating this equipment. The restricted zones are shown on page xvi.
- Perform safety tests to ensure all E-stops are working properly before operating the equipment at the initial startup, after performing any maintenance, and in accordance with the maintenance schedule.
- In case of machine malfunction, stop the machine immediately using an E-stop and report the malfunction to a supervisor.
- Never leave the machine running unattended. Turn the power off! Do not leave the machine until all parts have come to a complete stop and all electrical power has been shut off.
- Check for worn or damaged parts regularly. Repair or replace them immediately.
- Keep the hydraulic, pneumatic, and electrical systems in good working order at all times. Repair leaks and loose connections immediately. Never exceed the recommended pressure or electrical power.
- Check that all safety devices are in working order before each shift starts. All protective guards and safety devices must be in place before and during use of the machine. Never disconnect or bypass any safety device or electrical interlock.
- Periodically inspect the quality of the finished product.

### **Electrical Safety**

- Do not use any liquids in the interior of electrical cabinets.
- When using solvents on and around the machine, remove power to the machine to eliminate the chance of sparking, resulting in explosion or fire. Wear a respirator approved for use with solvents. Wear protective clothing, gloves, and safety glasses.

## Lockout/Tagout

### Lockout/Tagout Guidelines

**All lockout/tagout guidelines must be met according to OSHA 29 CFR 1910.147.** A specific procedure should be included in your company's energy control program. This manual is not intended to replace your company's de-energizing or lockout/tagout procedure required by OSHA, but merely to provide general guidance.

The term "lockout," as used in this manual, means placing a lockout device on any and all energy sources to ensure that the energy isolating device and the equipment being controlled cannot be re-energized or operated until the lockout device is removed. The photos on the next page show where the electrical disconnects are located for this machine.



- Energy sources include electrical, mechanical, hydraulic, pneumatic, chemical, thermal, or other energy.
- In the case of electrical energy sources, the main power and control power to the machinery must be turned off and physically locked in the "off" position.
- A lockout device is usually a keyed padlock.
- If more than one person is working in a restricted zone, use a group lockout device that will allow each person to use a lock that can be removed only by the person performing the maintenance.

"Tagout" means that a prominent warning is securely fastened to an energy-isolating device to indicate that the equipment shall not be operated.

## Electrical Lockout/Tagout Procedures

### When Working on a Machine Outside the Machine’s Main Electrical Enclosure



If working on the electrical transmission line to the machine, follow the procedure on page xiv.

Before performing maintenance on any machine with electrical power, lockout/tagout the machine properly. When working on a machine outside of the machine’s main electrical enclosure, not including work on the electrical transmission line to the machine, follow your company’s approved lockout/tagout procedures which should include, but are not limited to the steps here.

1. Engage an E-stop on the machine.
2. Turn the disconnect switch handle to the “off” position. See Figure 5-1.

<b>WARNING</b>	
	<p><b>ELECTROCUTION HAZARD.</b></p> <p><b>When the disconnect switch is off, there is still live power within the disconnect switch’s enclosure. Always turn off power at the building’s power source to the equipment before opening this electrical enclosure!</b></p>

3. Attach a lock and tag that meet OSHA requirements for lockout/tagout.
4. Restrain or de-energize all pneumatic components, hydraulic components, and other parts that could have live or stored power.

**Figure 5-1: Lockout/Tagout on the Main Electrical Enclosure**

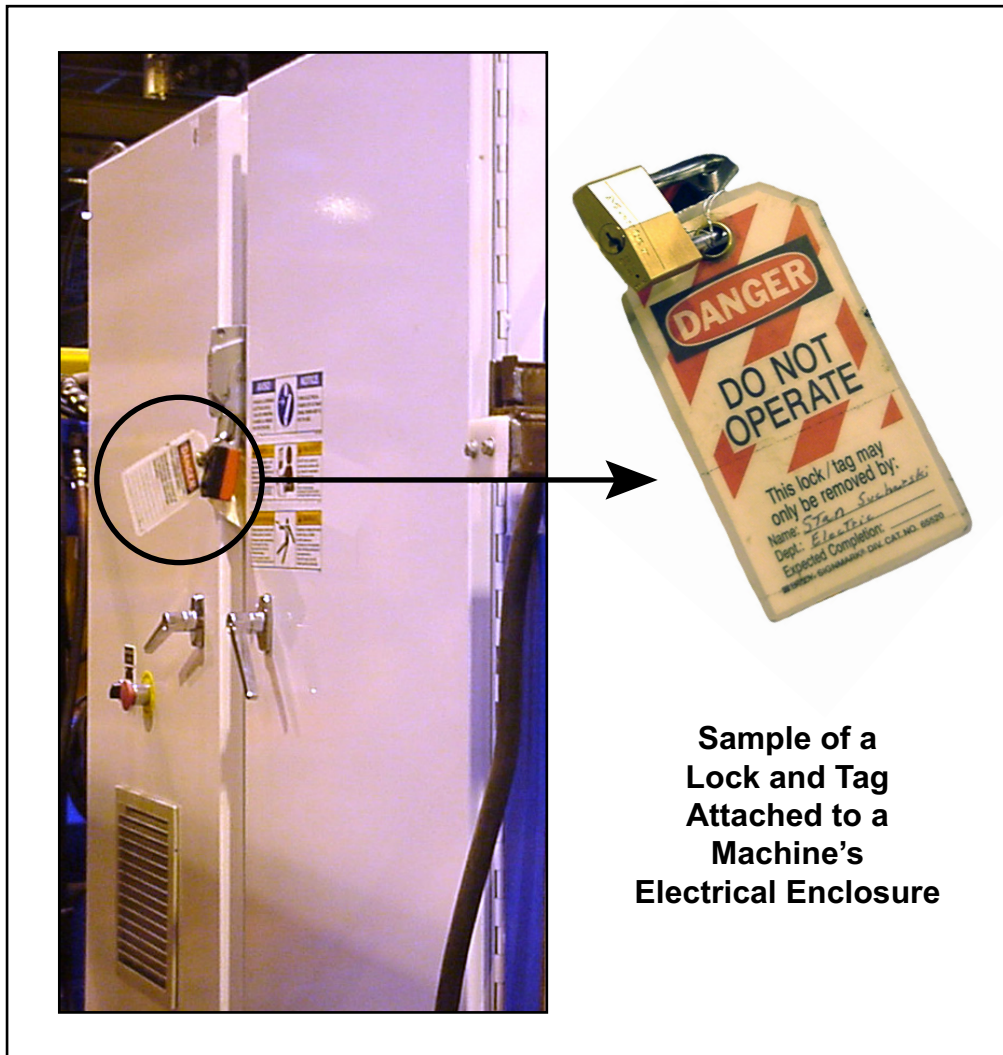

### When Working on a Machine Inside the Machine's Main Electrical Enclosure or in the Electrical Transmission Line to the Machine

Before opening the main electrical enclosure, or attempting to repair or replace an electrical transmission line to the machine, lockout/tagout the machine properly. Follow your company's approved lockout/tagout procedures which should include, but are not limited to the steps here.

1. Engage an E-stop on the machine.
2. Shut the power to the machine off at the machine's power source which is usually an electrical service entry panel on the facility wall. One example of a locked-out power source panel is shown in Figure 5-2.
3. Attach a lock and tag that meets OSHA requirements for lockout/tagout.
4. Open the door to the enclosure in which you need access, and using a multimeter, verify that the power is off.

**Figure 5-2: Lockout/Tagout on the Power Source Panel**



tagout the machine properly. Follow your company's approved lockout/tagout procedures.

## Troubleshooting With an Energized Machine

Only a qualified electrician, using the personal protective equipment and following the procedures recommended in NFPA 70E should ever attempt service or repair of or near an energized area or component of the machine.

Whenever maintenance is performed while the equipment is electrically energized, there is a potential electric arc flash hazard. Refer to NFPA 70E for the personal protective equipment required when working with electrically energized components. Pneumatic and hydraulic components may move unexpectedly if not de-energized. Physically restrain any components capable of movement when working on or near those components.



## Restricted Zone

<b>DANGER</b>	
	<p>Stay out of the restricted zone when equipment is in use. Serious injury or death may result if personnel are in the restricted zone.</p>

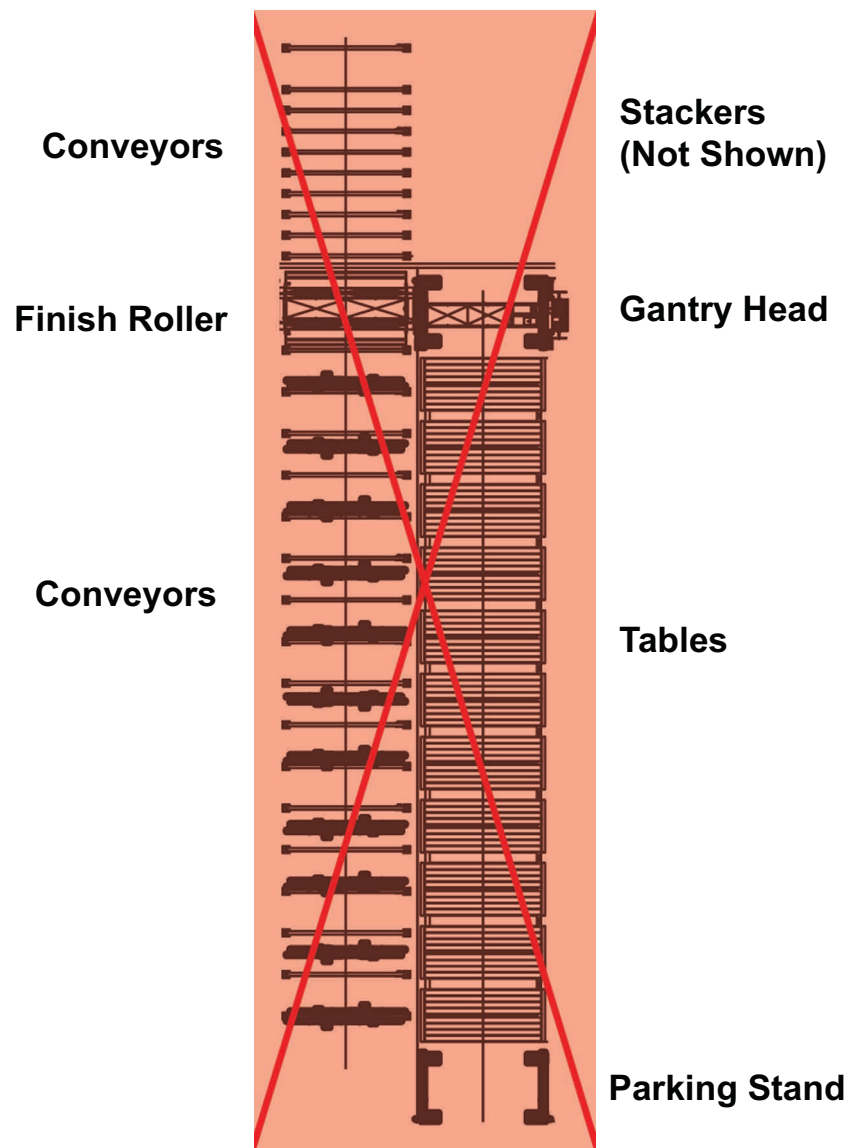

# **Seguridad (Español)**

**Sea cuidadoso.  
Protéjase.**



## Indicadores de seguridad

Los siguientes símbolos de alerta de seguridad y palabras de advertencia se utilizan a lo largo de este documento para indicar riesgos de seguridad. Preste suma atención cuando los vea. Cada símbolo o palabra indica un nivel de gravedad diferente.

El no cumplimiento de las instrucciones que acompañan a cada símbolo de alerta de seguridad puede producir daños a la propiedad, lesiones personales e incluso la muerte. El personal debe seguir todos los procedimientos y prácticas de seguridad establecidos para asegurar el uso más seguro posible de este equipo. No obstante, en ningún caso este documento reemplaza el sentido común. El personal debe asegurarse de que el entorno de trabajo sea seguro y esté libre de distracciones.



### **PELIGRO**

Indica una situación de riesgo inminente que, si no se evita, pudiera producir la muerte o lesiones graves.



### **ADVERTENCIA**

Indica una situación potencialmente peligrosa que, si no se evita, puede producir la muerte o lesiones graves.



### **PRECAUCIÓN**

Cuando la PRECAUCIÓN se utiliza **con** el símbolo de alerta de seguridad aquí ilustrado, indica una situación potencialmente peligrosa que, si no se evita, puede producir lesiones menores o moderadas.

Cuando PRECAUCIÓN se utiliza **sin** el símbolo de alerta de seguridad aquí ilustrado, indica una situación potencialmente peligrosa que podría producir daños al equipo.

### **AVISO**

### **AVISO**

Llama la atención a información importante para entender la operación que se desea realizar.

### **AMBIENTAL**

### **AMBIENTAL**

Se aplica a condiciones que pueden afectar el entorno pero que no tienen un efecto inmediato o directo sobre el personal o el equipo.

## Reglas de seguridad

Debido a la imposibilidad de anticipar todas las circunstancias que podrían constituir un riesgo, la información de seguridad suministrada en este manual del equipo y sobre la máquina no es exhaustiva. Si se utiliza o realiza el mantenimiento de esta máquina utilizando un procedimiento no recomendado específicamente por el fabricante, el procedimiento deberá ser aprobado por un ingeniero profesional para asegurarse de que no afecte la seguridad del equipo. ¡Manéjese! siempre con suma precaución y sentido común!

### Conozca su equipo

- Lea este manual en su totalidad antes de utilizar o mantener el equipo. No utilice esta máquina a menos que esté perfectamente familiarizado con los controles, los dispositivos de seguridad, los frenos de emergencia y los procedimientos operativos que se describen en este manual.
- Lea y siga todas las notas de seguridad. El no cumplimiento de estas instrucciones podría producir pérdidas económicas, daños a la propiedad y lesiones personales, incluida la muerte.
- Refiérase a las pautas de bloqueo/etiquetado proporcionadas en las siguientes páginas para realizar el mantenimiento y solucionar problemas de este equipo en forma segura.
- Observe y cumpla con todas las etiquetas de seguridad. Cambie las etiquetas gastadas inmediatamente.
- Utilice este equipo únicamente para el propósito que se describe en este manual.
- Sólo personal calificado debe intentar utilizar o realizar el mantenimiento de este equipo. Por "personal calificado" se entiende:

*...una persona o personas que, por el hecho de poseer un título o certificado de capacitación profesional reconocido o que, por sus amplios conocimientos o experiencia, han demostrado con éxito estar capacitados para resolver problemas relacionados con el tema y el trabajo en cuestión—ANSI B30.2-1983*

*...una persona que posee habilidades y conocimientos relacionados con la construcción y uso de equipos e instalaciones eléctricas y que ha recibido capacitación en seguridad sobre los riesgos posibles—NEC 2002 Handbook*

### Seguridad personal

- Use siempre anteojos de seguridad y protección auditiva en un entorno industrial.
- Utilice una máscara protectora cuando trabaje cerca de aserrín.
- Utilice ropa adecuada y equipo de protección personal apropiado (por ejemplo, anteojos de seguridad y protección auditiva.) No use ropa suelta ni joyas. Si tiene el cabello largo, áteselo para atrás.
- Proceda con precaución cuando levante piezas o materiales pesados.

## **Instalación del equipo**

- Siga las instrucciones de instalación al pie de la letra.

## **Procedimientos de Bloqueo/Etiquetado**

- Antes de realizar el mantenimiento de los sistemas neumáticos o hidráulicos, purgue las líneas para eliminar la presión.
- Bloquee y etiquete todos los sistemas energizados antes de realizar tareas de mantenimiento en ellos. Refiérase a la sección *Pautas de bloqueo/etiquetado* en la página xii.

## **Cómo mantener un entorno seguro**

- Mantenga alejados a los niños. Todos los visitantes deben mantenerse a una distancia segura del área de trabajo. Los riesgos pueden no ser evidentes a las personas no familiarizadas con la máquina.
- Mantenga las áreas de trabajo bien iluminadas.
- Mantenga el área de trabajo limpia y libre de cualquier riesgo de tropiezo o resbalamiento.
- No utilice el equipo en lugares húmedos o mojados y no lo exponga a la lluvia o a la nieve.

## **Uso y mantenimiento del equipo**

- Asegúrese de que no haya personas, herramientas y objetos extraños en las zonas restringidas antes de utilizar este equipo. Las zonas restringidas se indican en la página xvii.
- Realice pruebas de seguridad para verificar que todos los frenos de emergencia funcionen adecuadamente antes de utilizar el equipo por primera vez, después de realizar cualquier tarea de mantenimiento y según la frecuencia de mantenimiento establecida.
- En caso de que la máquina no funcione correctamente, deténgala inmediatamente utilizando un freno de emergencia e informe el problema a un supervisor.
- No deje nunca la máquina encendida si no está junto a ella. ¡Apáguela!. No abandone la máquina hasta que todas las piezas se detengan completamente y hasta que se haya apagado la alimentación eléctrica.
- Verifique periódicamente que no haya piezas gastadas o dañadas. Repárelas o cámbielas inmediatamente.
- Mantenga los sistemas hidráulicos, neumáticos y eléctricos en buen funcionamiento en todo momento. Repare las fugas y las conexiones sueltas inmediatamente. No exceda nunca la presión ni potencia eléctrica recomendadas.

- Verifique que todos los dispositivos de seguridad estén en buen funcionamiento al comienzo de cada turno. Todos los dispositivos protectores y de seguridad deben estar en su lugar antes y durante el uso de la máquina. No desconecte ni evite nunca ningún dispositivo de seguridad ni interbloqueo eléctrico.
- Inspeccione periódicamente la calidad del producto terminado.

### **Seguridad eléctrica**

- No utilice líquidos en el interior de los gabinetes eléctricos.
- Cuando utilice disolventes sobre o alrededor de la máquina, desconecte la alimentación para eliminar las probabilidades de chispas, que pueden producir una explosión o incendio. Use un respirador aprobado para el uso con disolventes. Use ropa protectora, guantes y anteojos de seguridad.

## Bloqueo/Etiquetado

### Pautas de bloqueo/etiquetado

Deben cumplir con todas las pautas de bloqueo/etiquetado conforme a la norma OSHA 29 CFR 1910.147. El programa de control de energía de la compañía debe incluir un procedimiento específico. El objetivo de este manual no es reemplazar el procedimiento de desenergización o bloqueo/etiquetado requerido por la OSHA, sino proporcionar pautas orientativas generales.

El término "bloqueo", según se utiliza en este manual, se refiere a la colocación de un dispositivo de bloqueo en las fuentes de energía para asegurar que el dispositivo aislador de energía y el equipo controlado por éste no puedan reenergizarse o utilizarse hasta que se retire dicho dispositivo.

Las fotos de la página siguiente muestran los lugares en los que se encuentran los interruptores de desconexión eléctrica de esta máquina.



- Las fuentes de energía incluyen energía eléctrica, mecánica, hidráulica, neumática, química, térmica y otras.
- En el caso de fuentes de energía eléctrica, la alimentación principal y la alimentación de control a la maquinaria deben apagarse y bloquearse físicamente en la posición "off" (apagado).
- Por lo general, como dispositivo de bloqueo se utiliza un candado con llave.
- Si hay más de una persona trabajando en una zona restringida, utilice un dispositivo de bloqueo grupal que permita a cada persona utilizar un candado que sólo pueda ser retirado por la persona que realiza el mantenimiento.

"Etiquetado" significa que debe colocarse una advertencia fácil de ver en un dispositivo aislador de energía que indique que el equipo no debe utilizarse.

## Procedimientos de bloqueo/etiquetado eléctricos

### Cuando trabaja en una máquina fuera del gabinete eléctrico principal de la máquina



Si trabaja en la línea de transmisión eléctrica a la máquina, siga el procedimiento de la página xv.

Antes de realizar el mantenimiento de cualquier máquina con alimentación eléctrica, bloquee y etiquete la máquina de forma adecuada. Cuando trabaje en una máquina fuera del gabinete eléctrico principal de la máquina, salvo en el caso de trabajos en la línea de transmisión eléctrica a la máquina, siga los procedimientos de bloqueo/etiquetado aprobados por la compañía, los cuales deberían incluir, entre otros, los pasos aquí indicados.

1. Coloque un freno de emergencia sobre la máquina.
2. Coloque el mango del interruptor con fusibles en la posición "apagado/apagada".  
Vea la figura 2-1.

<b>WARNING</b>	
	<p><b>RIESGO DE ELECTROCUCIÓN.</b></p> <p><b>Cuando el interruptor con fusibles está apagado, sigue habiendo energía dentro del gabinete del interruptor. ¡Apague siempre la alimentación en la fuente de alimentación del edificio antes de abrir este gabinete eléctrico!</b></p>

3. Coloque un candado y una etiqueta que cumplan con los requisitos de bloqueo/etiquetado de la OSHA.
4. Trabe o desenergice todos los componente neumáticos, componentes hidráulicos y otras piezas que tengan alimentación directa o almacenada.



**Figura 6-1: Bloqueo/etiquetado en el gabinete eléctrico principal**

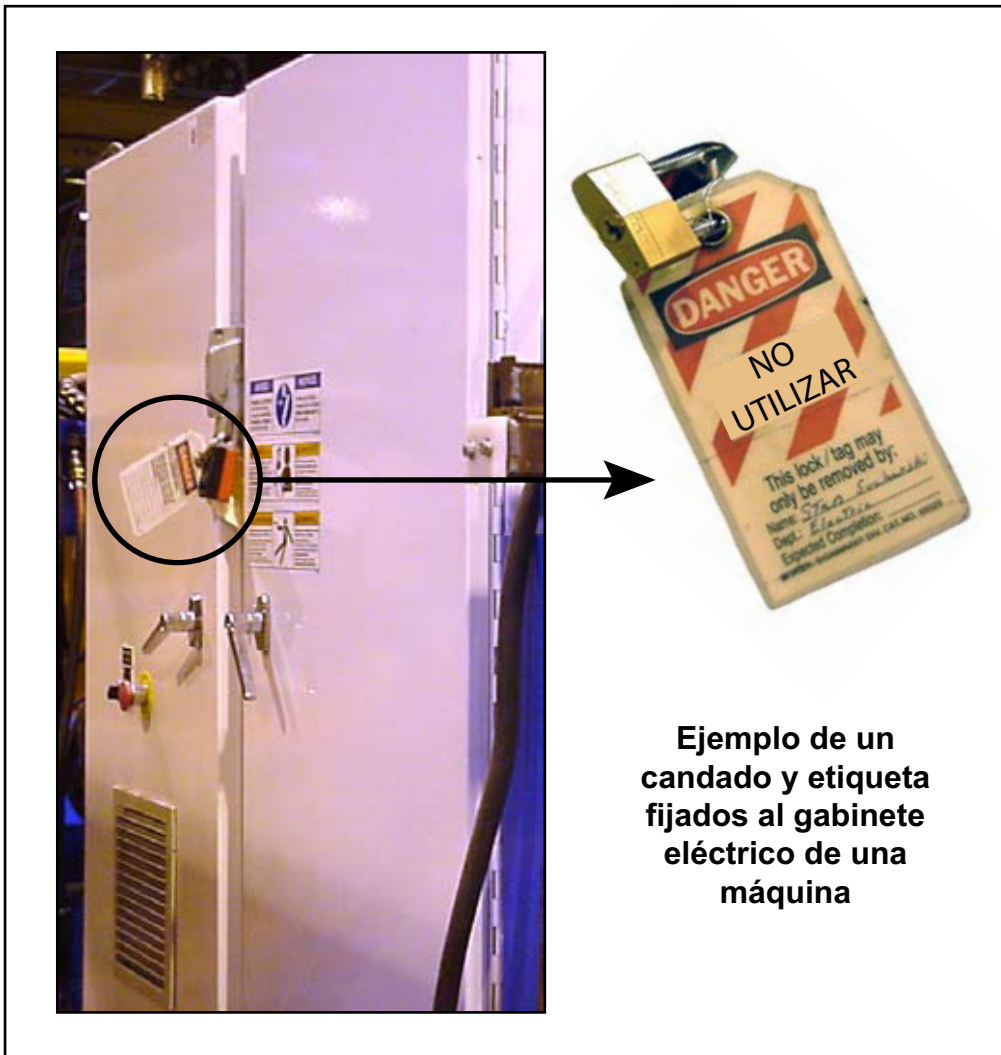

### **Cuando trabaje en una máquina dentro del gabinete eléctrico principal de la máquina o en la línea de transmisión eléctrica a la máquina**

Antes de abrir el gabinete eléctrico principal o intentar reparar o reemplazar una línea de transmisión eléctrica a la máquina, bloquee y etiqueta la máquina en forma adecuada. Siga los procedimientos de bloqueo/etiquetado aprobados por la compañía, los cuales deberían incluir, entre otros, los pasos aquí indicados.

1. Coloque un freno de emergencia sobre la máquina.
2. Apague la alimentación a la máquina en la fuente de alimentación, que, por lo general, es un panel de entrada de suministro eléctrico que se encuentra en una pared de las instalaciones. En la figura 2-2 se muestra un ejemplo de panel de fuente de alimentación bloqueado.
3. Coloque un candado y una etiqueta que cumplan con los requisitos de bloqueo/etiquetado de la OSHA.
4. Abra la puerta del gabinete al que necesita acceder y usando un multímetro verifique que la alimentación esté apagada.

**Figura 6-2: Bloqueo/Etiquetado del panel de fuente de alimentación**



## **Solución de problemas con una máquina energizada**

Sólo un electricista calificado que utilice el equipo de protección personal y siga los procedimientos recomendados en la norma NFPA 70E debe intentar realizar tareas de reparación o mantenimiento en un área o componente energizados de la máquina o en su proximidad.

Cada vez que se realizan tareas de mantenimiento mientras el equipo está eléctricamente energizado, existe un riesgo potencial de formación de un arco eléctrico. Consulte en la norma NFPA 70E el equipo de protección personal requerido para trabajar con componentes eléctricamente energizados. Los componentes neumáticos e hidráulicos pueden moverse de manera imprevista si no se desenergizan. Trabe físicamente cualquier componente que pueda moverse cuando deba trabajar en ellos o en su proximidad.

## Zonas restringida

<b>DANGER</b>	
	<p>Manténgase afuera de la zona restringida cuando el equipo esté en uso. Pueden producirse lesiones graves o incluso la muerte si el personal está en la zona restringida.</p>

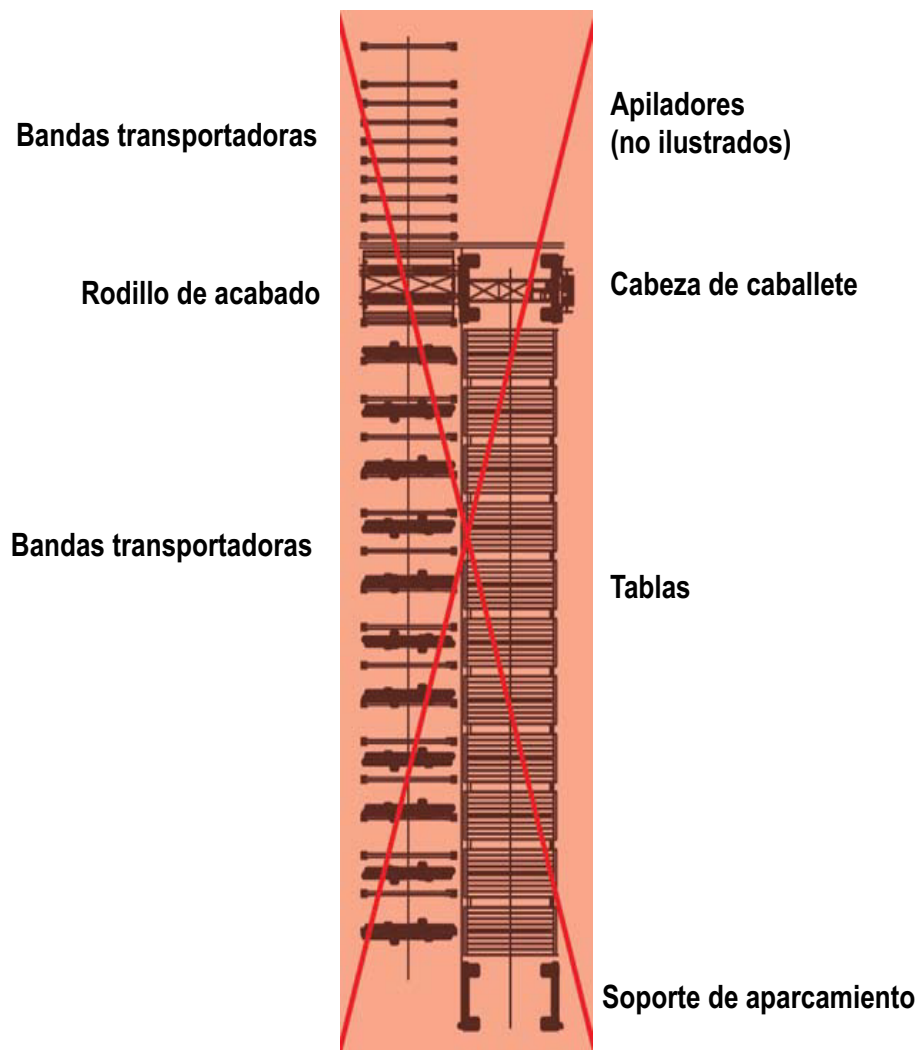

### Purpose of Chapter

This chapter introduces you to this manual and provides an overview of your equipment and the means to identify it.

## Introduction to the Equipment

### Purpose of the Equipment

The Finish Roller press is designed to finish the connector plate embedment process in a wooden truss fabrication system.

### Description of the Equipment

The Finish Roller press is a 24-in. diameter roller press with manual controls that, in the second stage of a gantry truss fabrication system, completes the connector plate embedment process. The gantry system fabricates wooden trusses with a two-stage connector plate embedment process. In the first stage, a traveling gantry head performs the initial plate embedment by seating the connector plates into the wood fiber.

Figure 1-1 shows an overall view of the equipment. Refer to the *Maintenance* chapter for more detailed graphics.

**Figure 1-1: Finish Roller Press**

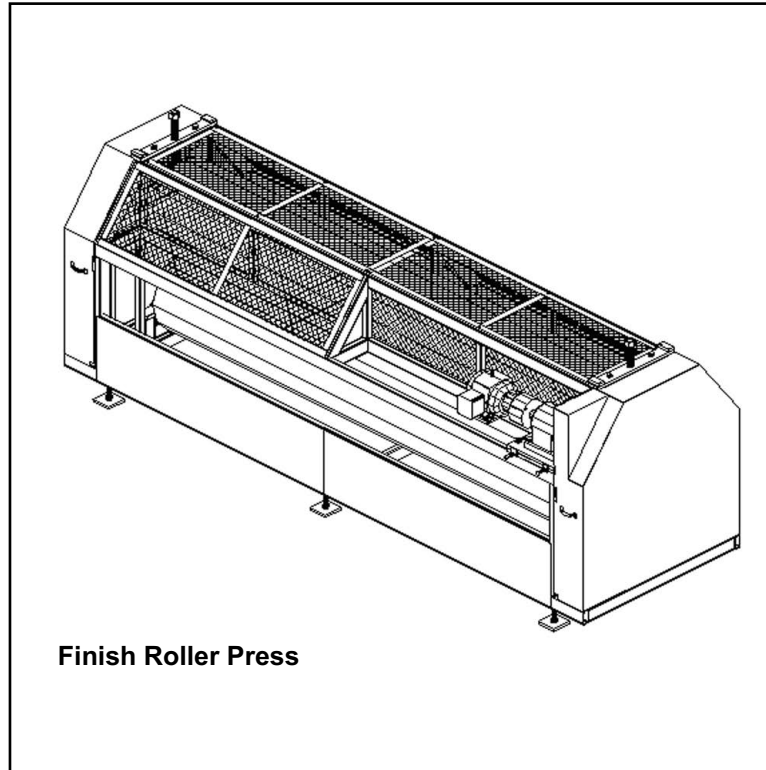

## Contacting MiTek

For technical assistance or to order parts, contact the Machinery Division Customer Service Department using one of the methods listed in Figure 1-2.

**Figure 1-2: Contacting MiTek**

**MiTek Machinery Division**  
Customer Service Department  
301 Fountain Lakes Industrial Drive  
St. Charles, MO 63301

**Parts Orders (with part number)**  
E-mail: [mitekparts@mii.com](mailto:mitekparts@mii.com)

**Technical Assistance**  
Phone: 800-523-3380  
Fax: 636-328-9218  
[machinerysupport@mii.com](mailto:machinerysupport@mii.com)

**Web Site**  
[www.mitek-us.com](http://www.mitek-us.com)



## General Specifications

**Table 1-1: General Specifications**

<b>General</b>	
Speed (press capacity)	100' per minute (standard) 150' per minute (optional)
Direction	Forward/reverse
Roller length	14' (16' also available)
Height adjustment	0" to 6"
Roller diameter	24" nominal (outside)
Roller wall thickness	3/4" nominal
Baffles per roller	4 (completely welded)
Throat opening	14'-4" wide
Shaft diameter	4" outside diameter
Bearing size	3-7/16" heavy duty
Weight	14,000 lb
<b>Motor - Electric</b>	
Horsepower rating	10 hp
Motor speed	1,750 rpm
Starting switch	Pushbutton
Voltage	208/230/460 VAC
Amperage	32.2/28.0/14.0
Cycles	60
Phase	3
Frame	215TC
Clutch	Automatic centrifugal (soft-start)
Brake	Electrical magnetic disk (industrial)
Controls	Pushbutton station
Chain drive	#100 chain

### NOTICE

**Standard motors are furnished unless otherwise specified by customer. Nonstandard motors are subject to additional cost.**

**Customers to supply disconnects (see Table 1-1 on page ix for amperage requirements).**

## Truss Terminology

**Table 1-2: Truss Terminology**

Length Types	Height Types	
Overall length	H1	Board height
Centerline length	H2	Centerline height
Top length	H3	Centerline height
Bottom length	H4	Centerline height

**Figure 1-3: Terminology Diagram**

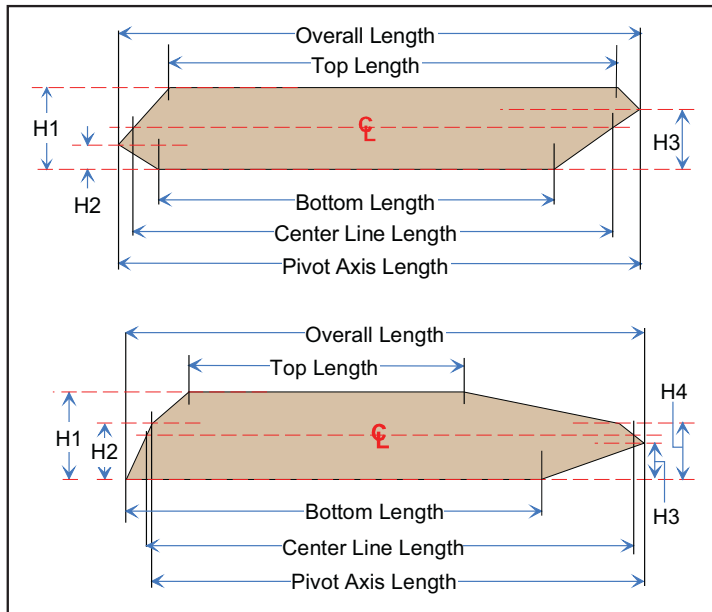



**Figure 1-4: Parts of a Truss**

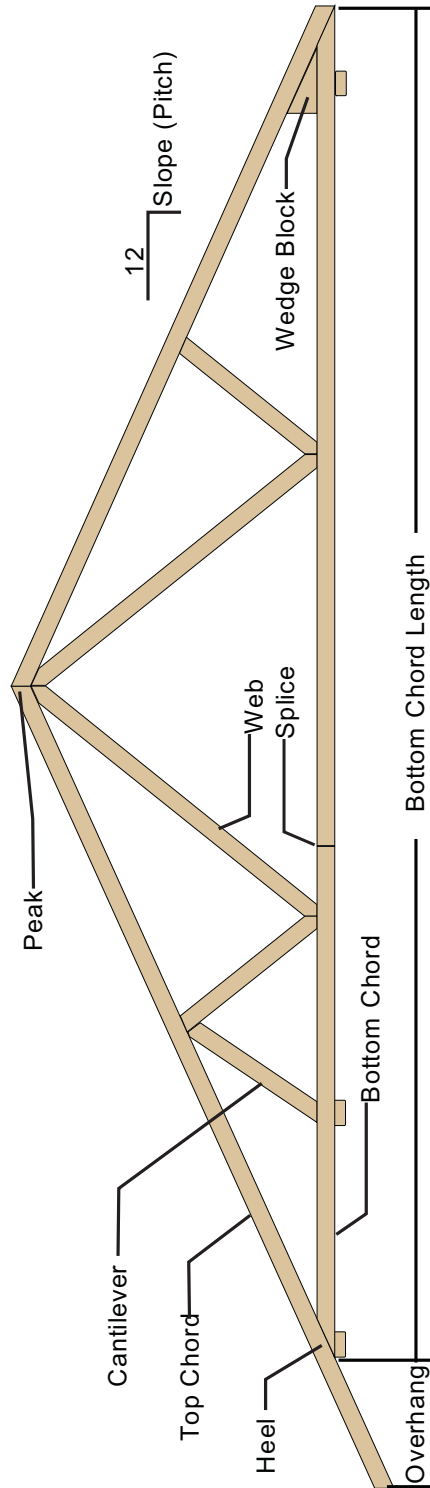

### Purpose of Chapter

This chapter covers what you must consider or complete before this equipment can be installed.

## MiTek's Responsibilities

### Prior to Installation

Prior to the installation date, MiTek will provide a Prior to Installation package that:

- Outlines this chapter and requests your signature of agreement.
- Gives dates to expect shipment, delivery, and installation.
- Explains the number of people required to help with installation.
- Provides guidelines on providing an electrician, welder, and other specialists.
- Describes payment information.

## Customer's Responsibilities

Before the installation of your equipment, the items and procedures in this chapter must be arranged, purchased, or assembled. Table 2-1 provides an overview of these items. Each topic listed in the table is explained in detail in the text following the table.

If these requirements are not satisfied before the scheduled installation date, it may be necessary to reschedule the installation. Any additional cost may be the customer's responsibility.

**Table 2-1: Summary of the Customer's Responsibility**

Space Requirements	This equipment requires enough space to allow for the machine dimensions listed in your layout, plus additional working space for operation and maintenance. Space should have adequate lighting.
Location Requirements	Concrete, a minimum of 6 in. thick 5,000 psi, is required under the weight of the stand-alone conveyors and Finish Roller. The equipment discussed in this manual must be used in dry conditions under a roofed area.
Electrical Requirements	The standard electrical requirements are shown in Table 2-2. Contact your MiTek representative immediately if custom power specifications need to be arranged.
Shipping Weights	See Table 2-3.
Customer-Supplied Items Required	The customer is responsible for having the supplies listed in Table 2-4 available at the time of installation.

### Space for the Equipment

It is the customer's responsibility to provide adequate space for the installation, operation, and protection of the equipment. The Finish Roller is approximately 8 ft wide and 17 ft long. Additional space is required for operation, maintenance, and optional equipment.

### Space for Operation and Maintenance

Additional space must be allocated for operation and maintenance. Space should allow for safe operation, freedom of movement, storage space, and free flow of raw and finished materials.

### Determining the Space Needed for Your System

MiTek can provide help to the customer in plant layout and space utilization, if requested.

## Location Requirements

### Floor Structure

A level and structurally sound concrete slab must be provided for the installation of the equipment (see Figure 3.1). This slab should be designed and installed in accordance with local building code requirements and, if required, under supervision of a professional engineer. Concrete should be a minimum of 6 in. thick. Five thousand (5,000) psi concrete is recommended. Refer to your layout drawing.

### Environment

The equipment must be used in dry conditions under a roofed area.

Lighting should be adequate for safe operation and maintenance.

## Electrical Requirements

The standard electrical requirements are shown in Table 2-2. Each machine can be designed for any of the incoming voltages listed.

The power supply must have a fused disconnect switch, separate from the disconnect switch on the machine. The power supply line must reach the disconnect enclosure on the machine.

You must indicate what voltage is available at the machine’s proposed location when placing the order. This information must be correct. Depending on the voltage available, revisions to the electrical system or a transformer may be necessary..

**Table 2-2: Electrical Requirements Prior to Installation**

Electrical Requirements	
Voltage	208/230/460 VAC
FLA Plus Control Amperage	40/28.2/14.1 amps
Equipment Disconnect Protection	45/40/20 amps
Cycles (Frequency)	60 Hz
Phases	3

<b>WARNING</b>	
	<p><b>ELECTROCUTION HAZARD.</b></p> <p><b>All electrical work must be done by a qualified electrician and conform to all electrical codes.</b></p>

Machines should be installed in a well-lit area for proper operation, periodic maintenance and safety.

The Finish Roller press is pre-wired and all wires terminate at an electrical enclosure on the machine.

Due to electrical code differences throughout the country, the customer will supply the conduit and related material to make the final electrical connections between the building power supply and the Finish Roller press.

A disconnect for the Finish Roller press control panel is not included. The disconnect size is dependent on the voltage and will vary from system to system. The amps drawn by the components determines the proper disconnect size. Your local electrician will need to verify the amp requirement and disconnect size (refer to Table 1-1 on page ix for motor horsepower and amp draw). Components are rated for 230V and 460V as “standard” and 208V as optional. The Finish Roller press components and panel will be supplied to match each situation.

## Mechanical Requirements

The Finish Roller press will be supplied complete with all mechanical components. The Finish Roller press is an independent stand-alone unit that will be set in place.

## Shipping Information

When the equipment arrives, you must have the proper transport and lifting equipment available to remove it from the truck and place it in your facility. Table 2-3 lists the weight of the individual components of a typical system.

<b>DANGER</b>	
	<p><b>CRUSH HAZARD.</b></p> <p>Transport and lifting equipment such as forklifts and cranes must be designed and rated for the load and application. The weight of each major component is given in Table 2-3.</p> <p>Inadequate transport equipment may result in property damage, personal injury, or death.</p>

**Table 2-3: Shipping Information**

Contents of Shipment	Approximate Weight
Finish Roller, 14'	13,000 lb
Finish Roller, 16'	15,000 lb

## Customer-Supplied Parts

The customer must supply the parts shown in Table 2-4. Some must be installed before installation occurs and some must be available for use at the time of installation.

**Table 2-4: Customer-Supplied Parts**

Item	Description
Electrical Equipment	All electrical requirements to provide power to the disconnect enclosure on the Finish Roller are the customer's responsibility
Transport Equipment	A heavy-duty forklift or truck wrecker is required to move the equipment during unloading and placement of the machine; chains and spreader bars may also be required  All transport and lifting equipment must meet the requirements given in the <i>Shipping Information</i> section
General Tools	8-ft level 1-1/2-in. wrench

## Training Provided

In the case where MiTek is overseeing the installation of your equipment, the MiTek representative will ensure that your operators and maintenance personnel understand how to operate and maintain this equipment. They will explain warranty information and ensure that the equipment manual is present.

### Purpose of Chapter

This chapter describes the entire installation process in detail. The instructions assume that the prior-to-installation requirements are satisfied.

## Responsibilities During Installation

MiTek can provide installation supervision to ensure that the system is installed properly and operates correctly. We can also provide operating and maintenance training at the time the equipment is installed. The customer is responsible for providing all labor and equipment needed to complete the installation. These requirements are explained in the *Prior to Installation* chapter.



All customer responsibilities before and during installation are described in the *Prior to Installation* chapter.

## Delivery

### Checking for Damage

All shipments from MiTek are covered with tarps. When your shipment arrives, check to see that the tarps are in place. Displaced tarps may indicate a potential problem.

After removing the tarps, inspect the shipment for water/moisture, debris, and damage. Report any findings as required by the transport company. Document any findings by taking photographs or a video. Note any and all damage to the equipment on the bill of lading to ensure proper documentation for insurance claims. Without this note, any damage in transit is the responsibility of the customer to repair.

Notify MiTek Machinery Division Customer Service of any unacceptable findings are discovered during the receipt inspection. Although your findings may not appear to be a problem, they may cause premature failure of components, poor performance, or erratic performance.

## Unloading



**Refer to...**  
Table 1-6 on page 7 for the weight of each component

Refer to the *Prior to Installation* chapter for information regarding preparing for the delivery.

Even if a MiTek representative is present, it is the customer's responsibility to provide equipment and labor for unloading, placement, and wiring of the equipment.

Exercise extreme caution to avoid damage or misalignment during unloading. Do not apply pressure on any moving parts or fittings. Weight should be supported by the bottom of the Finish Roller press frame. An 8-ton forklift will be required to move the Finish Roller press.

WARNING	
	<p><b>CRUSH HAZARD.</b></p> <p>Failure to lift the equipment in the prescribed manner may cause serious injury, including death, or equipment damage.</p> <p>Personnel not involved in the off-loading from the truck shall remain clear of the area.</p> <p>Transport and lifting equipment such as forklifts and cranes must be designed and rated for the load and application.</p>

## Unpacking

After successful unloading, remove the protective crating material from the pallets. Detach and set aside all loose parts. Move the equipment to the desired location using a forklift or crane appropriate to the weight of each unit.



## Equipment Layout

Refer to your own layout during installation. Your MiTek representative can provide your layout to you before the equipment is installed.

## Assembly

Installation of the Finish Roller press can be supervised by a MiTek representative. He can supervise layout, dimensioning, lining, leveling, connecting, assembling, and complete installation of the equipment. He can make pre-operational checks and final adjustments as needed, and instruct personnel in the proper operation and maintenance of the equipment.

MiTek recognizes that the installation can be disruptive to the production schedule. For this reason, we request the most efficient people to assist with the installation. These people can complete their work quickly, efficiently, and with a high degree of quality. The end result is a quality system that will operate at maximum efficiency.

1. Move the Finish Roller press in place using a forklift and supporting the machine by the bottom of the frame. The machine is heavier on the end with the drive, and the forklift operator must position the forklift to compensate for the offset load. Two forklifts, one at each end of the machine, can be used if a single lift is not large enough.

<b>WARNING</b>	
	<p><b>CRUSH HAZARD.</b></p> <p><b>Do not drop the Finish Roller press, and do not lift the machine by the rollers. Failure to follow approved lifting techniques may result in severe personal injury or death.</b></p>

2. Place the machine in the required location.
3. Rotate the six threaded leveling feet up or down to set the height of the Finish Roller press; the top of the bottom roller should be in the same plane as the top of the conveyor rollers. This setting varies, but standard side-eject systems are approximately 31" and standard end-eject systems are approximately 37". (You will have to support the weight of the machine with a forklift or hydraulic jack before you will be able to rotate the feet.)
4. Shim both ends of the machine, under the 4 x 2 tube frame, as required. Use 2 x 6 or 2 x 8 material 5-1/2' long to fill in the space. This will reduce the vibration created when starting, stopping, and pressing plates.
5. Wire the machine into the building's electrical system. An electrician must make the connections between the building and the Finish Roller press.

## Forklift

One heavy-duty forklift of not less than 8-ton capacity is required. An operator will be required for unloading and moving the Finish Roller press to the installation site.

If there are any questions, please contact your MiTek Technical Representative (Customer Service).

## Electrical System

<b>WARNING</b>	
	<p><b>ELECTRICAL HAZARD!</b></p> <p><b>All electrical work must be performed by a qualified electrician.</b></p> <p><b>Follow approved lockout/tagout procedures (OSHA 29 CFR 1910.147).</b></p>

## Checking Existing Wiring

Heavy gauge wire can work loose during shipping and handling. Before power is connected to the machine, conduct a pull test on all pre-wired connections inside the electrical enclosures.

## Connecting Power to the Equipment

All electrical work is the customer's responsibility and must be performed by a qualified electrician. The machine design addresses electrical components starting with the disconnect enclosure. Installation and maintenance of all electrical requirements up to the disconnect enclosure are the responsibility of the customer. Your MiTek representative can provide guidance regarding when the electrical will need to be available during the installation.

<b>CAUTION</b>	
<p><b>Upon delivery of the machine, do not start without checking oil level in the gearbox.</b></p> <p><b>Failure to maintain the proper oil level may result in damage to the machine.</b></p>	

## ***Installation Checklist***

- Check for damage
- Unload the Finish Roller
- Unpack the Finish Roller
- Place the machine in the correct location
- Level the machine
- Connect electrical power

<b>WARNING</b>	
	<p><b>ELECTROCUTION AND CRUSH HAZARDS!</b></p> <p><b>Do not attempt to start the system without a MiTek representative present!</b></p> <p><b>Serious injury and/or equipment damage may result.</b></p>

### Purpose of Chapter

This chapter describes the operating mechanisms on this equipment and the procedure to operate it in most circumstances.

## Safety Hazards During Operation

WARNING	
	<p><b>ELECTROCUTION, CRUSH, AND CUT HAZARDS!</b></p> <p>Read this section <b>AND</b> the safety section in the preliminary pages before operating or maintaining this equipment.</p> <p>Do not operate this machine until you have a thorough understanding of all controls, safety devices, E-stops, and operating procedures outlined in this manual.</p> <p>Read and observe all warnings. Failure to do so may result in economic loss, property damage, and/or personal injury.</p> <p>This manual must always be available to personnel operating and maintaining this equipment.</p>

WARNING	
	<p><b>ELECTRICAL HAZARD!</b></p> <p>All electrical work must be performed by a qualified electrician.</p> <p>Follow approved lockout/tagout procedures (OSHA 29 CFR 1910.147).</p>

<b>WARNING</b>	
	<p><b>CRUSH AND CUT HAZARD</b></p> <p>Guards must always be in place during operation to avoid serious injury and possibly death.</p> <p>Always replace guards after maintenance is complete and before removing the lockout/tagout device.</p>

<b>WARNING</b>	
	<p><b>CRUSH AND CUT HAZARD.</b></p> <p>Before turning on the equipment, make sure that all personnel and equipment are clear.</p> <p>Never stand in an aisle while the machine is in operation.</p>

## Things to Know Before You Begin

### Stopping the Machine

Note the type and location of all stopping methods before operating this equipment.

#### Emergency Stop (E-Stop) Pushbuttons

A typical E-stop pushbutton is shown in Figure 5-1.

Push the red emergency stop (E-stop) button located on the outside of the electrical enclosure to cease power transmitting to the control circuit. To release the E-stop, pull straight up on the pushbutton. It will return to its extended position and the machine will operate again.

Figure 5-1: E-Stop Pushbutton



#### Disconnect Switch

The disconnect switch controls the power supplied from that switch to the rest of the machine. Turning the disconnect handle on the outside of the electrical enclosure to the ON position supplies electrical power to the entire machine. To remove power to the machine, turn the disconnect handle to the OFF position. The disconnect handle should always be turned off when the machine is not in use.

<b>WARNING</b>	
	<p><b>ELECTRICAL HAZARD.</b></p> <p><b>When the disconnect switch is OFF, there is still live power up to the disconnect switch's enclosure. Always turn off power at the main power source before opening this enclosure!</b></p>

#### Operator Push Bars

The Finish Roller has two operator push bars. To stop the motion of the machine, push the push bar up toward the machine.

### Starting the Machine

Refer to the the *Operating Procedure* section on page xi section for the operating procedure.

## Operator Control Interface

Each Finish Roller press has an E-STOP pushbutton and FORWARD and REVERSE pushbuttons located on the outside of the electrical enclosure and two operator push bars.

**Figure 5-2: Overview of Control Mechanisms**

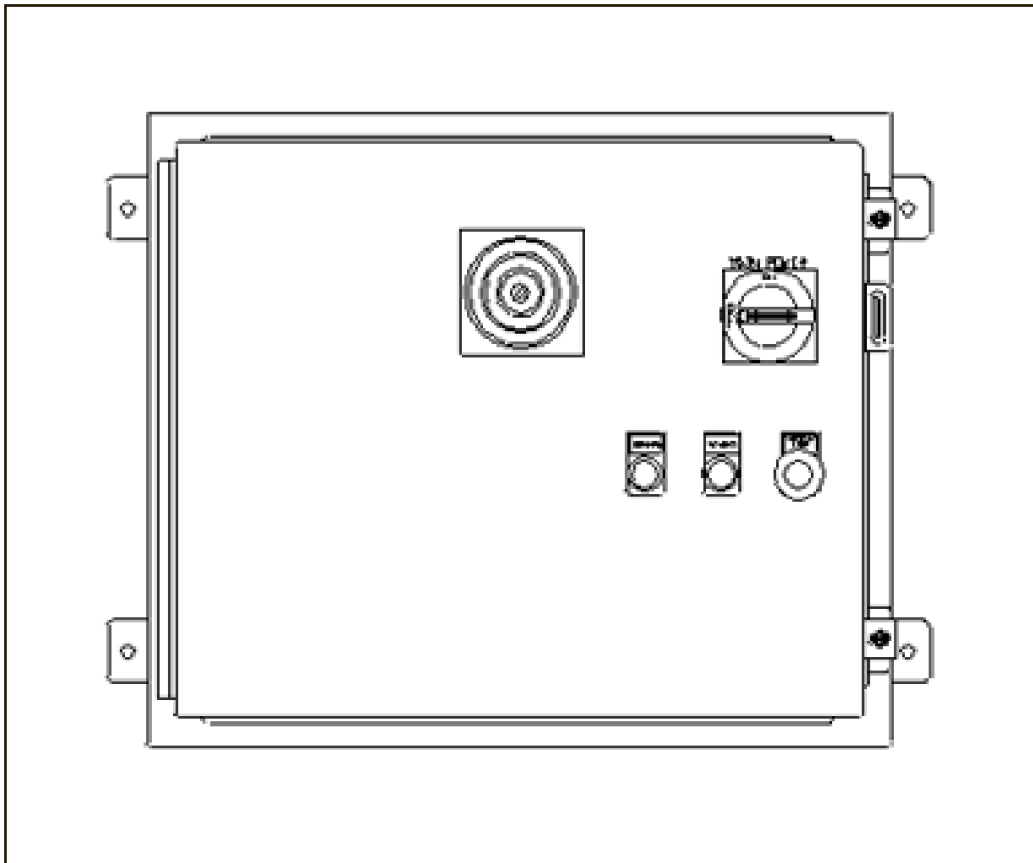

**Table 5-1: Functions of Control Mechanisms**

Control Mechanisms	Function
Forward pushbutton	Enables the Finish Roller to operate in the forward direction
Reverse pushbutton	Enables the Finish Roller to operate in the reverse direction
Emergency stop pushbutton	Stops the motion of all moving parts on the Finish Roller

## Operating Procedure

<b>WARNING</b>	
	<p><b>PERSONAL INJURY HAZARD.</b></p> <p>Never operate the Finish Roller press without all guards in place and operational.</p>

<b>WARNING</b>	
	<p><b>PERSONAL INJURY HAZARD.</b></p> <p>Never remove or paint over warning labels. If labels become deteriorated or damaged, request new ones through our Customer Service Department.</p>

<b>WARNING</b>	
	<p><b>ELECTRICAL, CRUSH AND CHEMICAL HAZARDS.</b></p> <p>Only qualified personnel should attempt to perform installation, repair, and/or maintenance. Compliance with minimum recommendations outlined throughout this manual is essential.</p>

### Procedure Under Normal Conditions

1. Inspect the area around the Finish Roller press prior to turning it on.
2. Turn the disconnect handle to the ON (vertical) position.
3. Check the location of both operator push bars. They should be in the extended position, making the E-stop limit switches. If they are not, research the cause and correct it before extending the push bars.
4. Press the FORWARD or REVERSE pushbutton to run the roller in the required direction.



5. Press the E-stop pushbutton to stop the machine.

### NOTICE

Press the E-stop pushbutton or either operator push bar to stop the Finish Roller press in an emergency situation.

### NOTICE

Standard operating procedure is to turn the Finish Roller press on at the beginning of the shift, off at lunch, back on after lunch, and off at the end of the shift. It is better for the machine components to run continuously than to turn on and off continually.

### NOTICE

When an E-stop is activated, it will stop all motion by removing power to the motor. This is accomplished by disengaging the master control relay.

## Restart Procedure

Reactivate any E-stops. If the press stalled because a barrier depressed a push bar, remove the barrier. Push the FORWARD or REVERSE button to start the machine.

### Purpose of Chapter

This chapter provides step-by-step instructions as well as information to help you understand how your equipment works to enable you to make repairs and perform preventive maintenance.

## Introduction to Maintaining Your Equipment

This manual contains sufficient information for proper operation and maintenance under most conditions. Certain operating environments may necessitate preventive maintenance at more frequent intervals. Because consistent preventive maintenance is so important for keeping mechanical equipment in good operating condition, MiTek recommends that you stock certain replacement parts to minimize downtime.

Review the table of contents and utilize the index to locate the information you need. The following appendices will also assist in maintaining and repairing your equipment:

- Troubleshooting
- Parts List
- Maintenance Checklists
- Drawing Set

Read the *Performing Maintenance Safely* section before beginning maintenance on this equipment.

## Performing Maintenance Safely

Read the safety pages in the preliminary pages section and adhere to all rules and guidelines. This section provides additional safety information specific to maintenance topics.

### Before Operating This Equipment

Adhere to these warnings before operating this equipment:

<b>WARNING</b>	
	<p><b>ELECTROCUTION, CRUSH, AND CHEMICAL HAZARDS!</b></p> <p>Read this section <b>AND</b> the safety section in the preliminary pages before operating or maintaining this equipment.</p> <p>Do not operate this machine until you have a thorough understanding of all controls, safety devices, E-stops, and operating procedures outlined in this manual.</p> <p>Read and observe all warnings. Failure to do so may result in economic loss, property damage, and/or personal injury.</p> <p>This manual must always be available to personnel operating and maintaining this equipment.</p>

### Lockout/Tagout



The lock and tag symbol shown here indicates that proper lockout/tagout procedures must be used prior to starting the procedure where the symbol occurs.

<b>WARNING</b>	
	<p><b>ELECTROCUTION HAZARD.</b></p> <p>Always turn the power off by activating an E-stop when the equipment is not in operation.</p> <p>Always verify that all power to the machine has been turned off and follow approved lockout/tagout safety procedures (OSHA 29 CFR 1910.147) before performing any maintenance on this equipment.</p> <p>If it is absolutely necessary to troubleshoot an energized machine, follow NFPA 70E for proper procedures and personal protective equipment.</p>

## Making Adjustments to the Machine

Be careful when making mechanical adjustments. Untrained personnel may damage the machine or cause harm to themselves and others.

### **CAUTION**

**Failure to follow the step-by-step procedure may result in incorrect adjustment of this machine and could cause blade collisions and incorrect cuts. Only trained personnel should make mechanical adjustments to this machine.**

**Use the exact replacement parts that are specified by MiTek.**

## Wearing Personal Protective Equipment

Follow OSHA guidelines to utilize the proper personal protective equipment (PPE) while performing maintenance. The most common include eye protection, hearing protection, dust masks while blowing off sawdust, gloves while working with solvents, and fire retardant clothing when troubleshooting an energized machine.

## Conducting Safety Tests

Ensure safety devices are always operating properly.

### **WARNING**



#### **CRUSH HAZARD.**

**Always test the E-stops before operating the equipment at the initial startup, after performing any maintenance, and in accordance with the maintenance schedule.**

## Overview Graphics

Figure 6-1: Grease Points

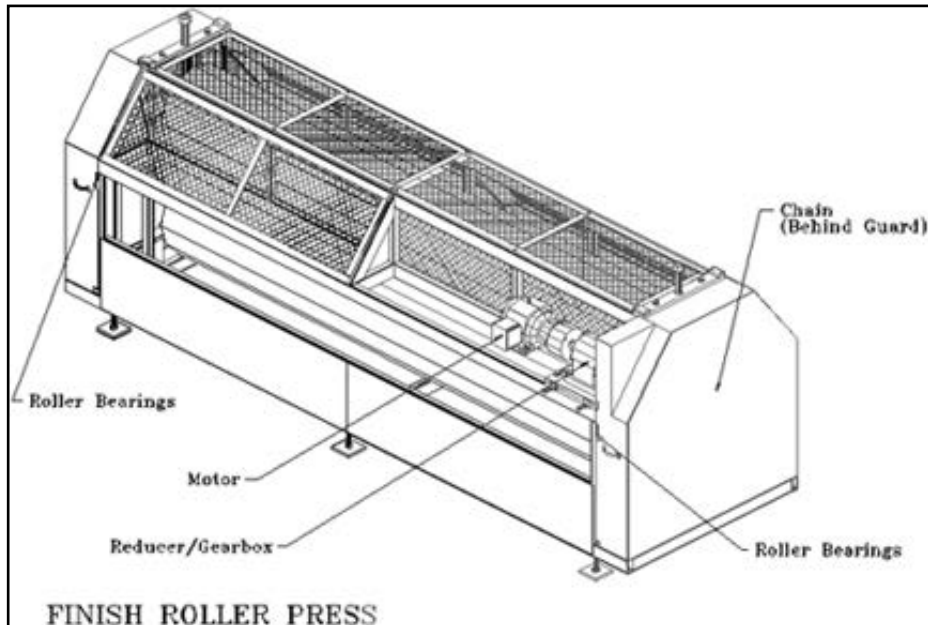

## Adjustments

<b>WARNING</b>	
	<p><b>PERSONAL INJURY HAZARD.</b></p> <p>To prevent unexpected machine operation or possible electrocution, always turn off and lockout the power source before making any machine adjustments or repairs.</p>



### Adjusting the Speed Reducer/Gearbox Chain

1. Check the #100 drive chain tension. Drive chain play should be less than 1/2 inch (1/4-inch movement to both sides of center).
2. Check the drive sprocket alignment; the sprockets should be in the same plane. If they are not, see *Aligning/Adjusting the Sprocket*.
3. If gearbox chain tension is required:

- a) Loosen the reducer/gearbox mounting plate bolts (4) and the motor mounting plate bolts (4).
- b) Tighten the adjustment bolts (jack screws) on the reducer mounting plate to slide the entire drive assembly outwards until the drive chain play is 1/2 inch (1/4 movement to both sides of center). **It is critical to keep the drive centerline parallel with the roller centerline.**
- c) Tighten the reducer/gearbox and motor mounting plate bolts.

## Aligning/Adjusting the Sprocket



### #100 Sprocket on the Roller

This sprocket must be in the same plane as the drive sprocket on the gearbox. Loosen the set screws on the sprocket and move the sprocket in or out as required. When in the correct location, tighten the set screws.



### #100 Sprocket on the Reducer/Gearbox

Use a straight edge to align the two sprockets. If the QD bushing/sprocket (on the gearbox) requires moving, see the *Adjusting the QD Sprocket* section on page xi.



### #100 Sprocket on the Jack Shaft

Use a straight edge to align the sprocket with the #100 sprocket on the roller. If the bushing/sprocket requires moving, see *Adjusting the QD Sprocket*.

## Adjusting the QD Sprocket

1. Remove all the cap screws in the bushing.
2. Install the cap screws into the threaded jack holes of the bushing.
3. Tighten the jack screws alternately and evenly, beginning with screw farthest from bushing saw slot, until bushing grip is released. Slide unit off shaft.

### CAUTION

**Tighten the jack screws carefully. Excessive screw torque may cause damage to either bushing and/or product. Uneven pressure on jack screws may also damage the bushing flange, making removal difficult.**



## Installing the QD Sprocket

1. Clean the shaft, product bore, bushing tapered surface, and bushing bore of oil, paint dirt, etc.

### CAUTION

**DO NOT USE LUBRICANTS.** The use of lubricants can cause product breakage during installation.

2. QD bushing sizes JA through S (see Table 6-1 on page xiii) may be assembled in either conventional or reverse mounting.
  - *Conventional Mounting.* Place the bushing in the hub. Tighten the cap screws finger tight into the threaded holes in the bushing flange
  - *Reverse Mounting:* Place the bushing in the hub and insert the cap screws through the drilled holes in the bushing flange. Tighten the cap screws finger tight into the threaded holes in the hub.

### CAUTION

**When mounting a product on size M through S bushings, the hub jack holes should be positioned away from the bushing saw slot to reduce the possibility of bushing breakage, and insert cap screws through the drilled holes in the hub.**

3. With the key on the shaft, slide the loosely assembled unit onto the shaft so that the cap screw heads are on the outside. Locate the unit in the desired position on the shaft. When installing large or heavy parts in the conventional position, it may be easier to mount the key and bushing on the shaft first, then place the sprocket on the bushing aligning the holes and installing the cap screws.
4. Tighten the cap screws alternately and evenly to the wrench torque specified in Table 6-1 on page xiii.



There should be a 1/8" to 1/4" gap between the bushing flange and the hub. If this gap closes, check the bushing shaft size to make sure it is correct. See Table 6-2.

5. Tighten the set screw over the key to the torque value listed in Table 6-1 on page xiii.

### CAUTION

**Be careful when tightening the screws.** Excessive screw torque may cause damage to bushing and/or product.

**Table 6-1: Recommended Torque Values**

Bush-ing	Recommended Torque				Bush-ing	Recommended Torque			
	Cap Screws		K. S. Set Screw			Cap Screws		K. S. Set Screw	
	Size	lb-in	Size	lb-in		Size	lb-in	Size	lb-in
H	1/4-20x7/8	90	—	—	F	9/16-12x3-5/8	900	3/8-16	290
JA	#10-24x1	60	—	—	J	5/8-11x4-1/2	1620	1/2-13	620
SH	1/4-20x1-3/8	108	1/4-20	87	M	3/4-10x6-3/4	2700	1/2-13	620
SDS	1/4-20x1-3/8	108	1/4-20	87	N	7/8-9x8	3600	5/8-11	1325
SD	1/4-20x1-7/8	108	1/4-20	87	P	1-8x9-1/2	5400	5/8-11	1325
SK	5/16-18x2	180	1/4-20	87	W	1-1/8-7x11	7200	3/4-10	2400
SF	3/8-16x2	360	3/8-16	290	S	1-1/4-7x15	9000	1-8	7200
E	1/2-13x2-3/4	720	3/8-16	290					

**Table 6-2: Bag of Hardware**

Bag of Hardware			
Bushing	Part Number	Bushing	Part Number
H	411682	E	411688
JA	411683	F	411689
SH	411684	J	411690
SDS	411684	M	411691
SD	411685	N	411692
SK	411686	P	411693
SF	411687		



## Adjusting the Finish Roller Press Setting

1. Check the roller setting with standard 2" x 4" (1-1/2" thick) lumber and 1/16" shim. Shim should slide between bottom of roller and the 1-1/2" thickness of 2" x 4" at each end of the roller. If satisfactory plate embedment (100% plate embedment into both top and bottom of the truss) is not present, repeat with only the 2" x 4" lumber.
2. If the roller setting requires adjustment:
  - a) Using a hammer and a wooden block, drive the hanger bearing threaded rod away from the "L-bracket".
  - b) Loosen the 1-3/4" nut above the "L-bracket" 1/8" turn.



- c) Loosen the 1-3/4" lock nut located below the "L-bracket" hanger bracket by hand.
- d) Tighten or loosen the 1-3/4" nut above the "L-bracket" to set the roller height.
- e) Obtain the desired roller height/clearance (see step 1).
- f) Hand tighten the 1-3/4" nut below the "L-bracket" against the "L-bracket".
- g) Tighten the top 1-3/4" nut against the "L-bracket".
- h) Using the hammer and wooden block, drive the hanger bracket threaded rod back towards the "L-bracket" to lock the bottom 1-3/4" nut in place.
- i) Check the roller setting adjustment on the other side of the Finish Roller press. Repeat step 2 if required.

## Cleaning, Lubricating, and Inspecting

### Cleaning

<b>WARNING</b>	
	<p><b>CRUSH AND CUT HAZARD</b></p> <p>Guards must always be in place during operation to avoid serious injury and possibly death.</p> <p>Always replace guards after maintenance is complete and before removing the lockout/tagout device.</p>

<b>CAUTION</b>	
	<p>Do not use compressed air inside the electrical enclosures! It may force contaminants into the electrical connections.</p>

## Lubricating

Proper amounts of motor oil and grease must be maintained at all times. The type of lubrication used, frequency of application, oxidation, and contamination of the lubricant affect service life and parts efficiency of gears and bearings. Improved performance will be obtained by following the guidelines in this manual. Lubrication guidelines are given in this chapter for each part or system that requires lubrication (refer to Table 6-3 on page xv.) The information is also in the *Maintenance Checklist* appendix.

### CAUTION

**Never mix synthetic lubricants with mineral lubricants!**

**Table 6-3: Finish Roller Press Lubrication Chart**

Areas to Be Lubricated	Lubricant	Mfg.'s No. & Grade	Frequency
Reducer/gearbox - Drain fluid and refill after first 150 hrs of service and every six (6) months thereafter. Suggested times: spring and fall—time to change seasonal oil viscosity (light for winters, heavy for summer).	Use oil recommended by manufacturer of speed reducer/gearbox		Every 6 months
Electric Motor	See Note	Impact grease*	See Note
Roller bearing with zerk (2 each)	No. 2 lithium-based grease		Every 200 hours
Roller Chain	Oil	Chain Lube	Every 40 hours

*Note: The motor is equipped with double-shield ball bearings with sufficient grease to last indefinitely. Where the motor is used regularly in dirty, wet, or corrosive atmosphere, it is advisable to add 1/4 ounce of grease per bearing every 1,000 hours of operation—Chevron SRI or equivalent.*

### CAUTION

**Do not overgrease bearings. Injection of excess grease under pressure into sealed bearings may rupture seals.**



Movement of grease through bearings can be checked visually by the appearance of grease at the ends of the bearings.

Old grease should be forced out with shot of new grease. When greasing bearing, wipe the fittings clean.

More bearing failures are caused by dirt introduced during greasing than from insufficient grease.

## Checking Operation of the Finish Roller Press

Visually check the Finish Roller press during operation to see how it completes the connector plate embedment.

<b>WARNING</b>	
	<p><b>PERSONAL INJURY HAZARD.</b></p> <p>Do not operate the Finish Roller press unless all roller and drive chain guards are in place.</p> <p>Be sure all electrical box covers are in place.</p> <p>Periodically check operator push bars to be sure they are operating correctly.</p> <p>Check to be sure the electric bus bar or cable system is operating.</p>

## Motors and Gearboxes

### Electric Motor

<b>WARNING</b>	
	<p><b>PERSONAL INJURY HAZARD.</b></p> <p>To prevent unexpected machine operation or possible electrocution, always turn off and lockout power source before making any machine adjustments or repairs.</p>

Periodically inspect your electric motor for excessive dirt, friction or vibration. Dust may be blown from inaccessible locations using compressed air. Keep the ventilator openings clear to allow free flow of air.

<b>WARNING</b>	
	<p><b>PERSONAL INJURY HAZARD.</b></p> <p>To avoid eye injuries, always wear safety glasses when using compressed air.</p>



- Slotted screwdriver
- Phillips head screwdriver
- External snap ring pliers
- Metric wrench or pliers
- Metric socket head wrench set

## Replacing a Brake Pad

1. Unscrew the manual brake handle extending from the side of the brake motor, if there is one.
2. Remove the fan cover.
3. Remove the fan snap ring.
4. Pry the fan off of the motor shaft.
5. Remove the three (3) fixing screws that hold the brake onto the endbell.
6. Slide the brake off of the brake hub.
7. Slide the brake pad off of the brake hub.
8. If it is a metal inner hub, apply silicone grease to the female spline to reduce metal to metal chattering.
9. Slide the new brake pad onto the brake hub.
10. Place the brake onto the motor endbell in the same manner it was removed.
11. After the three (3) fixing screws are tightened, measure the air gap for proper distance. The procedure is described in the *Adjusting the Air Gap* section.
12. Replace the fan, snap ring and fan cover.

Figure SAFETY-7: Steps 1. through

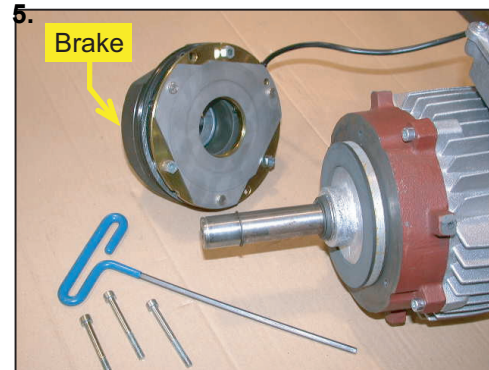

Figure SAFETY-8: Steps 7. and 9.

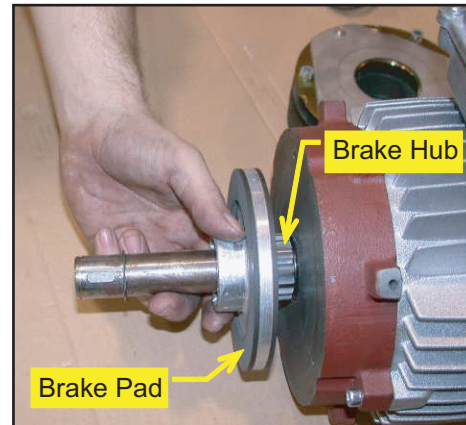

Figure SAFETY-9: Step 12.



## Adjusting the Air Gap

<b>NOTICE</b>	
	<p><b>Adjusting the air gap improperly may damage the motor.</b></p> <p><b>Do not attempt to make this adjustment unless the measured gap is outside the recommended allowance.</b></p>



If the brake monitor continually trips and other causes have been ruled out, the air gap in the brake motor may need to be adjusted. The recommended air gap allowance is between .016 in. and .043 in. To check the current air gap and to adjust it, refer to Figure 6-1 and the following procedure.

1. Unscrew the manual brake handle extending from the side of the brake motor, if there is one.
2. Using a feeler gauge, measure the gap between the armature disk and brake housing, shown in Figure 6-1. Measure completely around the brake and record any variations in the gap measurement.



Slotted screwdriver  
 Phillips head screwdriver  
 External snap ring pliers  
 Metric wrench or pliers  
 Metric socket head wrench set

**Figure 6-1: Measuring the Brake Disk Air Gap**

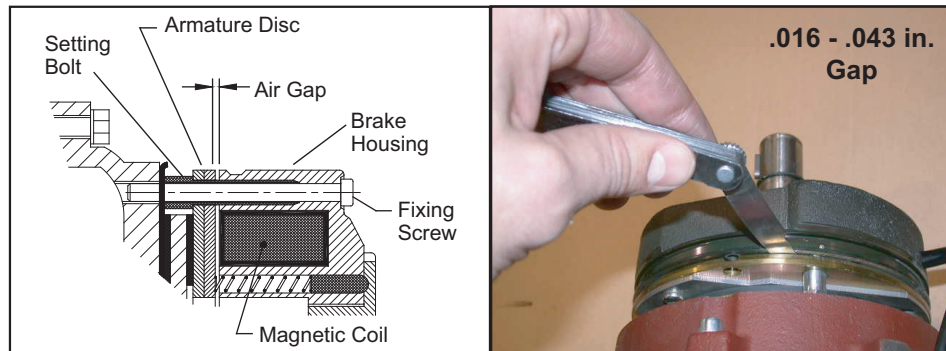

3. If the measurement is outside the allowance recommended at any point around the circumference of the brake, adjust the brake disk air gap using the following steps:
  - a) Remove the fan cover.
  - b) Remove the fan snap ring.
  - c) Pry the fan off of the motor shaft.

- d) Adjust the setting bolt as needed to reach the recommended gap. A 1/4 or 1/2 turn is usually sufficient for adjusting purposes. See Figure 6-2.

**Figure 6-2: Adjusting the Setting Bolt**

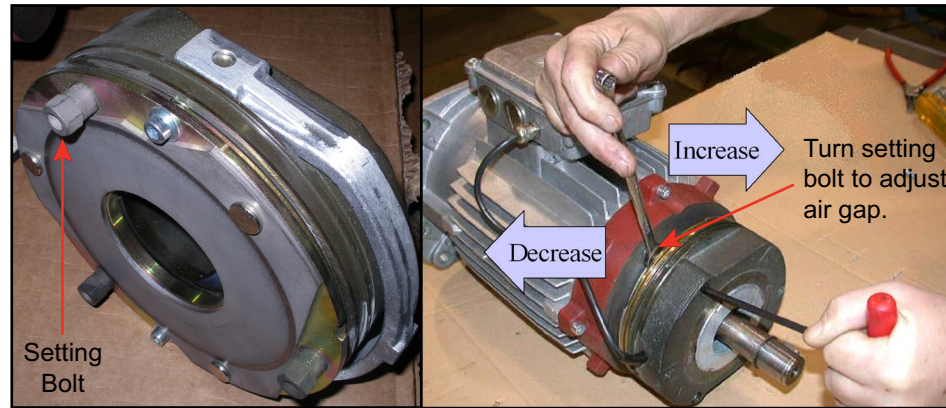

4. Check the air gap again to ensure it is now within the recommended range. It may be necessary to adjust a setting bolt more than once because the other setting bolts may affect it.



The air gap distance must be uniform in all three (3) places!

5. Tighten all of the fixing screws.
6. Re-attach the fan blades, snap ring, fan cover, and handle.

## Adding and Changing Oil

Check the oil in the gearbox reducer at least once a year. When additional oil is needed, use one of the oils recommended in Table 6-4 or a comparable type.

**Table 6-4: Recommended Brake Motor Oil**

ISO VG	Brand and Type			
	Operating Temperature of 23°F to 104°F (-5°C to 40°C)		Operating Temperature of 22°F to 176°F(-30°C to 80°C)	
220	Shell	Omala EP220	Shell	Omala HD220
	Mobil	Mobilgear 630 Mobilgear XMP220		

Drain and refill the oil in the gearbox every 10,000 working hours. Working hours is the amount of time the motor is actually running and is indicated by the hour-meter located on the side of the electrical enclosure (on 1-enclosure systems only). When refilling the oil, use one of the oils shown in Table 6-4 or a comparable type

Gearboxes on machines shipped before 15 December 2006 have a capacity of approximately 10.64 quarts. Gearboxes on machines shipped on or after 15 December 2006 have a capacity of approximately 13.64 quarts.

**Figure 6-3: Brake Motor**





## Replacing the Motor

1. Verify that there is no load on the reducer so when the brake is removed, the load is not released.
2. Drain oil from the gearbox or rotate motor so oil will not leak out.
3. Remove the bolts holding the motor on the gearbox.
4. Remove the existing motor.
5. Remove and clean the gasket surface of the gearbox. Make sure no debris falls into the gearbox during this time.
6. Place the clean gasket back in the gearbox.
7. Slide the new motor into position, making sure the input pinion gear teeth properly mesh with the input gear teeth.
8. Rotate the motor as needed to seat the flange surface and make sure the bolt holes are properly aligned.
9. Re-install the bolts.
10. If needed, fill the reducer with an oil recommended in Table 6-4.
11. Reconnect power and remove lockout/tagout devices.



Sockets set  
(metric and  
English)

Screwdrivers  
(slotted and  
Phillips)

Rubber mallet

Pry bars

If you continue to have problems after performing all applicable troubleshooting steps and reviewing the topic in the *Maintenance* chapter, call MiTek Machinery Division Customer Service at the numbers listed in Figure 1-2.



**Refer to...**

*Maintenance* chapter for procedures and graphics

*General Information* chapter for truss terminology

*Glossary* for additional terminology

Figure 1-2 to contact MiTek Machinery Division Customer Service

## Safety Notes for Troubleshooting

WARNING	
	<p><b>ELECTROCUTION, HIGH PRESSURE, CRUSH, CUT, AND CHEMICAL HAZARDS!</b></p> <p><b>Read all notes in this section AND the safety section in the preliminary pages before operating or maintaining this equipment.</b></p> <p><b>Most solutions are described in more detail in the <i>Maintenance</i> chapter and may have more safety notes included there.</b></p>

- All warnings located in the safety section in the preliminary pages apply at all times.
- When this graphic appears, you must lockout and tagout the equipment using approved methods described in OSHA 29 CFR 1910.147 before continuing with the procedure or troubleshooting.
- If the lockout/tagout graphic does not appear, it is recommended that you still de-energize the machine unless energy is required for the troubleshooting process. If it is absolutely necessary to troubleshoot an energized machine, follow NFPA 70E for proper procedures and personal protective equipment.
- All electrical work must be performed by a qualified electrician.
- Read this manual for information and procedures related to the specific maintenance or troubleshooting issue before attempting any maintenance!
- Safety goggles and a dust mask must be worn for all cleaning steps outlined in this manual. When using cleaning and lubrication solutions, a respirator rated for use with those solutions must be worn as well as gloves resistant to the solution.



## ***Operational Notes for Troubleshooting***

- Do not use compressed air inside the electrical enclosures! It may force contaminants into the electrical connections.
- Clean and lubricate the equipment as a first step in most troubleshooting processes. Most malfunctions are caused by inadequate preventive maintenance.

**Figure 7-1: Never Use Compressed Air Inside an Electrical Enclosure**





**Should you lockout/tagout to safely perform this action?**



**Table 7-1: Finish Roller Press Troubleshooting Guide**

Problem	Possible Cause	Possible Solution
No power to system - Finish Roller press does not operate	No power	Connect power to system
	Tripped circuit breaker(s) or blown fuse(s) in disconnect	Reset circuit breaker(s), or replace fuse(s)
	Control current fuse blown	Replace control current fuse
	Pushbutton controls not working properly	Replace pushbutton control
	Push bar limit switches not properly adjusted or damaged	Adjust or replace push bar limit switches
Machine jumps or violently reacts during starts and stops	Chains not properly adjusted or aligned	Adjust chain (proper chain adjustment is 1/4" movement to both sides of center)
	Clutch pads worn/failed	Inspect clutch
Reducer/gearbox overheating	Improper lubrication	Lubricate properly
	Insufficient oil	Check oil level
	Too much oil causes churning - excessive heat generated by fluid friction of churning oil	Flush and refill to proper oil level with grade specified on reducer name plate or in this manual, Table 6-4 on page xxi
	Wrong grade of oil	
Noise and vibration in reducer/gearbox	Loose mounting bolts	Check mounting bolts and lock washers and tighten
	Insufficient oil - low oil level reduces muffling effect of oil	Check oil level Flush and clean reducer and replace oil
	Failed bearings - wear of bearings can be caused by dirt in oil	Replace reducer or worn bearings
	Loose parts	Inspect reducer for broken parts, loose bolts, nuts
		Check keys for proper fit

## Navigating the Parts List Appendix

### Finding the Part Number

For a complete list of replacement parts, or if you're unsure of which spare part you need and would like to see a picture, use the electronic Parts Guide for this machine. The electronic Parts Guide was included with this manual on a CD-ROM. It can also be found on our Web site.

**Table 8-1: How to Find Your Part Number**

Using Our Web Site: <a href="http://www.mii.com/machinery">www.mii.com/machinery</a>	Using Your Parts Guide CD-Rom
<ol style="list-style-type: none"> <li>1. Click <i>Machinery</i>, then roll your cursor over <i>Ordering Parts</i>.</li> <li>2. Click on <i>Parts Guide</i> to access the Quick Reference Parts Guide.</li> <li>3. Choose your equipment name and browse through the pictured parts to find your part number.</li> </ol>	<ol style="list-style-type: none"> <li>1. Place the CD in your computer's CD drive. It should automatically launch a Main Menu screen.</li> <li>2. Click the graphic for the machine for which you are ordering parts.</li> <li>3. Browse through the pictured parts to find your part number.</li> </ol>

### Ordering the Parts With Your Part Number

There are three easy ways to order your part after you determine the part number. Each column in Table 8-2 describes one of the methods.



**Table 8-2: How to Order Your Part Using the Part Number**

Using Our eStore™ (an account is required):	Using E-Mail	Using the Phone
Click the eStore link from the Web site, <b>OR</b> Click the eStore link from the Parts Guide, <b>OR</b> Type <a href="http://estore.mii.com">http://estore.mii.com</a> into your web browser.	Send an e-mail to <a href="mailto:mitekparts@mii.com">mitekparts@mii.com</a> with all relevant information, including the part number.	Call us at 1-800-523-3380 and select "Parts Orders".

## Safety Notes When Replacing Parts

<b>NOTICE</b>	
	<p>Only use the exact replacement parts that are specified by MiTek. Substitutions may harm your equipment.</p>

<b>WARNING</b>	
	<p><b>ELECTRICAL HAZARD!</b></p> <p>All electrical work must be performed by a licensed electrician.</p> <p>Follow approved lockout/tagout procedures (OSHA 29 CFR 1910.147).</p>

<b>WARNING</b>	
 	<p><b>ELECTROCUTION HAZARD.</b></p> <p>Always turn the power off by activating an E-stop when the equipment is not in operation.</p> <p>Always verify that all power to the machine has been turned off and follow approved lockout/tagout safety procedures (OSHA 29 CFR 1910.147) before performing any maintenance on this equipment.</p>

**Drawings are inserted at the back of the manual.**

**Table 9-1: Attached Drawings**

Description	Drawing Number
Finish Roller Assembly, 14'	68300
Finish Roller Assembly, 16'	68400
Electrical, Finish Roller with Soft-Start	90113



# Document Evaluation

## *Appendix E*

A form is included in this appendix so you can provide MiTek with feedback on the usefulness of this manual. We make an ongoing effort to improve the value of our documentation, and your views are important to us.

Please follow the instructions on the form to provide us with comments or suggestions that will help us improve the quality of our documentation services.





# Document Evaluation Form (cont'd)

Identify any inaccuracies in the document.

What are the three best features of the document?

What are the three worst features of the document?

What did you like/dislike about the illustrations?

Your Name:

Date:

Company Name:

Address:

Phone:

Email:

**Please mail this form to:**

MiTek  
Machinery Operations  
301 Fountain Lakes Industrial Drive  
St. Charles, MO 63301  
Attn: Engineering Manager

**Or fax this form to:**

636-328-9218  
Attn: Engineering Manager

*If you do not receive a reply within 45 days, please call our Customer Service Department and ask for the Documentation Specialist or Engineering Manager: 800-523-3380.*

# Index

## A

air gap 34, 37

## B

before you begin 18

brakes

disc 34, 37

replacing 33

## C

caution logo viii

Customer Service 2

## D

danger logo viii

delivery 11

disconnect switch 18

document evaluation form 44

drawings

description 43

drawing number 43

drawing numbers 43

## E

electrical

installation

electrical

disconnect enclosure 14

emergency stop (E-stop) pushbuttons 18

emergency stops 18

environmental logo viii

equipment layout 13

evaluation of documentation 44

## F

Finish Roller press

equipment layout 13

operating procedure 20

operator control interface 19

safety during troubleshooting 38

## G

gearboxes 32

## H

hazard indicator viii

## I

installation

checklist 15

delivery 11

electrical 14

lifting 14

responsibilities 11

unloading 12

insurance 12

## L

lockout/tagout

guidelines xi

procedure xii, xiv, xxiii, xxv

## M

motor 32

motors

replacing 37

## N

notice logo viii

notice of change vi

# Index

## O

operation  
stopping 18

## P

page change vi  
parts list  
navigation  
patents v

## R

replacement parts 41  
parts list  
requirements  
electrical 8  
location 8  
mechanical 9  
responsibilities  
during installation 11  
of mitek 6  
training provided 10  
restricted zones xvi, xxvii  
return goods v

## S

safety  
during troubleshooting 38  
lockout/tagout xi  
restricted zones xvi, xxvii  
safety indicators viii  
safety rules viii, xviii  
shipping  
contents and weight 9  
spare parts, *see* replacement parts  
specifications  
general 3  
motor 3  
stop motion 18

## U

unloading 11  
unpacking 11

## W

warning logo viii  
weight  
system components weight 9

# Glossary

<b>actuate</b>	to activate, put into action
<b>aisle pad</b>	a type of jiggging used when a connector plate needs to be embedded where the table surface gives way to a walk-through aisle
<b>amperage</b>	the strength of an electric current, expressed in amperes
<b>anchor plate</b>	a steel plate that holds the tables in place; it is anchored to the concrete floor and the tables are welded to it
<b>auto-eject</b>	a pneumatic system that raises the truss off the tables and automatically places the truss on the stand-alone conveyors with the use of a transfer roller
<b>bumper</b>	a safety device on each corner of the gantry head (for a total of 4); when the bumper is depressed, the gantry head motion stops
<b>bus bar</b>	an electrical device that allows multiple gantry heads to be used simultaneously
<b>connector plate</b>	the nail-plate that is embedded into the production material to hold it together
<b>cushion</b>	an attribute of a hydraulic cylinder that allows adjustment of the pressure in each cylinder
<b>directional buttons</b>	the 2 black buttons on the pendant control station that tell the gantry head which direction to move
<b>end-eject</b>	a pneumatic system that raises the truss off the tables and allows the truss to be manually pushed or pulled off the end of the tables; this system requires that the gantry head rolls back over the truss or a device must be installed to raise the gantry head when it is parked
<b>gantry head</b>	the entire traveling weldment that houses the Roller to embed the connector plates
<b>inner side</b>	refers to the end of the gantry head housing; the side closest to the tables; both ends have an inner side—one can see the inner side of both ends when standing on or between the tables

# Glossary

<b>jigging</b>	any of several devices used to hold the truss in place on the tables
<b>joystick</b>	an option that replaces the pendant control station to control movement of the gantry head
<b>layout</b>	a scaled diagram of the location of components and the space that they occupy
<b>leveling screws</b>	large cap head screws that thread into the table legs and allow the table height to be adjusted and leveled
<b>light bar</b>	the perimeter access guarding device that uses multiple light beams to detect when something is in the way of the gantry head and stops the machine to prevent injury or damage; the RoofTracker uses a set of 3-beam light bars on both sides of the gantry head
<b>limit switch</b>	an electro-mechanical device that consists of an actuator mechanically linked to a set of contacts; when an object comes into contact with the actuator, the device operates the contacts to make or break an electrical connection
<b>lockout/tagout</b>	a means of isolating a piece of equipment from its energy source so maintenance can safely occur; guidelines provided in OSHA 29 CFR 1910.147
<b>lubricator</b>	a device that allows controlled amounts of lubricants into the pneumatic system
<b>motor end</b>	used to indicate which end of the gantry head is being discussed; the end of the gantry head that houses the motor
<b>operator control interface</b>	the method in which the operator controls the machine; it may be a touch screen, a control panel, etc.
<b>outer side</b>	refers to the end of the gantry head housing; the side farthest from the tables; both ends have an outer side—one can see the outer side of the one end when standing at the pendant control station
<b>pendant control station</b>	where the operator stands to use the pendant that controls movement of the gantry head

# Glossary

<b>pilot valve</b>	a pneumatic valve that operates the setup valve to control the release or cessation of air in each setup; it is located on the bottom-chord end of one table in each setup
<b>plate</b>	see <i>connector plate</i>
<b>PLC</b>	Programmable Logic Controller; a solid-state control device that can be programmed to control process or machine operations. It consists of five basic components: processor, memory, input/output module, the power supply, and the programming device.
<b>port</b>	a connection point for a peripheral device
<b>potentiometer</b>	a control knob that is a dial; allows a range of values to be set by turning the dial, commonly found on the PLC
<b>proximity switch</b>	a switch that uses an electromagnetic field to detect when an object is near, there is no physical contact between the object and the switch; inductive proximity switches detect only metal objects, capacitive proximity switches can sense both metallic and non-metallic objects
<b>puck</b>	a type of jiggging that is small and round
<b>qualified person</b>	a person or persons who, by possession of a recognized degree or certificate of professional training, or who, by extensive knowledge, training, or experience, has successfully demonstrated the ability to solve problems relating to the subject matter and work—ANSI B30.2-1983; one who has skills and knowledge related to the construction and operation of the electrical equipment and installations and has received safety training on the hazards involved—NEC2002 Handbook
<b>receiver bar</b>	the light bar that receives the signal from the transmitter bar; every light bar set consists of a receiver bar and a transmitter bar
<b>regulator</b>	a component of the pneumatic system that connects to the main air source and regulates the air pressure allowed into the system

# Glossary

<b>Roller</b>	the large roller inside the gantry head that innately embeds the plates into the truss
<b>setup valve</b>	a component of the pneumatic system that control the flow of air to the rest of the setup
<b>side-eject</b>	a pneumatic system that raises the truss off the tables and allows the truss to be manually pushed or pulled off the side of the table and onto the stand-alone conveyors
<b>slider pad</b>	a type of jigging used when a connector plate needs to be embedded where the table surface gives way to a slot for the Ejector
<b>solenoid</b>	an assembly used as a switch consisting of a coil and a metal core free to slide along the coil axis under the influence of the magnetic field
<b>stand-alone conveyor</b>	the conveyor system that carries the truss from the tables to the Finish Roller and out to the stacker
<b>stop</b>	a type of jigging that is long and straight
<b>take-up bearing</b>	adjusts the height of the roller
<b>torque</b>	a turning or twisting force
<b>transfer roller</b>	a motorized roller sitting perpendicular to the tables on an auto-eject system; it automatically transfers the truss from the Ejectors to the stand-alone conveyors
<b>transmitter bar</b>	the light bar that transmits the signal to the receiver bar; every light bar set consists of a receiver bar and a transmitter bar
<b>VFD</b>	Variable Frequency Device; controls the speed of the cycle
<b>voltage</b>	Equal to the difference of electric potential between two point on a conducting wire carrying a constant current of one ampere when the power between the points is one watt



# Finish Roller

Roller Press

# Finish Roller

Roller Press

# Finish Roller

Roller Press



001010  
Rev. D



001010  
Rev. D



001010  
Rev. D