

Service Bulletin

Machinery Affected: *RoofGlider® RoofTracker RST, AutoPress 14TL™ Presses*

Document: SB199

Title: Replacing a Bearing and Adding Spacers

Applies To: Current RexNord XWT207-2-7/16 Replaced With SKF

Distribution: Customers, Upon Order



Copyright © 2012 MiTek®. All rights reserved.

MiTek Machinery Division
301 Fountain Lakes Industrial Drive
St. Charles, MO 63301
Phone: 800-523-3380
www.mii.com

Item # and Rev.	SB199
Date Created	23 Aug. 2012
Created By	R. Tucker
Reviewed by	G. Kocurek
Approved by	M. Kanjee
Revision Date	
Revised By	
Approved By	
Applicability/ Effectivity	All through creation date

Overview

The drive wheel bearings originally used on the equipment listed on the title page are no longer available. This document describes how to install the new bearings with the spacers required for a perfect fit.

The parts included in this kit are shown in Table 1. Please ensure all parts are present before starting this procedure.

Table 1: Parts in SB199KIT

Qty.	Part Description	Part #
1	Bearing	419856
3	Spacer	25522
1	Service Bulletin Document	SB199

If you have any questions, call MiTek Machinery Division Customer Service at 800-523-3380.





Before starting this procedure, inspect the drive and idle wheels. If they are in need of replacement, this is an excellent time to replace them. Refer to your Equipment Manual or electronic Parts Guide for the correct part number.

Procedure





Electrical Lockout/Tagout Procedures When Working on a Machine Outside the Machine’s Main Electrical Enclosure

	 WARNING
	<p>ELECTROCUTION HAZARD!</p> <p>Verify that all power to the machine has been turned off and follow approved lockout/tagout safety procedures before performing any maintenance.</p> <p>All electrical work must performed by a qualified electrician.</p> <p>If it is absolutely necessary to troubleshoot an energized machine, follow NFPA 70E for proper procedures and personal protective equipment.</p>

Before performing maintenance on any machine with electrical power, lockout/tagout the machine properly. When working on a machine outside of the machine’s main electrical enclosure, not including work on the electrical transmission line to the machine, follow your company’s approved lockout/tagout procedures which should include, but are not limited to the steps here.

1. Move the gantry to the parking stand, and position it so the bearing being replaced is in the aisle between the parking stand and the first table.
2. Engage an E-stop on the machine.
3. Turn the disconnect switch handle on the machine’s main electrical enclosure to the “off” position. See Figure 1.

	 WARNING
	<p>ELECTROCUTION HAZARD.</p> <p>When the disconnect switch is off, there is still live power within the disconnect switch’s enclosure. Always turn off power at the building’s power source to the equipment before opening this electrical enclosure!</p>



4. Attach a lock and tag that meets OSHA requirements for lockout/tagout.

Figure 1: Lock and Tag Shown on Electrical Enclosure of a *RoofGlider Press**





1. Turn the disconnect switch to the OFF position.
2. Push the red portion of the disconnect switch to the left to access the lock point.
3. Place a lock through the hole in the red portion and attach a tag to the lock.
4. Close the lock and ensure only the person responsible for the maintenance has a key.



* Equipment other than the *RoofGlider press* may have a different electrical enclosure and disconnect switch, but they all have a hole accessible for the lock when in the Off position.

	 WARNING
	<p>ELECTRICAL HAZARD.</p> <p>Ensure the disconnect switch is in the Off position and a lock and tag securely attached before proceeding.</p>

Hydraulic System Lockout/Tagout Procedure



This section applies to the *AutoPress 14TL* hydraulic platen press:



	 WARNING
	<p>MOVING PARTS CAN CRUSH AND CUT.</p> <p>Always verify that power to the machine has been turned off and follow approved lockout/tagout procedures.</p> <p>Turn off the air switch or shutoff valve before performing any maintenance on the equipment.</p>

	 WARNING
	<p>HIGH PRESSURE HAZARD.</p> <p>Bleed pneumatic or hydraulic lines before performing any maintenance on the pneumatic or hydraulic systems.</p>

Pneumatic System Lockout/Tagout Procedure

If your equipment uses pneumatic (compressed) air for jiggling, lifters, ejectors, receivers, etc, this section applies:

	 WARNING
	<p>MOVING PARTS CAN CRUSH AND CUT.</p> <p>Always verify that power to the machine has been turned off and follow approved lockout/tagout procedures.</p> <p>Turn off the air switch or shutoff valve before performing any maintenance on the equipment.</p>

	 WARNING
	<p>HIGH PRESSURE HAZARD.</p> <p>Bleed pneumatic or hydraulic lines before performing any maintenance on the pneumatic or hydraulic systems.</p>

Procedure

Refer to Figure 2 when completing the procedure.

- When replacing the bearing on the drive-wheel side, use the procedure on page 7.
- When replacing the bearing on the sprocket side, use the procedure on page 8.

Figure 2: Bearing and Spacer Assembly

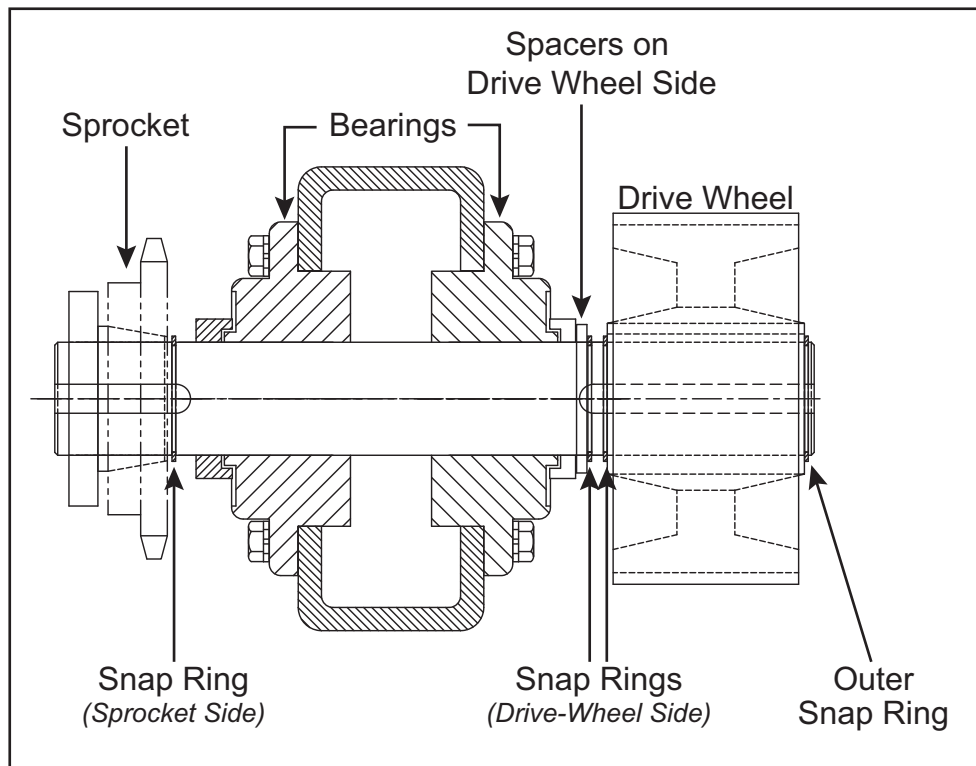



Replacing the Drive-Wheel Side Bearing



The gantry must be parked on the parking stand, with the bearing being replaced in the aisle between the parking stand and the first table.

1. After positioning the gantry and locking/tagging out as instructed on page 3, loosen the chain tension on the sprocket side of the bearing assembly.
2. If a lubrication line is present on the old bearing, carefully remove it from the bearing. It will be reattached to the new bearing.
3. Remove the snap rings (2 or 3 depending on gantry style) on the drive wheel side. Set them aside in a safe place.
4. Remove the drive wheel and key. Set them aside in a safe place.
5. Remove the hardware holding the bearing on the frame. Set it aside in a safe place.
6. Loosen the set screws on the bearing (typical quantity is 2).
7. Slide the damaged bearing off the shaft. Discard the bearing.
It may require anti-cease lubricate to loosen the bearing.
8. Slide the new bearing on and bolt it in place using the existing hardware.
9. Slide the appropriate number of spaces onto the shaft until they firmly rest against the bearing face. Use just enough spacers so they fill the gap between the bearing shoulder and snap ring groove on the shaft.
10. Assemble the previously-used snap rings in their place on the bearing side of the shaft.
11. Add the key and slide the drive wheel up to the snap ring.
12. Add the outer snap ring to keep the wheel from coming off.
13. If a lubrication line was present on the old bearing, screw the enclosed grease fitting into the tapped hole on the new bearing and reattach the lubrication line. If no lube line was present, discard the enclosed grease fitting.
14. Re-tension the chain.
15. Remove the lockout/tagout devices.



Replacing the Sprocket-Side Bearing



The gantry must be parked on the parking stand, with the bearing being replaced in the aisle between the parking stand and the first table.

1. After positioning the gantry and locking/tagging out as instructed on page 3, loosen the chain tension on the sprocket side.
2. If a lubrication line is present on the old bearing, carefully remove it from the bearing. It will be reattached to the new bearing.
3. Remove the snap ring on the sprocket side. Set it aside in a safe place.
4. Mark the location of the sprocket on the shaft for easier assembling.
5. Remove the sprocket and key. Set them aside in a safe place.
6. Remove the hardware holding the bearing on the frame. Set it aside in a safe place.
7. Loosen the set screws on the bearing (typical quantity is 2).
8. Slide the damaged bearing off the shaft. Discard the bearing.
It may require anti-cease lubricate to loosen the bearing.
9. Slide the new bearing on and bolt it in place using the existing hardware.
10. Assemble the previously-used snap ring in its place on the sprocket side of the shaft.



The spacers are only required when the bearing on the drive-wheel side is being replaced. When the bearing on the sprocket side is being replaced, the spacers are not necessary, but can be used if any uncertainty exists.

11. Add the key and slide the sprocket so it's aligned with the other sprockets. Use the mark made in step 4 for proper sprocket location.
12. If a lubrication line was present on the old bearing, screw the enclosed grease fitting into the tapped hole on the new bearing and reattach the lubrication line. If no lube line was present, discard the enclosed grease fitting.
13. Re-tension the chain.
14. Remove the lockout/tagout devices.

END OF SERVICE BULLETIN