

## **SERVICE BULLETIN #141a March 6, 1997**

### **-Engineering Department-**

In order to keep all MiTek® Cyber Saws® up to date with new designs we are issuing a service bulletin to all MiTek® Cyber Saw® owners. The following changes should be made and/or the following should be checked.

1. In order to facilitate easier adjustment of the proximity switches on the quadrant angulation the following changes should be made to the proximity switch brackets located on the quadrant mounting bracket.
  - The M8 tapped hole in the proximity switch brackets should be drilled thru with a 13/32 (10mm) drill. The proximity switch will be held with two nuts supplied with the proximity switch.  
**See Figure 1. This should only be done on quads #1-#4.**
  - The gap between the proximity switch and the prox cam should be set between .020" and .030".
2. To improve accuracy of angulation, the prox cam should be replaced with the new four step cam. **See Figure 1**

**The M8 hole should be drilled thru only on quads #1-#4.**

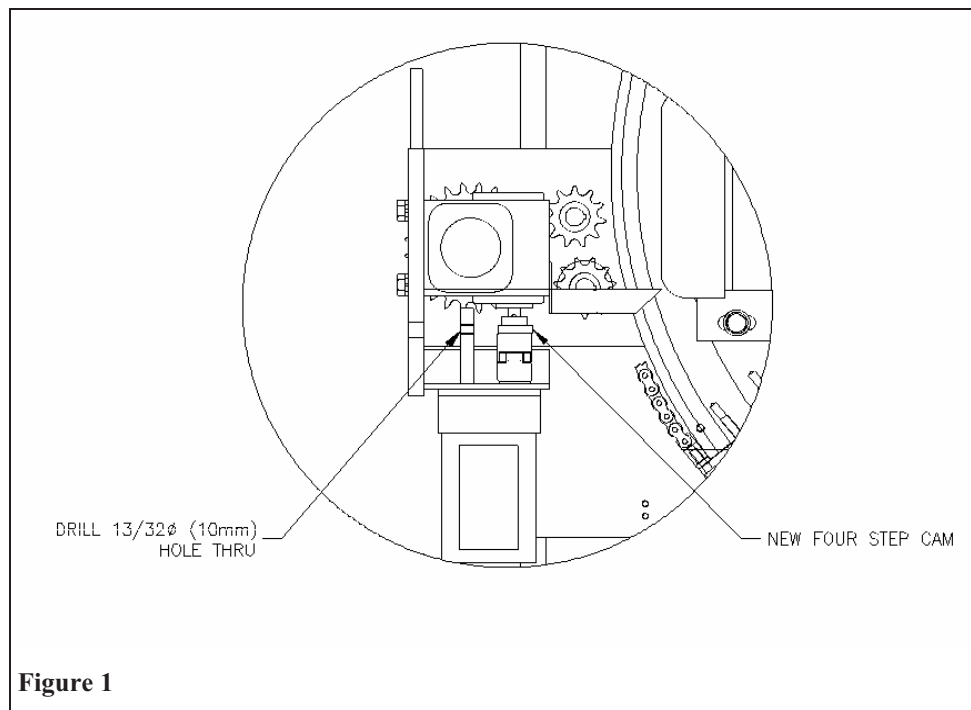

Parts needed:

Item	Quantity	MiTek Part No.
4 Step Angulation Cam	5 or 6	B77973

3. To improve accuracy of the centerlines, the prox cam weldment should be replaced with the new four step cam weldment. **See Figure 2**

4. Please check the centerline proximity switches for full alignment with the prox cam.

- If necessary, grind bottom hub of the coupling to insure full alignment. **See Figure 2**
- The gap between the proximity switch and the prox cam should be set between .020" and 0.030".
- Use Loctite #262 red on setscrews in coupling.
- Please be certain coupling halves are fully engaged.

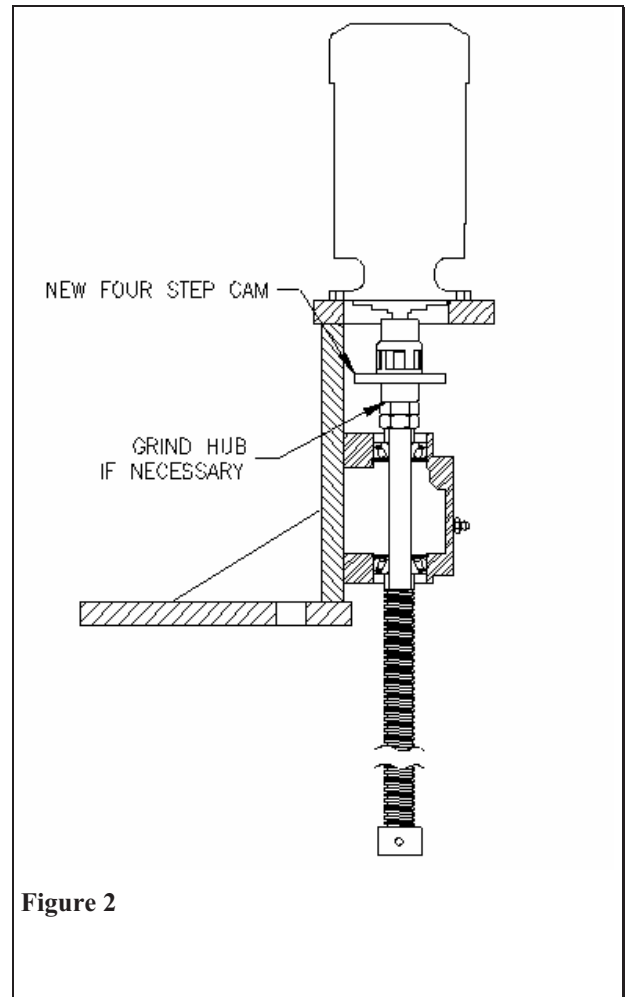

Parts Needed:

Item	Quantity	MiTek Part No.
Prox Cam Weldment	5 or 6	B77839

5. Please check brake on carriage. The brake should be air operated. See **Figure 3 & Figure 4**

- The operating pressure of the saw should be 100 PSI. The pressure switch located in the stationary end control panel should be set equal to or no more than 10 PSI lower than the operating pressure of the saw.

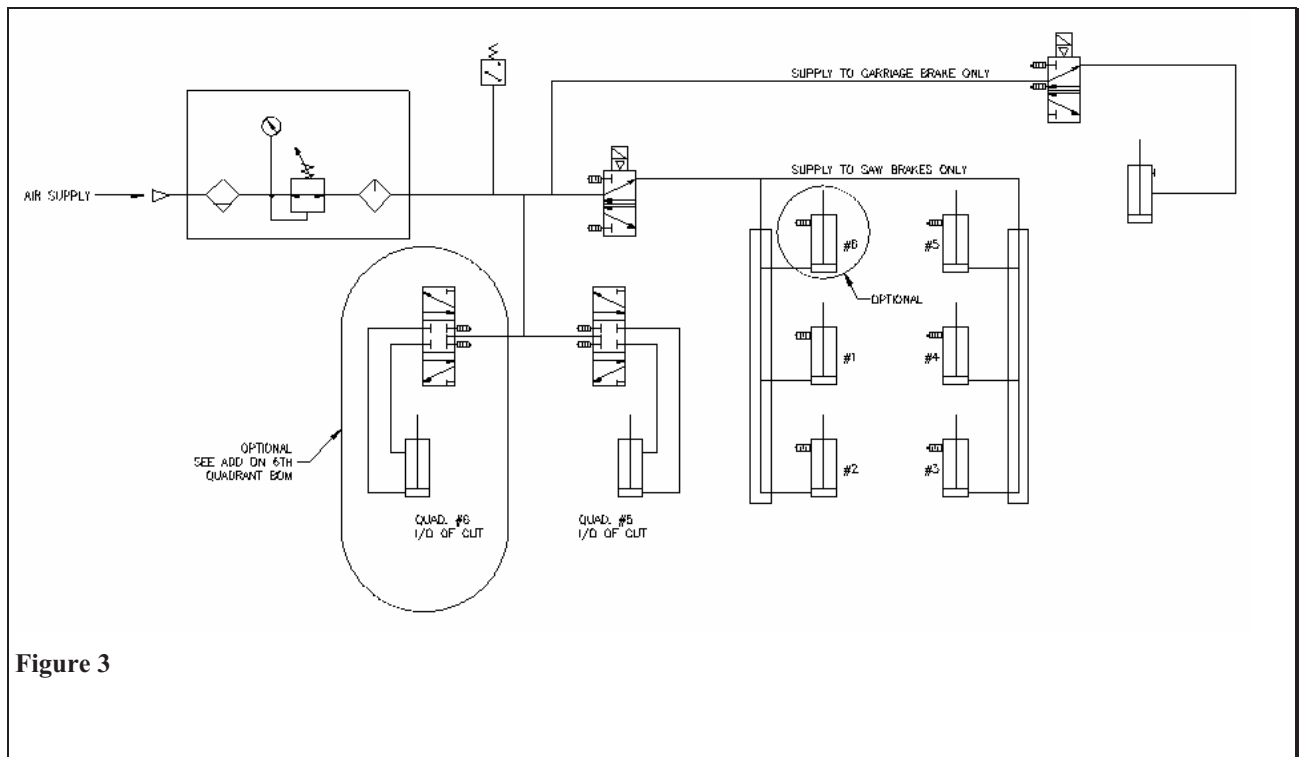
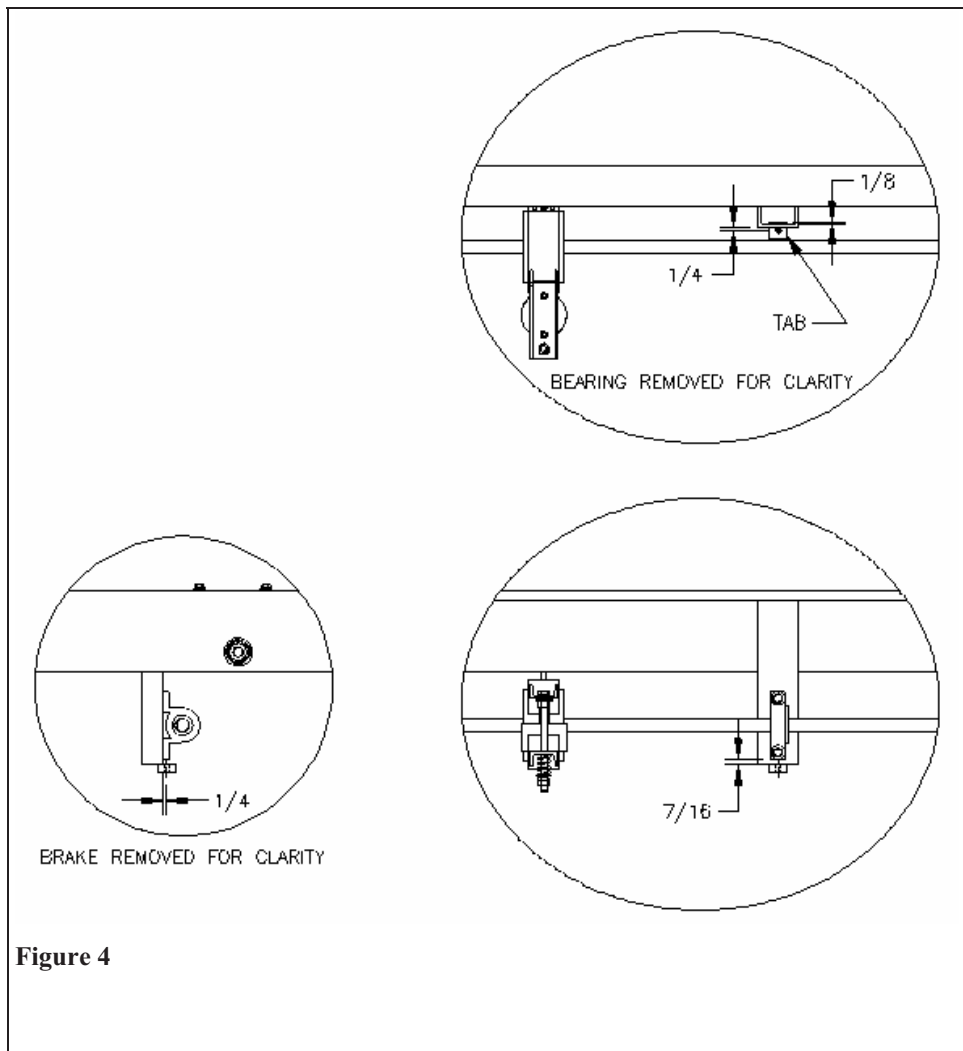

**Figure 3**

- To allow easier adjustment of pillow block bearings which support the carriage drive shaft, please add adjustment tab as per **Figure 4**.

Parts Needed:

Item	Quantity	MiTek Part No.
Block, Spring, Guard	3	B77837
3/8-16 x 1-1/2 H.H.C.S.	3	327265
3/8-16 Hex Nut	3	361605



**Figure 4**

7. To improve accuracy of infeeds, an extra proximity switch and new prox target is to be added to the stationary and carriage infeeds. **See Figures 6 & 7.** The prox cam in the powered infeed brackets is to be replaced with a counting sprocket weldment. **See Figure 8.** A 1/2" hole needs to be drilled in the rear side of both control panels for the cord grip connector. **See Figure 5.** Wire new stationary end prox to terminal block labeled **I89.** Wire new carriage end prox to terminal block labeled **I183.** **The calibration distance from blade at 90° to inside edge of lumber conveyor shall be 10".**

Parts needed:

<b>Item</b>	<b>Quantity</b>	<b>MiTek Part No.</b>
Infeed Prox Weldment	2	B79845
Prox Spacer Double	2	B79839
Infeed Prox Cover	2	N77451
Proximity Switch	2	515831
Prox Cord 90°	2	508056
Sprocket Weldment	2	B79840
Prox Switch Bracket	2	B77441
Guard Powered Infeed LH	1	D77469
Guard Powered Infeed RH	1	D77470
Prox Cord Grip Connector	2	511681

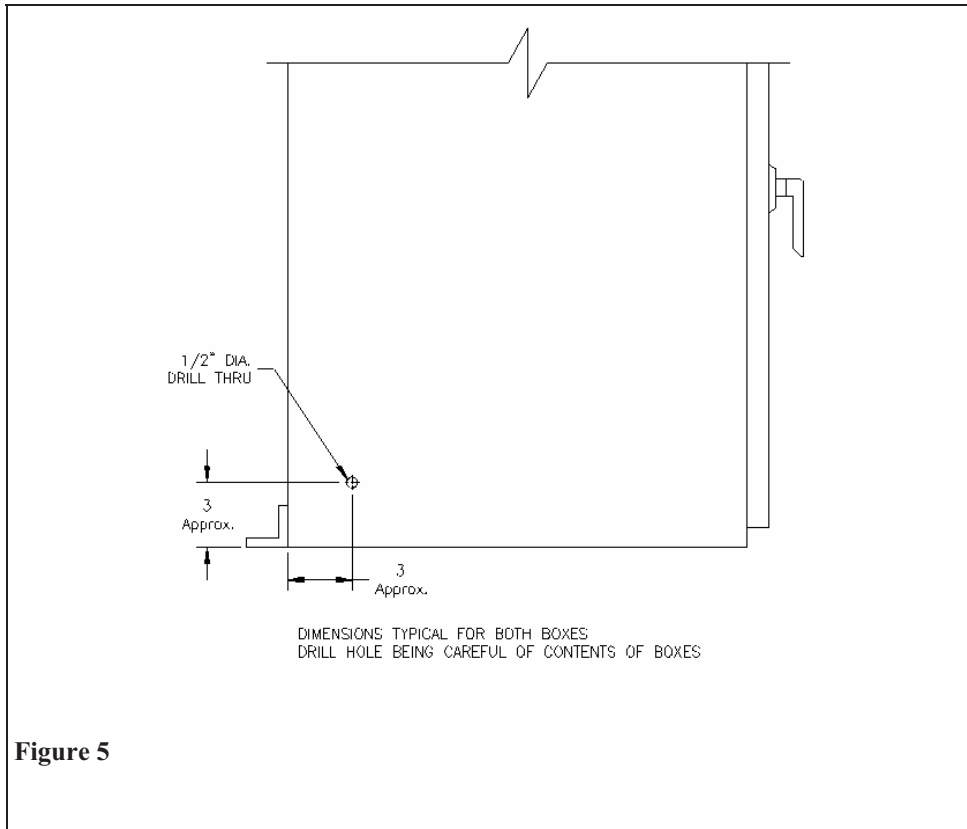

Figure 5

**The calibration distance from blade at 90° to inside edge of lumber conveyor shall be 10".**

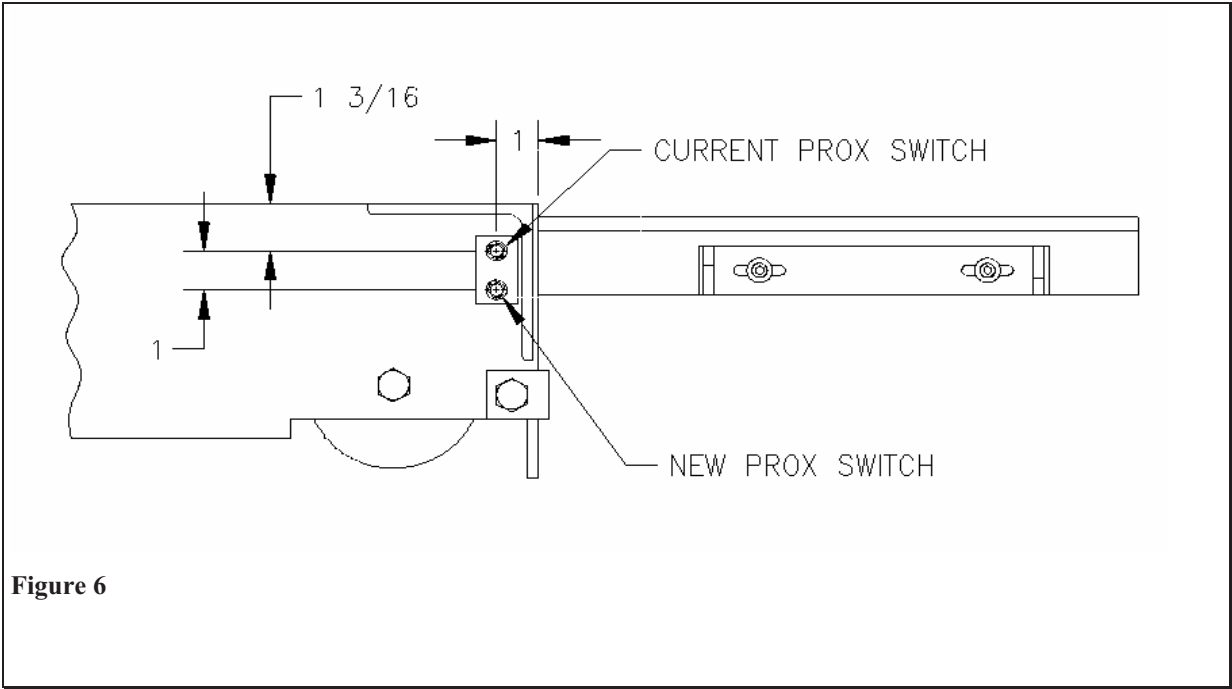

Figure 6

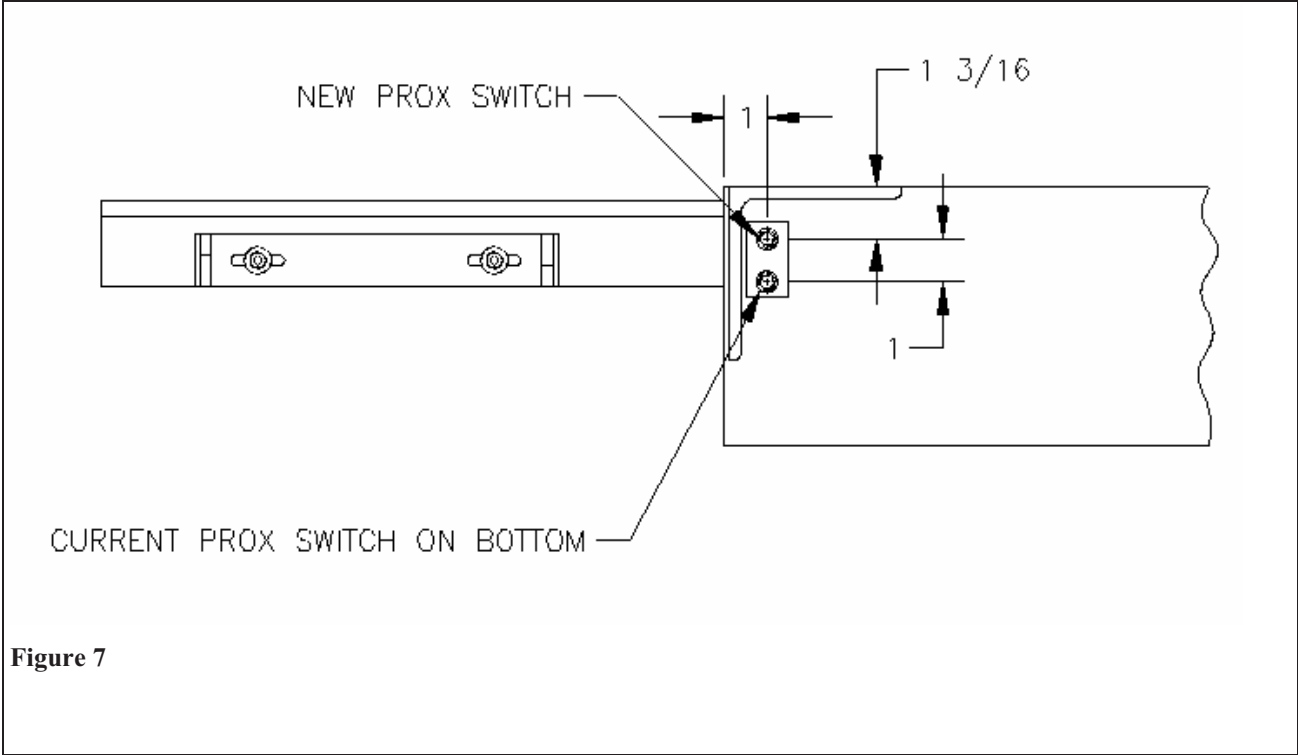

Figure 7

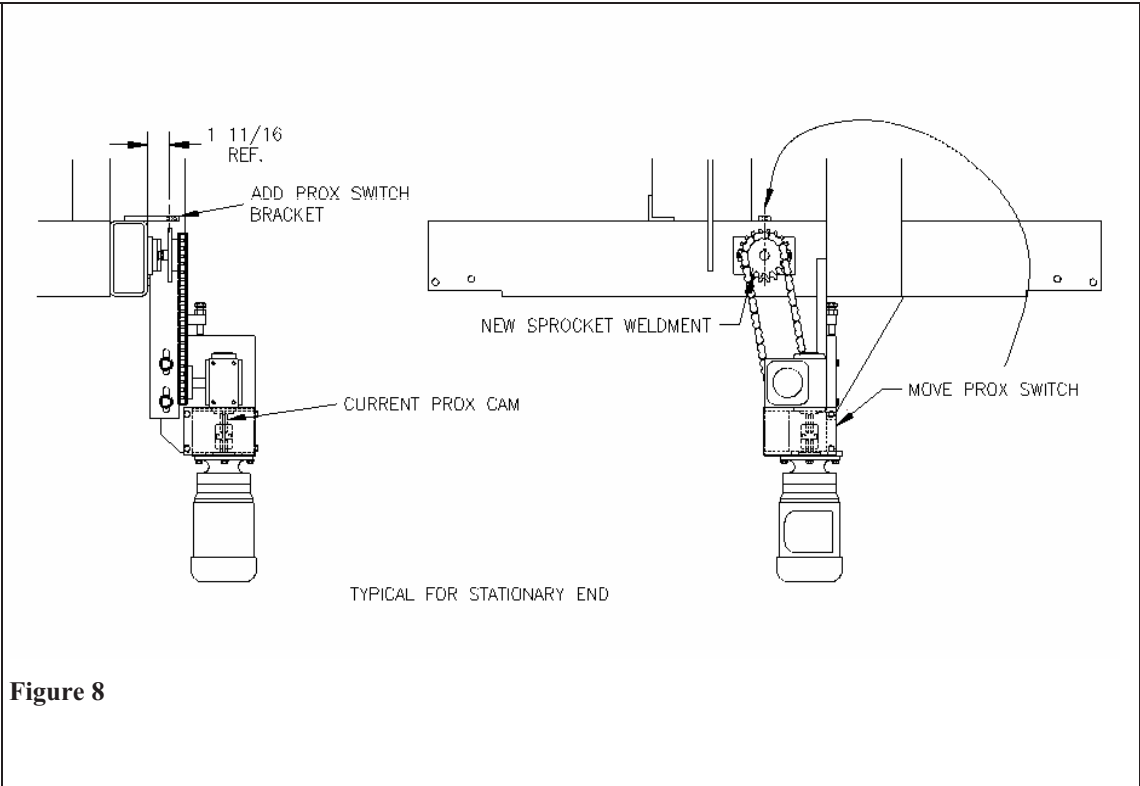

Figure 8

8. Please check all power cables to the saw motors.  
**IF NECESSARY** -- Clamp motor cables to quadrant bracket using cover bolt. See **Figure 9**

Parts needed:

Item	Quantity	MiTek Part No.
Clamps	6	794006
Spring	6	371998

9. On all saws with the larger touchscreen boxes, run a bead of silicone around the inside of the black touchscreen mounting plate.

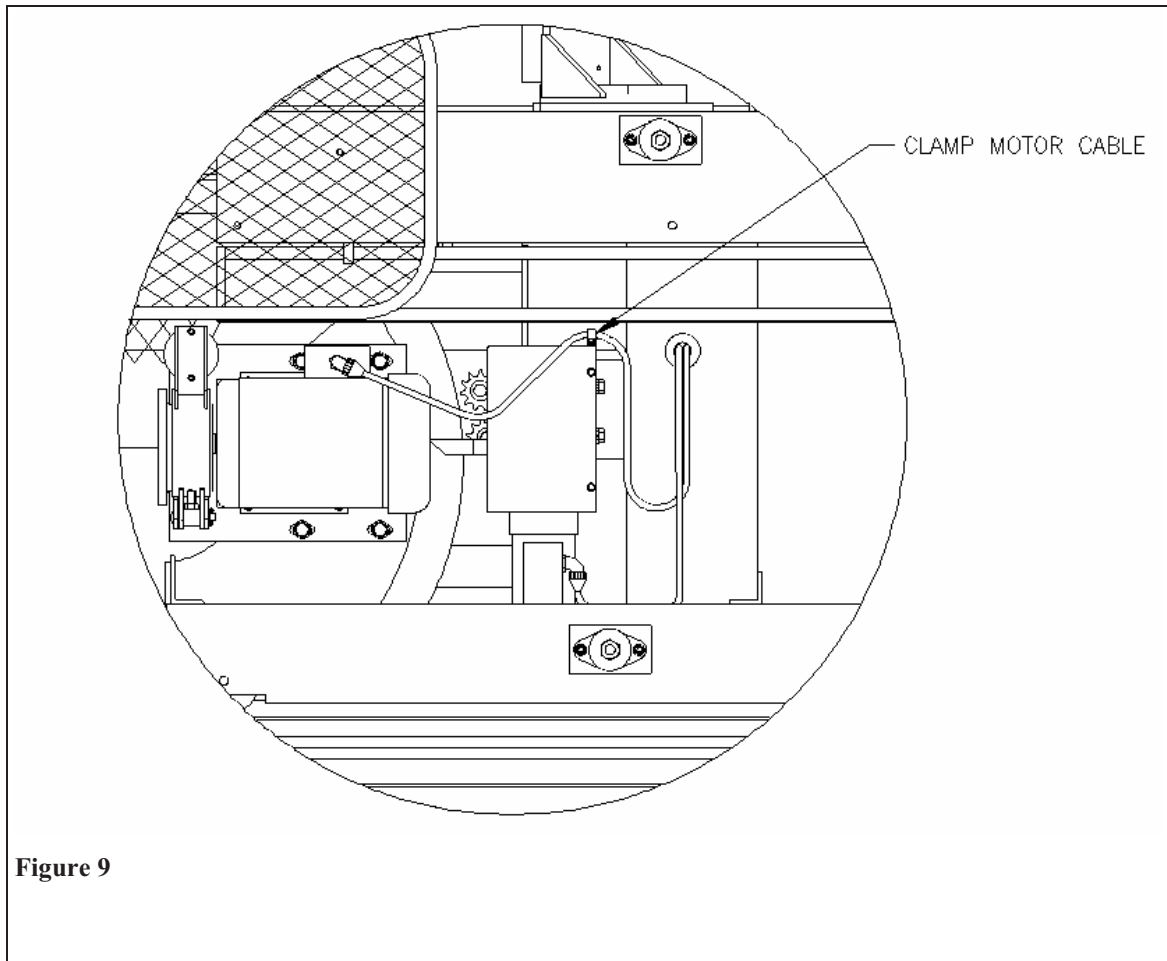



Saws that received this *SERVICE BULLETIN March 6, 1997*. All other saws were manufactured with these features in place.

- A.C. Houston (Minden, NV)
- Chamber's Truss
- Norway
- Heart Truss
- France (Gau)
- Australia
- MiTek U.K.
- Superior (Minnesota)
- Perfection Truss
- Australia (#2)
- MiTek U.K. (#2)
- Glaize & Brothers
- MiTek Germany

Contact MiTek Customer Service for the following drawings as needed:

**77124H**

**77126E**

**77198**

**77413A**

**77474E**

**77754L**

**77765M**

**77905M**

**77930K**

**77964B**

**79830I**